

**THROSSELL, WA,
AIRBORNE GEOPHYSICAL SURVEY, 1998,
OPERATIONS REPORT**

by

R. C. Brodie

**Australian Geological Survey Organisation
Record 1999/32**

DEPARTMENT OF INDUSTRY, SCIENCE & RESOURCES

Minister for Industry, Science and Resources: Senator the Hon. Nick Minchin
Parliamentary Secretary: The Hon. Warren Entsch, MP
Secretary: Russell Higgins

AUSTRALIAN GEOLOGICAL SURVEY ORGANISATION

Executive Director: Dr Neil Williams

© Commonwealth of Australia 1999

ISSN: 1039 – 0073

ISBN: 0 642 39792 9

Bibliographic reference: Brodie, R.C., 1999. Title – Throssell, WA, Airborne Geophysical Survey, 1998, Operations Report. Australian Geological Survey Organisation, Record 1999/32.

This work is copyright. Apart from any fair dealings for the purposes of study, research, criticism or review, as permitted under the *Copyright Act 1968*, no part may be reproduced by any process without written permission. Copyright is the responsibility of the Executive Director, Australian Geological Survey Organisation. Inquiries should be directed to the **Information Officer, Australian Geological Survey Organisation, GPO Box 378, Canberra City, ACT, 2601.**

AGSO has tried to make the information in this product as accurate as possible. However, AGSO does not guarantee that the information is totally accurate or complete. Therefore, you should not rely solely on this information when making a commercial decision.

CONTENTS

SUMMARY

1. SURVEY AREA AND PARAMETERS.....	1
(i) Area Description	1
(ii) Survey Parameters.....	1
2. LOGISTICS	1
(i) Operating Base and Dates of Flying.....	1
(ii) Survey Aircraft and Field Crew	2
3. SURVEY EQUIPMENT	2
(i) Major Equipment	2
(ii) Navigation	3
(iii) Magnetometer	4
(iv) Gamma-ray Spectrometer	4
(v) Altimeter	4
(vi) Barometer, Thermometer and Hygrometer	4
(vii) Base Station Magnetometer	5
(viii) Aircraft Data Acquisition.....	5
4. CALIBRATION	5
(i) Compensation for the Magnetic Field of the Aircraft	5
(ii) Gamma-ray Spectrometer Calibration	6
5. DATA PROCESSING.....	7
(i) Data Checking and Editing	7
(ii) Flight Path Recovery.....	7
(iii) Magnetic Data Processing.....	8
(iv) Gamma-ray Spectrometer Data Processing.....	9
(v) Digital Elevation Model Data Processing.....	13
(vi) Merging with Other Datasets	15
(vii) Final Products	16
6. REFERENCES	17

APPENDICES

APPENDICES

- A. Survey Area
- B. Flying Dates and Production Kilometres Flown
- C. Real Time Differential GPS
- D. Specifications of G822A Caesium Magnetometer
- E. Specifications of RMS Instruments Automatic Aeromagnetic Digital Compensator
- F. Specifications of GR820 Gamma-ray Spectrometer System
- G. Specifications of G823B Caesium Base Station Magnetometer
- H. Aircraft Data Acquisition System
- I. Compensation Results
- J. Gamma-ray Spectrometer Test Line Location
- K. The World Geodetic System 1984 Datum
- L. Corrections to Differential GPS Navigation Data
- M. Comparison of Third Order Gravity Station Elevations and Digital Elevation Model Derived from the Airborne Data
- N. Summary Specifications of Adjoining Survey
- O. Geophysical Maps
- P. AGSO Archive Data and Magnetic Tape Format for Airborne Geophysical Data

SUMMARY

The Australian Geological Survey Organisation (AGSO) flew an airborne geophysical survey of 39,698 line kilometres over all but the southwestern 1:100 000 map Sheet area of the Throssell 1:250 000 map Sheet area in the Eastern Goldfields of Western Australia. The survey was flown in two separate blocks known as the eastern block and western block. The eastern block covers the eastern two thirds of the Throssell 1:250 000 Sheet (Blaxland, Buldya, Yamarna and Lake Throssell 1:100 000 Sheets) area and the western block covers the northern half of the western third of the sheet (Strawbridge 1:100 000 Sheet).

The survey area covers part of the northeast margin of the Yilgarn Craton. Intermittent Archaean outcrop is restricted to the western half of the survey area. The cover includes Proterozoic Earraheedy Basin sediments in the north and Palaeozoic Officer Basin sediments in the east.

The eastern block was flown along north-south flight lines and the western block was flown along east-west flight lines. Both blocks were flown at 400 m line spacing at a nominal altitude of 60 m above ground level. AGSO flew the survey in May and June 1998

The total magnetic intensity, gamma-ray spectrometric and digital elevation model data which were collected during the survey, have been processed and merged with a separately acquired neighbouring dataset covering the south-western 1:100 000 map Sheet area (Jutson 1:100 000 Sheet). The entire dataset is available for purchase, in both digital (point located data and gridded) and map form, from AGSO. Additionally an interpretation of the data is available from AGSO.

1. SURVEY AREA AND PARAMETERS

(i) Area Description

The airborne geophysical survey covers all but the south-western 1:100 000 map Sheet area (Jutson 1:100 000 Sheet area) of the Throssell 1:250 000 map Sheet area in the Eastern Goldfields of Western Australia.

The survey was flown in two separate blocks, which throughout this report will be referred to as the eastern block and western block. The eastern block covers the eastern two thirds of the Throssell 1:250 000 Sheet (Blaxland, Buldya, Yamarna and Lake Throssell 1:100 000 Sheets) area and the western block covers the northern half of the western third of the sheet (Strawbridge 1:100 000 Sheet). The survey area is shown in Appendix A.

(ii) Survey Parameters

Altitude:	60 m above ground level
Flight line direction:	North – South (eastern block) East – West (western block)
Tie line direction:	East – West (eastern block) North – South (western block)
Survey line spacing	
Flight line spacing:	400 m
Tie line spacing:	4000 m
Survey distance flown	
Lines:	35,927 km
Ties:	3,771 km
Total distance:	39,698 km
Sampling interval	
Magnetics:	0.1 s (approx 7 m)
Gamma-ray spectrometrics:	1.0 s (approx 70 m)
GPS:	0.5 s (approx 35 m)
Altimeter:	1.0 s (approx 70 m)
Barometric pressure:	1.0 s (approx 700 m)
Temperature:	1.0 s (approx 700 m)
Humidity:	1.0 s (approx 700 m)

2. LOGISTICS

(i) Operating Base and Dates of Flying

(a) Operating Base

The survey continued on after completion of the Rason Airborne Geophysical Survey (Brodie, 1999), with the same crew and equipment. Aircraft and crew were based at Laverton, Western Australia for the duration of the survey from 9 May to 20 June 1998. The field crew continued to use the Laverton Shire Council Office at the Laverton Airport Terminal as a survey base.

(b) Flying Dates

The first calibration flight to compensate for the magnetic field of the aircraft, using an automatic aeromagnetic digital compensator was undertaken during the course of the above mentioned Rason survey on 1 and 2 May. Further compensations were undertaken on 22 May and 17 June after scheduled aircraft maintenance. Production flying commenced on 9 May and continued relatively uninterrupted until its completion on 20 June. Appendix B summarises flying days and production kilometres flown.

(ii) Survey Aircraft and Field Crew

(a) Aircraft

Aero Commander 500 S "Shrike", VH-BGE

(b) Field Crew

Party Leaders:	Ross Brodie	13 May to 21 June
	Ross Franklin	9 to 13 May
Technicians:	Tom Stokes	9 May to 21 June
Operators:	Craig Smith	9 May to 21 June
Pilots:	Capt. Neil McGreevey	9 May to 9 June
(Pearl Aviation)	Capt. Lee Geraghty	9 May to 21 June
	Capt. Shane Lawrey	3 June to 21 June

3. SURVEY EQUIPMENT

(i) Major Equipment

Magnetometer:	Geometrics G822A Caesium magnetometer
Compensator:	RMS Instruments Automatic Aeromagnetic Digital Compensator
Gamma-ray spectrometer:	Geometrics gamma-ray spectrometer consisting of a GR820 spectrum processor, and two DET1024 spectrometer crystal detectors (33.56 litres total)
Altimeter:	Collins ALT-50 radar altimeter
Barometer:	AGSO digital – Setra sensor
Thermometer/Hygrometer:	AGSO digital – RS combined humidity and temperature sensor
Navigation:	Ashtech XII "Ranger" GPS receivers Ashtech "Ranger" differential processing software Fugro OmniSTAR Plus real time differential GPS base station system
Video:	National colour video camera (WV CL 302E) National VCR (NV180), National LCD TV (TCL3A)
Acquisition hardware:	Axiom-Ax6150A industrial computer, 3.5 inch floppy disc drive, 504 Mb removable SCSI hard disc, IOMEGA SCSI zip drive and Planar VGA monitor
Acquisition software:	AGSO-developed QNX C language program

(ii) Navigation

(a) GPS Navigation System

Real time differential global positioning system (RT-DGPS) aircraft navigation was accomplished using Ashtech XII GPS receivers and a Fugro OmniSTAR Plus base station system.

The receiver in the aircraft received range data from the GPS satellites every half second and differential corrections every second and calculated the aircraft's current latitude and longitude coordinates in the World Geodetic System 1984 (WGS84). The range data were recorded internally in the GPS receiver every second.

A Fugro OmniSTAR Plus base station system was utilised for real time differential GPS corrections. This system uses differential corrections, supplied by Fugro Starfix Pty. Ltd., which are transmitted via an Optus satellite link.

The aircraft receiver applied the real time differential corrections in order to calculate the aircraft's differentially corrected latitude and longitude coordinates in the World Geodetic System 1984 (WGS84). Corrected position data were recorded on the aircraft acquisition system every half second and were also used to provide the pilot with aircraft guidance information on a LCD display. The RT-DGPS method employed is more fully described in Appendix C.

An Ashtech X11 base station GPS receiver, located at the survey base, internally recorded range data every second. The internally recorded range data were post processed using Ashtech "Ranger" differential processing software at the end of each flying day. The error in position of the post processed flight path data is approximately five metres or less.

The position of the base station GPS receiver was accurately determined by differential GPS surveying using both the "Mount Crawford (R167T reference marker)" and the "Laverton 15" trig sites, approximately 5 km and 3 km north of Laverton respectively, as a fixed reference points.

The determined base station GPS coordinates (WGS 84) were:

Longitude	:122° 25' 20.68037" E
Latitude	: 28° 36' 52.80573" S
Ellipsoidal height	: 449.8655 m

The horizontal positions of the geophysical data from the survey are reported with respect to the WGS84 Datum. Taking the accuracy of the navigation data into account, the WGS84 system can be considered to be the same as the Geocentric Datum of Australia (GDA) for the survey data. It is intended that the GDA will be fully adopted in Australia by the year 2000. For a given position in the survey area, the GDA coordinate will appear to lie approximately 205 m northeast of the corresponding Australian Geodetic Datum (AGD) coordinate. That is to convert from GDA to AGD, coordinates must be moved 142.5 m west and 147.4 m south.

(c) Video Flight Path Recording

The aircraft's flight path was recorded on a VHS video system consisting of a National colour video camera with a wide angle lens, a National VCR and a National LCD TV.

(iii) Magnetometer

A Geometrics G822A caesium magnetometer, with the sensor mounted in a boom attached to the rear of the aircraft, was used for the survey. The specifications of the magnetometer are summarised in Appendix D.

The recorded total magnetic field data were compensated in real time using an RMS Instruments automatic aeromagnetic digital compensator (AADC). The AADC compensates for the effects of aircraft motion and heading. The specifications of the AADC are summarised in Appendix E. Compensation procedures are described in Chapter 4.

The AADC applies a low pass filter to the total magnetic field intensity data using a second order 0.9 Hz recursive Butterworth filter. The uncompensated, the filtered compensated total magnetic field intensity data and the X, Y, Z components and calculated total field of the fluxgate sensor were recorded on the aircraft acquisition system.

(iv) Gamma-ray Spectrometer

An Exploranium gamma-ray spectrometer, incorporating two DET1024 crystal detectors with a total volume of 33.56 litres, was used. An Exploranium GR820 spectrum processor controlled the crystal gains. Appendix F summarises the specifications of the gamma-ray spectrometer components.

Two hundred and fifty six channels of data, between 0.0 MeV and 3.00 MeV, were recorded every second. Additionally, five windows of data were recorded once a second using the following window limits:

Total count	0.410 – 3.00 MeV
Potassium	1.370 – 1.570 MeV
Uranium	1.660 – 1.860 MeV
Thorium	2.410 – 2.810 MeV
Cosmic	3.00 MeV and above

Total count, potassium, uranium and thorium window counts were used for data checking during acquisition and the cosmic counts were used for cosmic background estimation and later data processing.

(v) Altimeter

A Collins ALT-50 radar altimeter was used to measure ground clearance. The radar altimeter display indicates ground clearance from 0-2000 feet. The manufacturer's specifications claim $\pm 2\%$ accuracy for the ALT-50 system.

(vi) Barometer, Thermometer and Hygrometer

Atmospheric pressure, temperature and humidity were measured using a digital barometer (Setra sensor) and combined digital thermometer/hygrometer (RS sensor). The analogue output sensors were integrated into the data acquisition system via an analogue to digital converter. The sensors were factory calibrated and no AGSO calibrations were performed.

(vii) Base Station Magnetometer

Daily variations of the Earth's magnetic field were monitored using a Geometrics G823B caesium base station magnetometer. The specifications of the base station magnetometer are given in Appendix G. The base station was set up in an area of shallow magnetic gradient, away from cultural influences and within telemetry range of the survey base in the terminal building of the Laverton airport.

Data from the base station were telemetered back to the survey base for display and recording on a Toshiba Pentium 110 CS notebook computer. The telemetry system used Proxim Proxlink MSP500 modems. The software program, "DIURNAL", developed in-house by AGSO, was used to display and log diurnal data. Base station diurnal data were recorded at an interval of 0.1 seconds for every production and compensation flight.

(viii) Aircraft Data Acquisition

The aircraft acquisition program and system were run using an Axiom-Ax6150A industrial 486 computer with data recorded via an IOMEGA SCSI zip drive onto 100 Megabyte zip discs.

The acquisition program, which was written in the C language and developed in-house at AGSO, was run under the QNX operating system. See Appendix H for a schematic diagram of the aircraft's acquisition system.

4. CALIBRATION

(i) Compensation for the Magnetic Field of the Aircraft

Compensation flights were flown in an area of low magnetic gradient prior to the start of the survey and after each aircraft service. The flights were flown at an altitude of 2800 m above sea level, immediately to the south of the Rason 1:250 000 map Sheet area, approximately 190 km east-southeast of Laverton over an area between 124° 00' to 124° 15' E and 29° 15' to 29° 30' S.

The compensation comprises a series of rolls ($\pm 10^\circ$), pitches ($\pm 5^\circ$) and yaws ($\pm 5^\circ$) in the four cardinal headings to enable the AADC to calculate correction coefficients needed to remove aircraft manoeuvre noise. Each manoeuvre component was of 30 s duration.

The compensation manoeuvres were repeated after calculation of the coefficients to check the compensation quality. Prior to compensation the peak-to-peak manoeuvre noise was generally 1 nT. Peak-to-peak noise during repeat manoeuvres after the compensation was 0.18 nT or less. On normal survey flights, noise levels from all sources were generally less than 0.1 nT peak-to-peak.

The AADC calculates basic statistics, which reflect the degree of merit of the compensation. These include the standard deviation of the recorded data without corrections applied, the standard deviation with the corrections applied, the improvement ratio (the ratio of the standard deviation of the recorded data without and with the corrections applied) and the vector norm (the degree of difficulty in calculating the corrections). Appendix I lists these statistics, the dates the compensations were performed and the period over which each compensation was used.

(ii) Gamma-ray Spectrometer Calibration

The GR820 spectrum processor uses a sophisticated automatic control method to maintain crystal alignment while stabilising on naturally occurring isotopes (typically potassium or thorium). During operation, the system continuously monitors and accumulates separate spectra for each crystal detector. When the confidence level for the selected stabilisation peak (thorium) is exceeded, the peak channel of this isotope is computed, compared to the correct peak location, and the gain is then corrected. The gain for each crystal was corrected at least every 30 minutes.

Crystal alignment, resolution and sensitivity checks were performed at the start of each day of production flying. Adjustments were made to ensure the spectrometer stabilised on the thorium 2.62 MeV photopeak at channel 206.

As verification that the system sensitivity remained constant, thorium source tests were performed at the start and end of each day of production flying. The first step in the procedure involved placing the same small thorium sources in a jig located approximately 50 cm below each of the spectrometer detectors so that the sources maintained a constant orientation and position with respect to the detectors. A spectrum was then accumulated for long enough to ensure that the gaussian error in the thorium window counts was less than 0.75% (approximately 70 seconds). The thorium sources were then removed and a background accumulation was similarly performed (approximately 130 seconds). The livetime corrected and energy calibrated background spectrum was subtracted from the "source plus background" spectrum (corrected in the same manner) to yield the spectrum for the small thorium sources alone. The counts in the thorium window of the background corrected source spectrum was then compared to the corresponding value of (143.1 cps) that had been obtained during the previous pad calibrations in March 1998. Over the duration of the survey the value ranged between 139.8 cps and 149.7 cps and averaged 144.8 cps. The maximum, minimum and average percentage deviation from the nominal value of 143.1 was 4.6%, -2.3% and 1.22% respectively.

The resolution of the gamma-ray spectrometer system was measured during the system sensitivity check using the full width at half maximum method (IAEA, 1991). The resolution of the thorium peak was 5.10 % at the beginning of the survey and did not vary by more than 1% over the duration of the survey.

Gamma-ray spectrometric test lines were flown at the beginning and end of each production flight. Due to operational efficiencies separate test lines were used for the eastern and western blocks of the survey. The test line for the eastern block was located 115 km northeast of Laverton and the test line for the western block was located 125 km north-northeast of Laverton. The 7 km long test lines were flown at survey altitude using real time differential GPS navigation and lasted 100 s. The location of the test lines are shown in Appendix J.

After each flight the gamma-ray data were processed and statistics were calculated from processed data recorded between fixed reference points along the test lines. For each of the two test lines, these statistics were recorded in spreadsheet form and compared to the preceding flights along that test line in order to detect any irregularities. In particular, the percentage difference between the average background corrected thorium channel counts for each test line and the running average of all previously flown test lines was analysed. This value did not exceed 7.6% (standard deviation of 2.7%) for the eastern

block test line or 9.7% (standard deviation of 5.1%) for the western block test line, well inside a 15% variation, which is considered acceptable.

5. DATA PROCESSING

Flight path recovery, data checking and editing, diurnal variation and preliminary IGRF corrections applied to the magnetic data, gridding and imaging were performed at the survey base using the INTREPID data processing system. Final magnetic, gamma-ray spectrometric and digital elevation model data processing were carried out in Canberra using the INTREPID data processing system.

(i) Data Checking and Editing

Data recorded on the aircraft acquisition zip drive were transferred on a flight by flight basis from the zip disc to a Graphics Computer Systems Scorpion 10 Workstation (SUN Clone). All data transferred to this workstation was edited for missing values, noise, spikes or steps using INTREPID software. All the recorded data were displayed for each survey line and any errors were interactively corrected. Anomalies arising from cultural influences, such as sheds, houses and fences, were usually not edited out. They were edited out if they caused severe noise or caused the magnetometer to loose lock.

(ii) Flight Path Recovery

The range data, which were recorded internally every second on both GPS receivers, were post-processed daily in the field using "Ranger" – an Ashtech proprietary program. "Ranger" calculates the corrected flight path (longitude, latitude and height) relative to the World Geodetic System 1984 (WGS84) reference ellipsoid.

At the end of each flying day the corrected longitude and latitude data calculated at one second intervals by "Ranger" were used to correct the GPS data which were recorded every half second on the aircraft acquisition system. As well as the standard "Ranger" corrections, other acquisition system specific corrections were applied. Position data were retained in the WGS84 coordinate system. The WGS84 is defined in Appendix K. Taking the accuracy of the navigation data into account, the WGS84 system can be considered to be the same as the Geocentric Datum of Australia (GDA) for the survey data. For a given position in the survey area, the GDA coordinate will appear to lie approximately 205 m northeast of the corresponding Australian Geodetic Datum (AGD) coordinate. That is to convert from GDA to AGD, coordinates must be moved 142.5 m West and 147.4 m South.

The full post-processing correction procedure applied to the position data is described in Appendix L and is outlined below;

- (a) "Ranger" corrections.
- (b) Infilling of "Ranger" data.
- (c) Infilling of final navigation data.
- (d) Low pass filter.
- (e) Reference navigation data to position of magnetometer sensor.

The fully corrected flight path was plotted each day to check the position of survey lines and their spacing. Navigation reflies were determined by the following criteria:

Line Spacing	Across Track Deviation	Distance along line
400 m	30 m	greater than 3 km

Where both the across track deviation and along line distance were exceeded that portion of the survey line was reflown.

(iii) Magnetic Data Processing

Compensated checked and edited magnetic data were read into an INTREPID database which included the navigation data. Diurnal variation corrections were applied. The 0.1 s data recorded from the G823B base station magnetometer were used for the diurnal variation correction. These 0.1 s data were low pass filtered prior to the correction being applied. The filter used removed high frequency variations with periods less than 20 seconds.

The IGRF 1995 geomagnetic reference field, updated to 10 May 1998 and for an altitude of 465 m above sea level (estimated to be the mean survey altitude) was then subtracted from the data. The IGRF was calculated from the coefficients defined by the International Association of Geomagnetism and Aeronomy, Barton (1997). All magnetic values were adjusted by a constant so that the average residual magnetic field value was approximately 5000 nT.

The data were levelled using standard tie line levelling procedures. Luyendyk (1997) describes the procedure involved in the tie line levelling method in more detail. Tie line levelling was carried out separately for the eastern and western blocks. The steps involved in the tie line levelling of each block were as follows;

Eastern block:

- (a) Tie line 370 was chosen as the reference tie.
- (b) All other ties were levelled to tie line 370 using degree three piecewise polynomial adjustments.
- (c) Lines were adjusted on a flight by flight basis to minimise the differences at line/tie crossover points. Degree three piecewise polynomial adjustments were used.
- (d) Finally the lines were individually adjusted to minimise crossover differences, using degree two piecewise polynomial adjustments.

Western block:

- (a) Nine of the tie line levelled north-south flight lines that were part of the eastern block (3000, 3005, 3010, 3015, 3020, 3030, 3040, 3050 and 3060) but crossed the east-west flight lines in the western block were used as ties for the levelling procedure in the western block. Flight line 3020 was chosen as the reference tie.
- (b) All other ties were levelled to line 3020 using degree three piecewise polynomial adjustments. Any adjustments made to the nine flight lines from the eastern block in this step were not actually applied to the data – the adjustments were simply used for the levelling procedure.

- (c) Lines were adjusted on a flight by flight basis to minimise the differences at line/tie crossover points. Degree two piecewise polynomial adjustments were used.
- (d) Finally the lines were individually adjusted to minimise crossover differences, using degree one piecewise polynomial adjustments.

Magnetic data did not require micro-levelling. The tie line levelled data were gridded using the minimum curvature technique described by Briggs (1974), employing a 80 metre (3.0") grid cell size.

(iv) Gamma-ray Spectrometer Data Processing.

A combination of full-spectrum and 3-channel processing methods were used to correct the gamma-ray spectrometric data. The raw spectra were first smoothed using the Noise Adjusted Singular Value Decomposition (NASVD) spectral smoothing technique described by Hovgaard and Grasty (1997), applied to spectral clusters according to the methodology described by Minty and McFadden (1998). This method transforms observed spectra into orthogonal spectral components. The higher-order components represent the signal in the observed spectra and the lower-order components represent uncorrelated noise. Noise is removed from the observed spectra by rejecting noise components and reconstructing smooth spectra from the higher-order components. For this survey, 8 higher-order components were used to reconstruct the smooth spectra. The smoothed spectra were livetime corrected, energy calibrated and background corrected. The spectra were then summed over the conventional 4-channel windows (IAEA, 1991), for subsequent stripping and height correction as described below.

The energy calibration was performed by using the positions of prominent photopeaks in the accumulated line spectrum (the sum of all individual spectra for the line) to obtain an estimate of the base energy (energy at channel one in keV) and the gain (channel width in keV). These parameters were then used to correct each spectrum in the line by resampling each channel over its correct energy range.

The three components of background were determined as follows.

(a) Aircraft and Cosmic Background

Aircraft and cosmic spectra for the AGSO aircraft were determined from high altitude calibration flights using the procedure described by Minty and Richardson (1989).

(b) Atmospheric Radon Background

A full spectrum method (Minty, 1998) was used to remove radon background. The method is based on the assumption that the observed spectrum (after correcting for aircraft and cosmic background) is the linear sum of the spectra due to K, U, and Th in the ground and atmospheric radon. Since the shapes of these spectra can be determined through suitable calibrations, the atmospheric radon contribution to the observed spectrum can be estimated.

The energy-calibrated and background-corrected spectra were then summed over the conventional 4-channel windows recommended by the IAEA (IAEA, 1991). Stripping corrections (channel interaction corrections) to correct for Compton scattering were then applied to the K, U, and Th window count rates. Stripping ratios for the AGSO system were determined using the procedure recommended by the International Atomic Energy Agency (IAEA, 1991). The corrections were applied as follows:

$$\begin{aligned}N_{\text{TH(corrected)}} &= N_{\text{TH}} \\N_{\text{U(corrected)}} &= N_{\text{U}} - A \times N_{\text{TH(corrected)}} \\N_{\text{K(corrected)}} &= N_{\text{K}} - B \times N_{\text{TH}} - C \times N_{\text{U(corrected)}}\end{aligned}$$

where;

$$\begin{aligned}N_{\text{TH}} &= \text{Counts in the thorium channel} \\N_{\text{U}} &= \text{Counts in the uranium channel} \\N_{\text{K}} &= \text{Counts in the potassium channel} \\A &= 0.3098 + 0.00049 \times \text{height} \\B &= 0.3830 + 0.00065 \times \text{height} \\C &= 0.8381 + 0.00069 \times \text{height}\end{aligned}$$

The data were then corrected for height attenuation and reduced to a nominal flying height of 60 m. Where the aircraft attained a height of 250 m or higher above the ground gamma-ray spectrometric data have been set to undefined. Height attenuation corrections were made using the following formula:

$$N_{\text{corrected}} = N_{\text{uncorrected}} e^{-u(H-h)}$$

where

$$\begin{aligned}N_{\text{corrected}} &= \text{Corrected counts} \\N_{\text{uncorrected}} &= \text{Uncorrected counts} \\H &= \text{Nominal flying height} \\h &= \text{Measured flying height} \\u &= \text{Attenuation coefficient}\end{aligned}$$

Attenuation coefficients for each channel are given below:

$$\begin{aligned}U_{\text{total count}} &= 0.00785 \\U_{\text{potassium}} &= 0.00943 \\U_{\text{uranium}} &= 0.01150 \\U_{\text{thorium}} &= 0.00747\end{aligned}$$

The corrected window count rates were then converted to ground concentrations of K, U and Th using the expression:

$$C = \frac{N}{S}$$

where;

$$\begin{aligned}C &= \text{Concentration of the radioelement (K\%, U ppm or Th ppm);} \\S &= \text{Broad source sensitivity for the elemental count rate; and} \\N &= \text{Fully processed elemental count rate (cps).}\end{aligned}$$

The broad source sensitivities were obtained from flights over the Lake Hume calibration range. The following sensitivities were used:

Potassium:	136.06 cps/%K
Uranium:	10.05 cps/ppm eU
Thorium:	6.79 cps/ppm eTh.

The total count was converted to the equivalent air-absorbed dose rate at ground level using the expression:

$$D = \frac{N}{F}$$

where;

D	=	Air absorbed dose rate (nanoGrays per hour, (nGh ⁻¹));
F	=	The conversion factor determined experimentally from flights over a calibration range (35.06 cps/nGh ⁻¹); and
N	=	Fully processed total count rate (cps).

Before any further processing of the gamma-ray spectrometric, data the associated position data were corrected for a parallax error of -9.03 m (ie. shifted toward the front of the aircraft by 9.03 m) to account for the difference between the position of the spectrometer crystals and the position data reference point (at the magnetometer sensor).

The thorium data did not require tie line levelling. The total count, potassium and uranium data were levelled in much the same way as the magnetic data. However prior to sampling the crossover points, a 5 point convolution filter with a cut-off wavelength of 350 m was passed over the data. Note that these filtered data were only used for the crossover analysis and the final point located data have not been filtered.

Tie line levelling was carried out separately for the eastern and western blocks. The steps involved in the tie line levelling of each block were as follows;

Eastern block (total count, potassium and uranium only):

- (a) Tie line 370 was chosen as a reference tie for total count and potassium. Tie 510 was chosen for uranium.
- (b) All other ties were levelled to the reference tie line using degree three piecewise polynomial adjustments for total count and degree zero for potassium and uranium.
- (c) Lines were adjusted on a flight by flight basis using degree three piecewise polynomial adjustments for total count and degree zero for potassium and uranium, to minimise the differences at line/tie crossover points.
- (d) The lines were then individually adjusted to minimise crossover differences using degree one piecewise polynomial adjustments for total count and degree zero for potassium and uranium,

Western block (uranium only):

- (a) Nine of the tie line levelled north-south flight lines that were part of the eastern block (3000, 3005, 3010, 3015, 3020, 3030, 3040, 3050 and 3060) but crossed the

east-west flight lines in the western block were used as ties for the levelling procedure in the western block. Flight line 3020 was chosen as the reference tie.

- (b) All other ties were levelled to line 3020 using degree three piecewise polynomial adjustments.
- (c) Lines were adjusted on a flight by flight basis using degree one piecewise polynomial adjustments, to minimise the differences at line/tie crossover points.
- (d) Lines were not individually adjusted to minimise crossover differences.

Gamma-ray spectrometric data were micro-levelled using the technique described by Minty (1991). Filter characteristics are described below;

Eastern block:

- (a) Low pass filter in the flight line direction with a cut-off wavelength of 5000 m for total count, potassium and uranium and 15000 m for thorium.
- (b) High pass filter in the tie line direction with a cut-off wavelength of 800 m.
- (c) Correction strings were low pass filtered with a cut-off wavelength of 1000 m before being applied to the line data and were constrained to lie within the following ranges;
 - $\pm 5 \text{ nGh}^{-1}$ for total count (95% of adjustments were less than $\pm 1.66 \text{ nGh}^{-1}$)
 - $\pm 0.1 \%$ for potassium (95% of adjustments were less than $\pm 0.026 \%$)
 - $\pm 1.0 \text{ ppm}$ for uranium (95% of adjustments were less than $\pm 0.18 \text{ ppm}$)
 - $\pm 2.0 \text{ ppm}$ for thorium (95% of adjustments were less than $\pm 0.65 \text{ ppm}$)

In the eastern block, potassium and uranium required a second pass of micro levelling with the following filter characteristics;

- (a) Low pass filter in the flight line direction with a cut-off wavelength of 10000 m.
- (b) High pass filter in the tie line direction with a cut-off wavelength of 1600 m.
- (c) Correction strings were low pass filtered with a cut-off wavelength of 1000 m before being applied to the line data and were constrained to lie within the following ranges;
 - $\pm 0.05 \%$ for potassium (95% of adjustments were less than $\pm 0.014 \%$)
 - $\pm 1.0 \text{ ppm}$ for uranium (95% of adjustments were less than $\pm 0.14 \text{ ppm}$)

Western block:

- (a) Low pass filter in the flight line direction with a cut-off wavelength of 10000 m.
- (b) High pass filter in the tie line direction with a cut-off wavelength of 1600 m.
- (c) Correction strings were low pass filtered with a cut-off wavelength of 1000 m before being applied to the line data and were constrained to lie within the following ranges;
 - $\pm 5 \text{ nGh}^{-1}$ for total count (95% of adjustments were less than $\pm 2.13 \text{ nGh}^{-1}$)
 - $\pm 0.1 \%$ for potassium (95% of adjustments were less than $\pm 0.023 \%$)

- ± 1.0 ppm for uranium (95% of adjustments were less than ± 0.265 ppm)
- ± 2.0 ppm for thorium (95% of adjustments were less than ± 0.37 ppm)

All channels were gridded to a 80 metre (3.0") cell size using Brigg's minimum curvature technique.

(v) Digital Elevation Model Data Processing.

As described in Chapter 5 – Section (ii), range data recorded internally every second by both GPS receivers were post-processed on a daily basis using "Ranger" - an Ashtech proprietary program. "Ranger" calculates the position of aircraft GPS receiver's antenna, including longitude, latitude and height relative to the WGS84 reference ellipsoid for each set of range data (every second).

As in the case of the longitude and latitude data, the following acquisition system specific corrections, which are described in Appendix L, are applied to the height data:

- (a) "Ranger" corrections.
- (b) Barometric infill of height gaps.

The corrected height data, which are relative to the WGS84 reference ellipsoid, are then linearly interpolated to half-second samples (35 m) and are merged with the longitude and latitude data.

A radar altimeter provided the aircraft's ground clearance, the altimeter data being sampled every one second.

The raw ground elevation data were then calculated as the difference between the height of the aircraft above the ellipsoid and the height of the aircraft above the ground. These raw elevation data, calculated every half second (35 m along the ground) are relative to the WGS84 reference ellipsoid - the ellipsoid being a horizontal datum.

Before any further processing of the digital elevation model data the associated position data were corrected for a parallax error of -11.4 m (ie. shifted toward the front of the aircraft by 11.4 m) to account for the difference between the position of the GPS and radar altimeter antennae and the position data reference point (at the magnetometer sensor).

Elevation data were tie line levelled separately in the eastern and western blocks, in much the same way as the magnetic data. The steps involved in tie line levelling were as follows;

Eastern block:

- (a) Tie line 370 was chosen as a reference tie.
- (b) All other ties were levelled to the reference tie line using degree three piecewise polynomial adjustments.
- (c) Lines were adjusted on a flight by flight basis using degree three piecewise polynomial adjustments to minimise the differences at line/tie crossover points.

- (d) The lines were then individually adjusted to minimise crossover differences using degree one piecewise polynomial adjustments.

Western block:

- (e) Nine of the tie line levelled north-south flight lines that were part of the eastern block (3000, 3005, 3010, 3015, 3020, 3030, 3040, 3050 and 3060) but crossed the east-west flight lines in the western block were used as ties for the levelling procedure in the western block. Flight line 3020 was chosen as the reference tie.
- (f) All other ties were levelled to line 3020 using degree three piecewise polynomial adjustments. Any adjustments made to the nine flight lines from the eastern block in this step were not actually applied to the data – the adjustments were simply used for the levelling procedure.
- (g) Lines were adjusted on a flight by flight basis to minimise the differences at line/tie crossover points. Degree three piecewise polynomial adjustments were used.
- (h) Lines were not individually adjusted to minimise crossover differences.

Elevation data were then micro-levelled using the technique described by Minty (1991). Filter characteristics are described below;

Eastern block:

- (a) Low pass filter in the flight line direction with a cut-off wavelength of 10000 m.
- (b) High pass filter in the tie line direction with a cut-off wavelength of 800 m.
- (c) Correction strings were low pass filtered with a cut-off wavelength of 1000 m before being applied to the line data and were constrained to lie within the range ± 5 m (95% of the corrections fell in the range ± 1.02 m and 90% fell in the range ± 0.82 m).

A second pass of micro-levelling was applied to the eastern block with the following filter characteristics;

- (a) Low pass filter in the flight line direction with a cut-off wavelength of 5000 m.
- (b) High pass filter in the tie line direction with a cut-off wavelength of 800 m.
- (c) Correction strings were low pass filtered with a cut-off wavelength of 1000 m before being applied to the line data and were constrained to lie within the range ± 3 m (95% of the corrections fell in the range ± 0.40 m and 90% fell in the range ± 0.26 m).

Western block:

- (d) Low pass filter in the flight line direction with a cut-off wavelength of 5000 m.
- (e) High pass filter in the tie line direction with a cut-off wavelength of 800 m.
- (f) Correction strings were low pass filtered with a cut-off wavelength of 1000 m before being applied to the line data and were constrained to lie within the range ± 3 m (95% of the corrections fell in the range ± 1.25 m and 90% fell in the range ± 1.00 m).

The next step was to convert the heights relative to the WGS84 ellipsoid to heights relative to the geoid. The geoid, which is defined as "the equipotential surface of the

gravity field which best approximates mean sea level", is usually chosen as the datum to which heights plotted on maps are referred. The height of the geoid above the WGS84 ellipsoid is called the geoid - ellipsoid separation or N value.

Geoid - ellipsoid separation information for the survey area were supplied by the Australian Surveying and Land Information Group (AUSLIG) in July 1998. The set of N values were supplied as a 10 minute of arc (approximately 18 km) grid. AUSLIG also provides a program "DINTER" which uses bilinear interpolation to calculate N values on a one minute of arc (approximately 1600 metre) grid.

These values were then imported into an INTREPID database and gridded using the INTREPID software package to a cell size of 15 seconds of arc (approximately 400 m). This grid of N values was used to calculate correction strings to be subtracted from the elevation data. The correction strings were low pass filtered with a cut-off wavelength of 500 m before being applied to the point-located elevation data.

The elevation data were then corrected to account for the vertical separation between the antenna of the aircraft's GPS receiver, on the roof of the aircraft, and radar altimeter on the belly of the aircraft. This antenna separation distance of 1.675 m was subtracted from the elevation data.

The accuracy of the position located height data is expected to be better than ± 2 metres. Relative precision from point to point along a flight line is expected to be better than ± 1 metre.

A comparison was made between third order gravity station heights, measured by barometric methods, and the elevation data. There were 97 gravity stations within 50 m of the point on the ground directly below airborne sample points. For these 97 stations the elevation data were on average 1.96 m larger than the gravity station heights. The standard deviation of the differences between the elevation data and gravity station heights was 4.96 m. Appendix M details the comparison between the 97 gravity stations and their corresponding nearest sample point in the digital elevation model derived from the airborne data.

The fully corrected elevation data were gridded using ANUDEM46 (Hutchinson, 1988, 1989) employing a 80 metre (3.0") grid cell size.

(vi) Merging with Other Datasets

Final processed magnetic and gamma-ray spectrometric data from an adjoining survey flown by World Geoscience Corporation, were levelled, merged and archived with the final processed magnetic and gamma-ray spectrometric data from this survey.

The adjoining survey was a World Geoscience Corporation multi-client survey flown between 15 October 1989 and 13 January 1990 at 200 metre line spacing utilising SYLEDIS radio navigation at a nominal terrain clearance of 60 metres. The survey is filed under Project 660 in AGSO's National Airborne Geophysical Survey Database and its specifications are summarised in Appendix N.

Digital elevation model data are not available for the adjoining World Geoscience Corporation survey.

(vii) Final Products

(a) Standard AGSO geophysical maps

An AGSO standard set of geophysical maps have been produced at scales of 1:250 000 and 1:100 000 for the Throssell 1:250 000 map sheet. Flight path and contour maps were produced using the INTREPID software. The standard set of maps produced are shown in Appendix O.

(b) Digital data

Final processed point-located data were archived in the standard AGSO ARGUS (ASCII) format. See Appendix P for details of the AGSO ARGUS format. Gridded data were archived in ERMapper binary grid format with ASCII (.ers) header files. Data were archived on Exabyte (8mm) magnetic tape cartridges and compact discs.

(c) Pixel image maps

Additional to the standard AGSO geophysical maps listed in Appendix O pixel image maps have been compiled using the method described by Milligan and others (1992). The following pixel image maps have been released at 1:250 000 scale for the Throssell 1:250 000 map sheet;

- (i) Colour total magnetic intensity reduced to the pole with gradient enhancement of the first vertical derivative.
- (ii) Greyscale vertical derivative of total magnetic intensity reduced to the pole.

Digital versions of the pixel image data are available on CR-ROM in BIL format suitable for import into and use in many standard geographic information system (GIS) applications.

(d) Interpretation

AGSO has interpreted the geophysical data acquired from the survey. The results of the interpretation will be available as a hardcopy "Interpreted Geology Map" at 1:250 000 scale for the Throssell 1:250 000 map sheet. The results will also be available in digital form on CD-ROM in a format suitable for import into and use in many standard geographic information system (GIS) applications.

6. REFERENCES

- Barton, C.E., 1997 - International Geomagnetic Reference Field: The Seventh Generation. *Journal of Geomagnetism and Geoelectricity*, **49**, 123-148.
- Briggs, I.C., 1974 - Machine contouring using minimum-curvature. *Geophysics*, **39**, 39-48.
- Brodie, R.C. (1999). Rason, WA, Airborne Geophysical Survey, 1998, Operations Report. *Australian Geological Survey Organisation*, **Record 1999/31**.
- Grasty, R. L., 1975 - Uranium measurements by airborne gamma-ray spectrometry. *Geophysics*, **40**, 503-519.
- Hovgaard, J., and Grasty, R.L., 1997 - Reducing statistical noise in airborne gamma-ray data through spectral component analysis. In "*Proceedings of Exploration 97: Fourth Decennial Conference on Mineral Exploration*" edited by A., G., Gubins, 1997, 753-764.
- Hutchinson, M.F., 1988 - Calculation of hydrologically sound digital elevation models. Third International Symposium on Spatial Data Handling, Sydney. *International Geographical Union, Columbus*, 117-133.
- Hutchinson, M.F., 1989. - A new procedure for gridding elevation and stream line data with automatic removal of spurious pits. *Journal of Hydrology*, **106**, 211-232.
- International Atomic Energy Agency, 1991 - Airborne Gamma Ray Spectrometer Surveying. *International Atomic Energy Agency Technical Reports Series Number 323*, IAEA Vienna.
- Luyendyk, A.P.J., 1997 - Processing of airborne magnetic data. *AGSO Journal of Geology and Geophysics*, **17** (2), 31-38.
- Milligan, P. R., Morse, M. P., and Rajagopalan, S., 1992 - Pixel map preparation using the HSV colour model. *Exploration Geophysics*, **23**, 219-224.
- Minty, B. R. S., 1991 - Simple micro-levelling for aeromagnetic data. *Exploration Geophysics*, **22**, 591-592.
- Minty, B. R. S., 1998 - Multichannel models for the estimation of radon background in airborne gamma-ray spectrometry. *Geophysics*, **63** (6), 1986-1996.
- Minty, B. R. S., and McFadden P., 1998 - Improved NASVD smoothing of airborne gamma-ray spectra. *Exploration Geophysics*, **29**, 516-523.
- Minty, B. R. S., Morse, M. P., and Richardson, L. M., 1990 - Portable calibration sources for airborne gamma-ray spectrometers. *Exploration Geophysics*, **21**, 187-195.
- Minty, B. R. S., and Richardson, L. M., 1989 - Calibration of the BMR airborne gamma-ray spectrometer upward-looking detector, February 1989. *Bureau of Mineral Resources, Australia, Record 1989/8*.

Appendix A-1

Survey Area

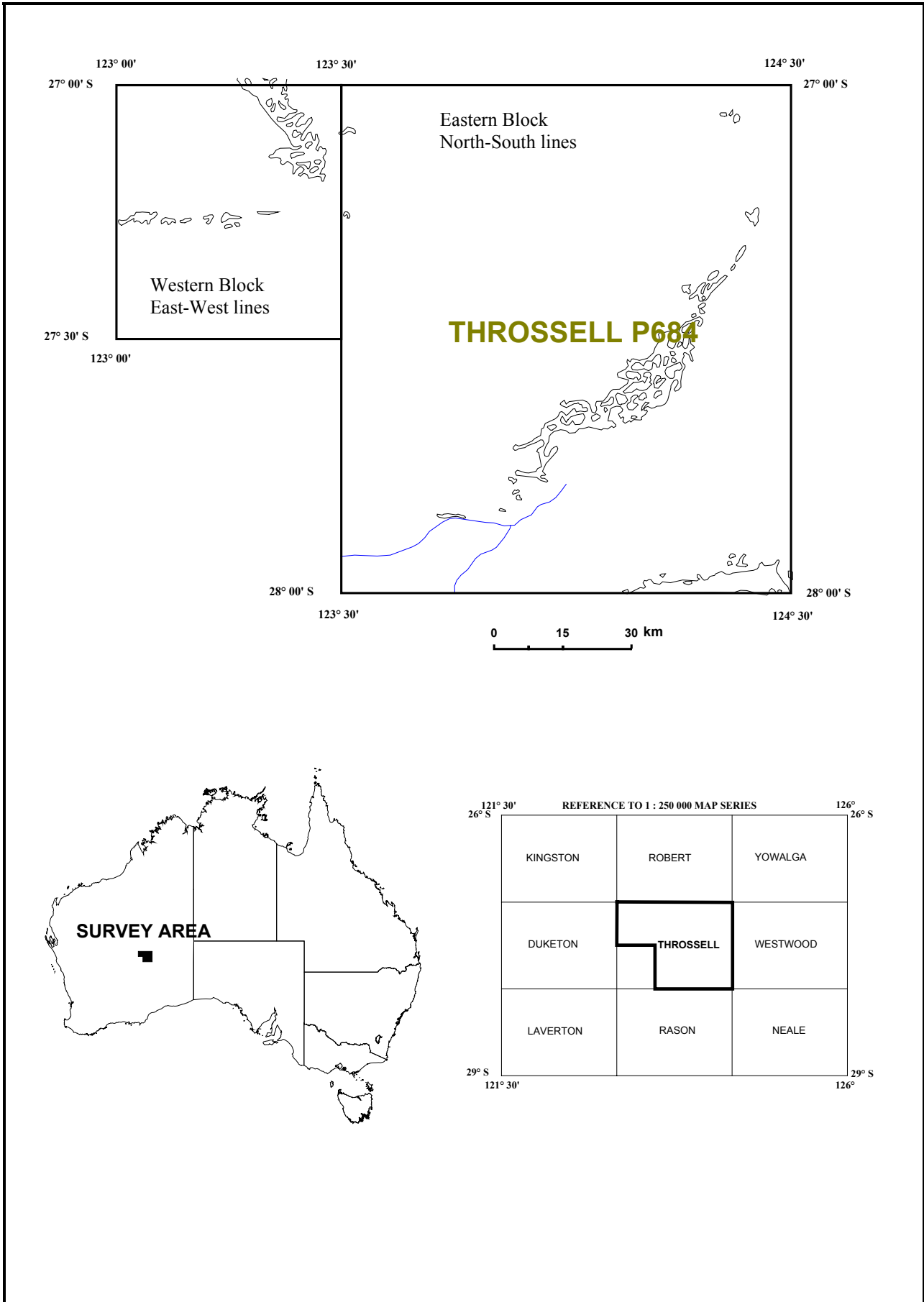

Appendix B-1

Flying Dates and Production Kilometres Flown

Date	Flight Number	Comments	Line / Tie Kilometres
9/05/98	145	Part of flight on Rason survey	200
10/05/98	146	Operations normal	978
11/05/98	147	Reflight due to problems with GPS data	0
12/05/98	148	Operations normal	814
12/05/98	149	Flight abandoned due poor weather	0
13/05/98	150	Operations normal	860
13/05/98	151	Operations normal	688
14/05/98	152	Operations normal	860
14/05/98	153	Operations normal	516
15/05/98	154	Operations normal	860
16/05/98	155	Operations normal	860
16/05/98	156	Operations normal	860
17/05/98	157	Operations normal	860
18/05/98	158	Operations normal	860
18/05/98	159	Operations normal	860
19/05/98	160	Operations normal	860
19/05/98	161	Operations normal	860
19/05/98		Ferry to Perth for aircraft service	0
22/05/98		Return ferry from Perth to Laverton	0
22/05/98	162	Compensation flight	0
23/05/98	163	Operations normal	860
23/05/98	164	Operations normal	1032
24/05/98	165	Operations normal	860
24/05/98	166	Operations normal	860
25/05/98	167	Operations normal	860
25/05/98	168	Operations normal	1032
26/05/98	169	Operations normal	860
26/05/98	170	Operations normal	860
27/05/98	171	Operations normal	888
29/05/98	172	Operations normal	688
29/05/98	173	Operations normal	906
30/05/98	174	Flight abandoned due to fog	0
30/05/98	175	Operations normal	308
31/05/98	176	Operations normal	888
31/05/98	177	Operations normal	854
1/06/98	178	Operations normal	1032
3/06/98	179	Operations normal	810
3/06/98	180	Operations normal	598
5/06/98	181	Some data lost due to GPS problems	516
5/06/98	182	Check and training flight	688
6/06/98	183	Check and training flight	688
6/06/98	184	Operations normal	962
7/06/98	185	Check and training flight	906
9/06/98	186	Operations normal	906
10/06/98	187	Operations normal	794
11/06/98	188	Operations normal	910
12/06/98	189	Operations normal	910
12/06/98	190	Operations normal	810
13/06/98	191	Operations normal	1010
13/06/98	192	Operations normal	866
14/06/98	193	Operations normal	810
14/06/98		Ferry to Perth for aircraft service	0
17/06/98		Return ferry from Perth to Laverton	0
17/06/98	194	Compensation flight	0
19/06/98	195	Flight abandoned due low cloud and fog	0
19/06/98	196	Operations normal	1310
20/06/98	197	Operations normal	910
20/06/98	198	Operations normal	710

Appendix B-2

SUMMARY

Total line kilometres flown	39,698
-----------------------------	--------

Productive flights	48
--------------------	----

Unproductive flights	10
----------------------	----

Abandoned flights (productive or not)	4
---------------------------------------	---

Total flights in survey	58
-------------------------	----

Unproductive flights consisted of:

Aircraft ferries	4
------------------	---

Compensation flights	2
----------------------	---

Abandoned flights	3
-------------------	---

Equipment failure	1
-------------------	---

Abandoned flights due to:

Equipment failure	0
-------------------	---

Poor weather	4
--------------	---

Active diurnal	0
----------------	---

Aircraft unserviceable	0
------------------------	---

Appendix C-1

Real Time Differential GPS

Real time differential GPS navigation is a method used to improve navigation accuracy. Line tracking using this method is more precise than by the single GPS receiver method thus allowing a pilot to fly an aircraft to an accuracy of better than 5 metres.

The primary navigation equipment used for this survey consisted of two Ashtech GPS receivers; one at a known position on the Laverton airport next to the terminal building, and the other in the aircraft. The ground based GPS receiver operated in non-differential mode and was not used as part of the real-time navigation system but it was used to record base station data for post flight differential processing. The aircraft GPS receiver was set up to run in differential mode.

Fugro Starfix Pty Ltd supplied satellite range corrections to the aircraft. The range corrections were calculated using Fugro's OmniSTAR Wide Area Differential GPS (WADGPS) service. OmniSTAR is a differential GPS service over Australia which is supported by a network of reference stations located throughout the continent to provide differential GPS corrections back to Fugro's Network Control Centre (NCC) in Perth. The WADGPS service allows monitoring of data from more than one reference station, quality control parameters, weighted least squares solution and improved accuracy over a single reference station.

The range corrections from all the available reference stations are transmitted to the NCC in Perth, then to an OmniSTAR Plus – Enhanced Differential System (EDS) receiver in the aircraft via the Optus satellite. The EDS receiver contains a demodulator board, an eight channel GPS engine, a computing engine and an interface and power supply board. The OmniSTAR Plus demodulator receives the Fugro compressed data from the satellite. The EDS receiver calculates a non-differentially corrected aircraft position from its internal GPS engine and using this position computes a "least squares method" optimum set of RTCM (Radio Technical Commission for Maritime Services) corrections for output to the Ashtech GPS receiver in RTCM 104 format.

The EDS receiver obtains satellite range data through an Ashtech plate antenna and range correction data through an OPTUS plate antenna, both mounted on the upper fuselage of the aircraft. The Ashtech GPS receiver in the aircraft uses the Ashtech plate antenna for receiving satellite range data. The EDS receiver outputs corrections to the aircraft GPS receiver at 4800 baud.

Appendix D-1

Specifications – G822A Caesium Magnetometer

Operating principle:	Self-oscillating caesium vapour magnetometer
Operating range:	20,000 nT to 95,000 nT
Active zones:	Sensor equator $\pm 10^\circ$ H_0 field sensor axis $\pm 10^\circ$, switchable or auto switch
Noise level:	≤ 0.01 nT peak to peak
Heading error:	$\leq \pm 0.25$ nT, ≤ 0.5 nT envelope
Power required:	26 to 32 VDC, 500 mA continuous, 750 mA while starting
Output:	2V peak to peak, frequency (Hz) = $3.498 H_0$ (nT)
Interface:	Larmor signal AC coupled to power input
Environmental:	-35°C to +50°C, humidity 95% non-condensing
Dimensions:	Sensor: 5 cm diameter, 18 cm long, 140 grams Electronics module: 5 cm wide, 5 cm high, 23 cm long, 170 g Sensor electronics cable: 135 cm to 270 cm long
Qualification:	MIL-I-45208, MIL-M-19595

Appendix E-1

Specifications – RMS Instruments Automatic Aeromagnetic Digital Compensator

Inputs:	one or two high sensitivity magnetometers of optical absorption type
Input frequency range:	70 kHz – 350 kHz – Cs sensor 140 kHz – 700 kHz – K sensor 560 kHz – 2800 kHz – He sensor 850 Hz – 4260 Hz – Overhauser
Magnetic field range:	20,000 nT – 100,000 nT
Resolution:	1 pT (picotesla)
Compensation procedure:	improvement ratio 10 – 20 (typical for total field) improvement ratio 20 – 100 (typical for gradient)
Accuracy of compensation:	0.35 nT standard deviation for the entire aircraft flight envelope in the bandwidth 0 – 1 Hz typical
Data output rate:	10 Hz
System frequency response:	0 – 0.9 Hz
Internal system noise:	less than 2 pT (standard deviation in the bandwidth 0– 1 Hz)
Duration of calibration flight:	5 – 8 minutes typical
Vector magnetometer:	Develco Model 9202–02 (3-axis fluxgate)
Microcomputer:	SBC-11/21 Plus (DEC) Front End LSI–11/73(DEC) Main CPU
Keyboard:	limited alphanumeric
Display:	green fluorescent, 80 character self scan panel
Outputs	serial data communication port RS232C – max. rate 19.2 K Baud parallel output port:– 16 bit with full handshaking (DRV11–J) (optional)
Power:	28 ± 4 VDC 5A, 150 W (for single magnetometer) 7A, 196 W (for gradiometer system)
Environmental:	Operating temperature: 0°C to 50°C Storage temperature -20°C to 55°C Relative humidity 0–99%, non-condensing Altitude 0–6000 m
Physical data:	console dimensions: 483 x 178 x 440 mm console weight: 12.5 kg power supply dimensions: 225 x 180 x 220 mm power supply weight: 5.5 kg

Appendix F-1

Specifications – GR820 Spectrometer System

A. Detector Controller

- Maximum number of crystals – 16. Each crystal has individual pole–zero cancellation, semi–gaussian shaping and advanced base line restoration circuitry.
- Continuous, individual–crystal spectrum analysis ensures that optimum system stabilisation is achieved. Resolution is calculated by a sophisticated gaussian curve fitting algorithm to perform an accurate centroid analysis of the selected stabilisation peak.
- High energy cosmic pulses are accumulated in a separate channel.
- Accurate pile-up rejection for simultaneous pulses allows qualitative gamma–ray spectrum analysis almost independent of the system count rate. Special circuitry analyses for pulse pile–up and permits only detector signals from single events to be analysed. Simultaneous events in adjacent crystals are added to reduce the Compton effect.
- Residual pulse pile–up at 100,000 counts/sec are less than 2%.

B. Analogue to digital converter (ADC)

- 50 MHz Wilkinson ramp ADC.
- Linearity – integral – less than 0.2% ; – differential – less than 1%.
- Average system dead-time is less than 5 msec/pulse.
- Live–time channel records the actual system live–time. This data is output with the digital data which allows post correction for system dead–time to an accuracy of 0.1%.
- Number of channels – selection of 256 channels or 512 channel operation.
- Maximum number of counts/channel – 65,535 (16 bits).
- The lower threshold – manually selectable from channel 2 to channel 50 (20–500 keV).
- The upper threshold is set to 3 MeV. All pulses above 3 MeV are accumulated in the cosmic channel as a direct measure of cosmic ray activity.
- ADC offset set from the keyboard.
- The maximum input count rate is 100,000 cps.

C. System outputs

- Visual display – the front panel display is a 640x200 electroluminescent (EL) high contrast graphics display which allows full spectrum display, system set–up and various parameter monitoring functions. In the spectrum display mode, the region of interest and cursor may be viewed by channel number or directly in keV.
- The internal channel number to energy level (keV) conversion table compensates for non–linearity of the detector's light output.
- The front panel has a 21 button keyboard for easy operator control.
- The system's operation is fully menu driven.
- Digital outputs:
 - RS–232 port (1200 to 19200 baud).
 - IEEE-488 bus output – talk listen/talk only.
- Geometrics GR–800 output format.

Appendix F-2

- Some system functions can be controlled remotely by an external computer via the RS–232 and the IEEE–488 digital ports.
- Analogue output:
 - 4 channels of ROI data can be selected for output on the analogue port. The outputs have 10 bit resolution (0–10V). Scaling can be set from the keyboard (100–50K counts/sec FSD) and output data may be raw or stripped using internally stored calibration constants. Analogue output wraps at FSD limits and is dead-time corrected.

D. Miscellaneous

- Regions of interest (ROI): 8 ROIs can be selected. The upper and lower thresholds can be individually set over the entire spectrum range.
- The first 4 ROIs are available for digital and analogue output. The second 4 ROIs are available only for digital output on the RS–232 or the IEEE–488 ports.
- System resolution. Detector resolution is automatically computed for each (and summed crystals) during peak analysis and is displayed for operator monitoring when required. The summed down resolution is also output on the data stream.
- System test. At power on, a full system test of all internal handshaking is performed. Included in the testing is the lithium back-up battery, the system ram memory, display handshaking, the systems configuration (options installed), the selected detectors (checked via ADC analysis) and peripheral handshaking response.
- Configuration menus. The configuration menus allow the selection of the number of detectors in use, confidence levels for gain analysis, maximum crystal resolution levels for each detector (with operator warning if levels exceeded), output configurations for analogue and digital data and various special display/monitoring functions.
- Maintenance. A set of special menus allows the user to test and calibrate many system functions including system test, ADC offset, low level discriminator etc.
- Power: 28V – 1.25 amps

E. Detectors

The crystals are housed in a specially designed hi–impact polystyrene cases using low background materials for minimum signal attenuation. Full thermal and internal shock protection allows the units to be directly mounted to the floor. A very low noise, high voltage power supply is housed in each pack so high voltage is not present in the connecting cables. A unique preamplifier with special processing for signal optimisation is used. The GPX–1024 has 4 crystals with a total volume of 16.78 litres

- Outputs: Individual BNC connectors output each crystal’s signal separately
- Size: GPX–1024 : (73x51x30 cm)
- Weight: GPX–1024 : 84 kg
- Power: 28V @ 0.5A/crystal pack
- Temperature limitations
 - Closed pack: storage -40°C to +60°C, operation -40°C to +60°C
 - Open pack: not recommended
- Temperature gradient
 - Closed pack: -40°C to +50°C (instantaneous)
 - Open pack: a change of 1°C/hr

Appendix G-1

Specifications – G823B Caesium Base Station Magnetometer

Sensor Module:

Operating principle:	Self-oscillating caesium vapour magnetometer
Operating range:	20,000 nT to 95,000 nT
Active zones:	Sensor equator $\pm 10^\circ$ H_0 field sensor axis $\pm 10^\circ$, switchable or auto switch
Noise level:	≤ 0.01 nT peak to peak
Heading error:	$\leq \pm 0.25$ nT, ≤ 0.5 nT envelope
Power required:	26 to 32 VDC, 500 mA continuous, 750 mA while starting
Output:	2V peak to peak, frequency (Hz) = 3.498 H_0 (nT)
Interface:	Larmor signal AC coupled to power input
Environmental:	-35°C to +50°C, humidity 95% non-condensing
Dimensions:	Sensor: 5 cm diameter, 18 cm long, 140 grams Electronics module: 5 cm wide, 5 cm high, 23 cm long, 170 g Sensor electronics cable: 135 cm to 270 cm long
Qualification:	MIL-I-45208, MIL-M-19595

Counter Module:

Operating frequency range:	70 kHz to 350 kHz
Operating field range:	20,000 nT to 100,000 nT
Cycle rate:	variable from 20 s to 0.01 s in 0.005 s increments

Sensitivity (nT) (Counter LSB)	Noise (RMS) (nT)	Earth's Field (nT)	Sample Rate (Hz)
0.001	0.003	30,000	1
0.002	0.004	50,000	
0.003	0.005	70,000	
0.013	0.015	30,000	10
0.023	0.020	50,000	
0.032	0.025	70,000	

Julian clock:	Resolution: 0.01 seconds Drift: < 1 second/day
A/D channels:	Internal: one channel for Larmor signal amplitude External: five, 12 bit channels
Data output:	RS-232 standard serial port
Operating temperature:	-25°C to +50°C
Power:	CM-201 alone runs on 5 V @ 0.30 A
Compatibility:	PC based systems

APPENDIX H-1

Aircraft Data Acquisition System

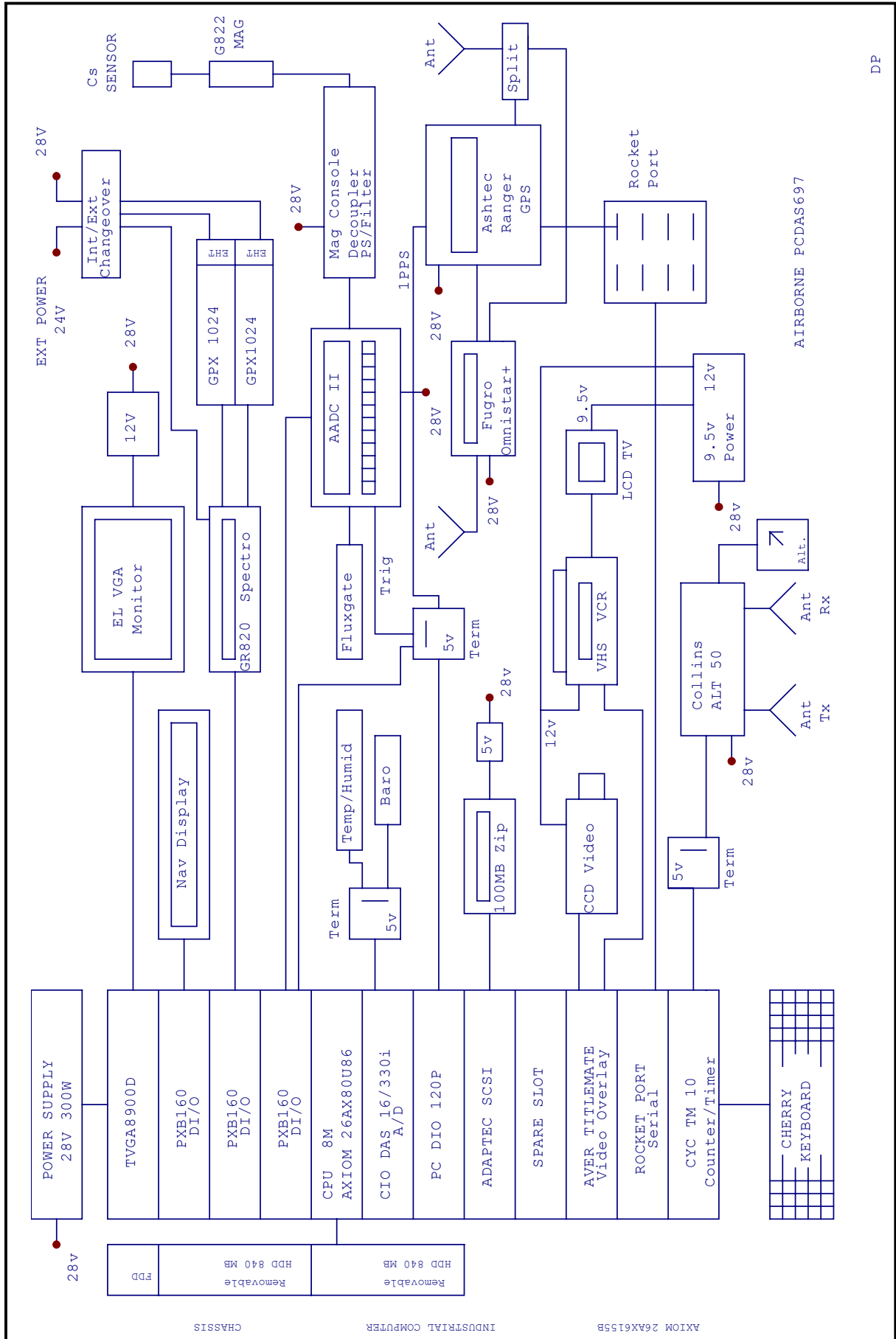

Appendix I-1

Compensation Results

Compensation 1

Date flown	1 May 1998
Dates used	2 to 9 May
Air conditioner off	Not acceptable and not used
Air conditioner on	$\sigma_u = 0.2393$
	$\sigma_c = 0.03472$
	$\lambda = 6.9$
	$v = 24.6$

Compensation 2

Date flown	2 May 1998
Dates used	2 to 9 May
Air conditioner off	$\sigma_u = 0.1763$
	$\sigma_c = 0.03227$
	$\lambda = 5.5$
	$v = 25.0$
Air conditioner on	Not acceptable and not used

Compensation 3

Date flown	22 May 1998
Date used	23 May to 14 June
Air conditioner off	$\sigma_u = 0.1825$
	$\sigma_c = 0.02117$
	$\lambda = 8.6$
	$v = 28.0$
Air conditioner on	$\sigma_u = 0.1634$
	$\sigma_c = 0.08700$
	$\lambda = 1.9$
	$v = 33.6$

Appendix I-2

Compensation 4

Date flown	17 June 1998
Date used	19 to 20 June
Air conditioner off	$\sigma_u = 0.2034$
	$\sigma_c = 0.02581$
	$\lambda = 7.9$
	$v = 27.0$
Air conditioner on	Not flown

σ_u = standard deviation of data recorded during manoeuvres

σ_c = standard deviation of data recorded during manoeuvres after compensation corrections have been applied

λ = improvement ratio = σ_u / σ_c

v = vector norm, a measure of the degree of difficulty in calculating the coefficients

Appendix J-1

Gamma-ray Spectrometer Test Line Location

Eastern Block - Coordinates 123° 30' 00"E 28° 14' 00"S to 123° 34' 30"E 28° 11' 30"S
Western Block - Coordinates 122° 50' 00"E 27° 36' 00"S to 122° 51' 42"E 27° 31' 18"S

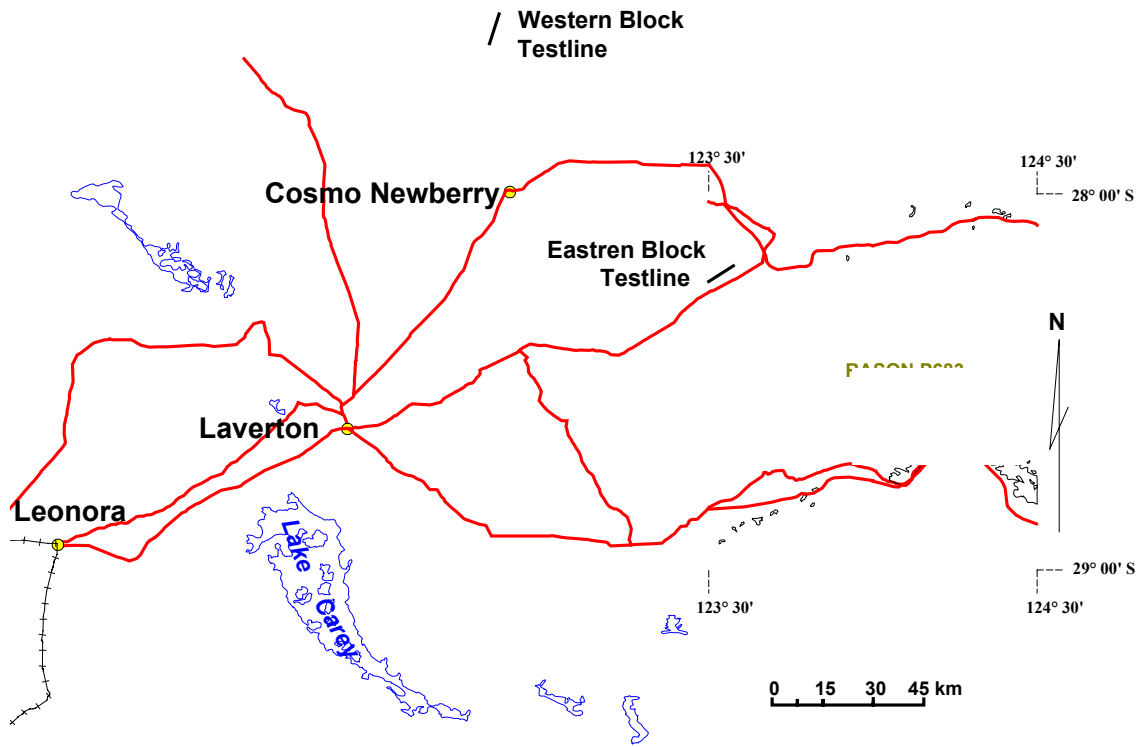

Appendix K-1

The World Geodetic System 1984 Datum

For geophysical surveys the real shape of the earth has to be considered. An ellipsoid of revolution around the earth's north-south axis approximates the earth's shape. This figure is called the spheroid. The mean sea level equipotential surface describing the shape of the earth is known as the geoid.

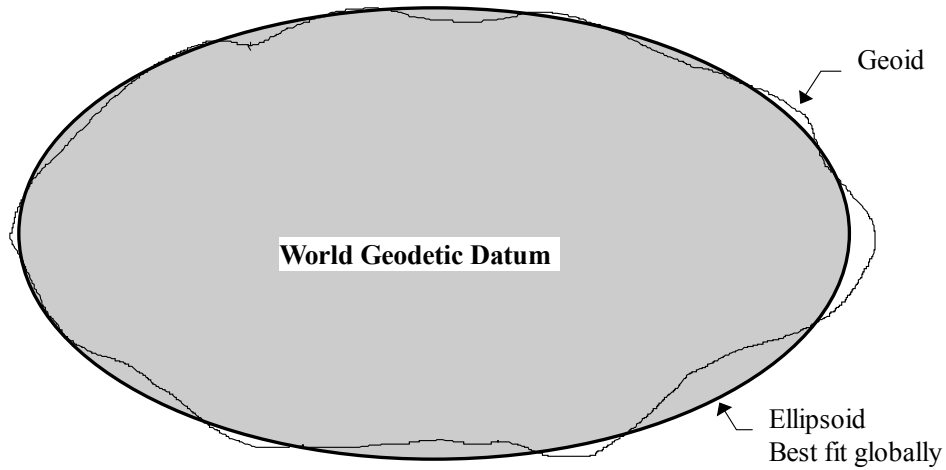

Calculated positions from the GPS are in the World Geodetic System 1984 (WGS84). The WGS84 datum is a global geocentric reference datum that has as its origin at the Earth's centre of mass.

This geocentric datum comprises a spheroid (also known as an ellipsoid) oriented and located in such a manner as to "best-fit" the geoid over the entire earth.

The WGS84 datum is defined by a semi-major axis (a) and flattening (f) of the selected ellipsoid.

$$\begin{aligned} a &= 6378137 \text{ m} \\ f &= 1/298.2572 \end{aligned}$$

Appendix L-1

Corrections to Differential GPS Navigation Data

(a) "Ranger" corrections

Using the range data which are recorded internally on the aircraft and base GPS receivers every second, "Ranger" calculates the correct positions at one second intervals along the flight path. These corrected positions are utilised to correct the raw aircraft position data recorded every half second.

Discontinuities (steps) and spikes sometimes occur in the raw aircraft GPS data. These may also be manifested as steps in the correction set. When such steps in the raw aircraft GPS data occur between successive correction values, the corrections are linearly interpolated to the step boundary using corrections from the appropriate side of the step.

If multiple steps in the raw GPS data occur between successive correction values, it is impossible to interpolate corrections over this interval, in which case the intervening GPS data are set to undefined.

(b) Infilling "Ranger" data

Data gaps can appear in the "Ranger" data and not in the raw aircraft data. To infill these gaps the difference between the raw aircraft data and the "Ranger" data are calculated at each point for which both exist. It is these differences that are actually infilled, therefore preserving the shape of the aircraft's flight path over the gap in the "Ranger" data whilst still moving the navigation data to the absolute locations defined by the "Ranger" data. The maximum gap that will be infilled by this method is 10 s (700 m).

(c) Infilling final navigation data

For a variety of reasons, data gaps may appear in the final navigation data. Common causes are the multiple steps as in (a) above and gaps in the "Ranger" data. These gaps in the final navigation data are linearly infilled. The maximum gap size is 10 seconds.

(d) Generation of terrain data

The terrain data is generated by subtracting the radar altimeter clearance from the "Ranger" ellipsoidal height. The terrain data are linearly interpolated to match the half second sampling interval of the "Ranger" corrected navigation data.

(e) Low Pass filter

The problem described in (c) can lead to small steps in the data where the original steps were too small to detect so were not corrected. A low pass 5 point Fuller filter with a cut-off wavelength of 175 m was passed over the navigation data. The terrain data are not filtered.

(f) Reference navigation data to position of magnetometer sensor

The calculated GPS positions refer to the position of the GPS receiver's antenna. Since the magnetometer is the most position-sensitive instrument, all position data are shifted 11.4 m towards the rear of the aircraft to correspond with the position of the magnetometer sensor. In the processing of the gamma-ray and digital elevation model data parallax corrections are made to account for this shift.

(g) Barometric infill of height data gaps

Appendix L-2

Whenever gaps less than 5 km in the GPS height data occur, these gaps are infilled with height data calculated using the recorded barometric and temperature data. Gaps greater than 5 km require the line to be reflowed or an infill line flown.

Appendix M-1

Comparison of Third Order Gravity Station Elevations and Digital Elevation Model Derived from the Airborne Data

Station Number	Latitude (degrees)	Longitude (degrees)	Horizontal distance from gravity station to airborne sample point (m)	Gravity Station Elevation (m)	Airborne Derived Elevation (m)	Difference (m)
72010551	-27.394170	124.353330	0.77	380.60	378.46	-2.14
72015121	-27.476830	124.307500	1.71	380.30	382.52	2.22
72015099	-27.301000	124.384830	1.90	375.90	375.83	-0.07
72016014	-27.563830	124.116500	5.34	372.90	372.55	-0.35
72013946	-27.747000	124.067670	7.97	415.50	428.15	12.65
72010749	-27.636830	124.185670	9.58	372.60	381.33	8.73
71006023	-27.143330	124.376670	10.13	377.03	374.28	-2.75
71006018	-27.156670	123.811670	10.27	527.25	534.02	6.77
72018321	-27.265000	124.498330	11.84	410.70	413.27	2.57
72015147	-27.684670	124.226500	12.83	404.30	414.03	9.73
72010816	-27.746330	124.100330	13.35	425.20	437.44	12.24
71006096	-27.858330	124.275000	13.91	412.21	406.52	-5.69
72010956	-27.919330	123.868500	14.04	376.60	376.32	-0.28
72016019	-27.602500	124.096330	14.14	372.50	372.45	-0.05
72010654	-27.587330	124.372670	15.51	429.60	422.79	-6.81
72010811	-27.713500	124.088170	15.59	392.20	398.98	6.78
72015172	-27.776830	124.011000	15.85	390.60	399.53	8.93
72015185	-27.854830	123.921170	16.96	382.30	388.63	6.33
72015176	-27.803330	123.986500	17.05	388.50	392.54	4.04
71006082	-27.755000	123.580000	17.13	464.98	464.92	-0.06
72018264	-27.415000	124.311670	17.46	376.00	378.69	2.69
72010502	-27.314170	124.437830	17.59	393.70	390.80	-2.90
72015126	-27.523000	124.303330	18.70	385.00	386.01	1.01
71006095	-27.856670	124.145000	18.78	412.50	410.46	-2.04
72010820	-27.811500	124.132670	19.45	426.50	432.94	6.44
72018261	-27.423330	124.303330	19.85	374.60	373.76	-0.84
71006073	-27.655000	123.811670	19.92	421.84	417.54	-4.30
72015188	-27.864170	123.893170	20.62	383.50	392.89	9.39
72010651	-27.572000	124.315500	20.95	394.40	400.21	5.81
71006008	-27.041670	124.035000	21.44	454.08	454.96	0.88
72010603	-27.489330	124.364670	22.11	408.80	408.13	-0.67
71006050	-27.433330	123.820000	22.77	466.32	457.86	-8.46
72015142	-27.658830	124.270830	22.84	405.70	412.26	6.56
71006043	-27.348330	124.153330	22.86	423.73	420.66	-3.07
72015095	-27.278000	124.417170	22.96	377.00	377.64	0.64
72010812	-27.695330	124.084170	22.97	382.40	387.93	5.53
72010409	-27.112330	124.421670	23.13	380.70	376.67	-4.03
72013956	-27.541000	124.299170	23.47	383.30	385.22	1.92
72013947	-27.724500	124.104500	25.07	403.40	412.48	9.08
72018318	-27.273330	124.486670	26.11	407.10	408.19	1.09
72015191	-27.884500	123.872330	26.46	383.40	379.72	-3.68
72010903	-27.861170	124.011000	26.59	437.20	447.48	10.28
72015088	-27.224670	124.445500	26.96	381.80	384.51	2.71
72010852	-27.795830	124.047170	27.09	418.50	434.24	15.74
72018267	-27.405000	124.320000	28.06	375.10	378.08	2.98
72013936	-27.890000	123.681670	28.23	404.10	405.74	1.64
72010604	-27.493830	124.385000	28.28	423.20	423.24	0.04
72015137	-27.615830	124.283500	28.44	398.50	398.63	0.13
72015125	-27.512830	124.303170	28.65	381.80	385.09	3.29

Appendix M-2

72016012	-27.545330	124.137170	28.65	372.90	370.99	-1.91
72010702	-27.647170	124.312000	30.23	420.60	428.20	7.60
72010907	-27.808000	123.905330	30.23	378.70	373.53	-5.17
72016002	-27.460330	124.275330	30.30	373.60	374.25	0.65
72015120	-27.467330	124.307670	31.40	379.70	380.74	1.04
71008062	-27.325000	124.490000	31.48	420.94	424.57	3.63
71006085	-27.756670	123.921670	31.50	375.85	371.93	-3.92
72010851	-27.787330	124.030670	33.15	399.60	403.06	3.46
72010854	-27.805670	124.084330	33.37	433.60	438.17	4.57
72010855	-27.810330	124.104670	33.49	431.70	438.97	7.27
71006037	-27.350000	123.475000	34.41	496.20	494.70	-1.50
72010853	-27.801000	124.067330	34.88	421.70	434.76	13.06
72015114	-27.415830	124.316000	35.16	375.90	380.14	4.24
72010746	-27.677330	124.198170	35.40	391.10	395.83	4.73
72018258	-27.431670	124.295000	35.93	372.70	374.43	1.73
72015082	-27.188330	124.490170	36.18	420.00	424.10	4.10
72013965	-27.210330	124.461670	36.19	393.00	393.90	0.90
72015100	-27.310330	124.377000	36.86	376.70	376.26	-0.44
71006027	-27.266670	123.588330	36.90	451.94	460.02	8.08
72015177	-27.810830	123.978670	37.77	387.30	392.57	5.27
72010423	-27.231670	124.494170	37.89	405.90	409.49	3.59
72018270	-27.396670	124.328330	38.26	377.80	376.66	-1.14
72013941	-27.874330	123.881170	39.71	381.50	385.27	3.77
72015096	-27.285670	124.409670	41.33	376.90	377.13	0.23
72018320	-27.268330	124.495000	41.43	408.00	415.31	7.31
72015090	-27.235170	124.430000	41.51	377.00	377.94	0.94
71006039	-27.355000	123.690000	41.63	499.10	501.01	1.91
72015178	-27.818170	123.974670	42.38	386.40	394.42	8.02
72010503	-27.323330	124.454330	42.57	401.40	400.65	-0.75
71006076	-27.651670	124.161670	42.99	370.88	372.76	1.88
72015199	-27.935500	123.819330	43.07	386.10	389.76	3.66
72010951	-27.894500	123.840500	43.29	380.90	378.83	-2.07
72010904	-27.876830	124.015330	44.35	419.30	411.39	-7.91
72010704	-27.643830	124.350330	45.40	453.80	438.72	-15.08
71009607	-27.446670	124.031670	45.71	447.86	449.53	1.67
72013940	-27.874330	123.839670	46.28	383.20	382.44	-0.76
72010602	-27.484670	124.343670	46.84	393.40	394.27	0.87
72015103	-27.331830	124.369000	46.95	376.80	375.91	-0.89
72010405	-27.166330	124.478500	47.12	412.40	409.55	-2.85
72015140	-27.643170	124.271500	47.36	397.10	399.51	2.41
72010508	-27.284170	124.324330	48.10	380.30	382.67	2.37
72016008	-27.508830	124.198330	48.24	373.20	369.96	-3.24
72010954	-27.865830	123.786830	48.36	386.90	387.01	0.11
71006015	-27.148330	123.473330	48.76	439.69	440.38	0.69
71009603	-27.250000	123.248330	48.77	443.51	442.17	-1.34
72018305	-27.313330	124.430000	49.00	385.80	388.09	2.29
72018314	-27.286670	124.468330	49.09	395.10	400.30	5.20
71006046	-27.443330	123.248330	49.79	464.96	466.60	1.64

Appendix N-1

Summary Specifications of Adjoining Survey

Acquired and processed by: World Geoscience Corporation (WGC)
WGC Job Number: 2021_225
Date flown: 15 October 1989 to 13 January 1990

Data lies on: Throssell and Rason 1:250 000 sheets
Jutson, Mulgabiddy Creek and Bailey 1:100 000 sheets

Boundary coordinates: 123° 00' 00" -27° 30' 00"
123° 30' 00" -27° 30' 00"
123° 30' 00" -29° 00' 00"
123° 00' 00" -29° 00' 00"

Flight line spacing: 200 m
Tie line spacing: 2000 m
Flight line direction: East- West
Tie line direction: North-South
Nominal terrain clearance: 60 m
Navigation: Syledis STR4 UHF positioning system

Flight line numbers: 710010-715610 & 810011-812820
Tie line numbers: 727291-727530 & 827330-827570

Aircraft: VH-ADH Cessna 206 Stationair II
VH-AZG Cessna 206 Stationair II

Magnetometer: Scrintrex V201 (Split Beam Caesium)
Resolution: 0.04 nT
Cycle rate: 0.3 s
Sample interval: 17 m

Spectrometer: 256 channel Exploranium GR800B
Volume: 16.78 litres
Cycle rate: 1.2 s
Sample interval: 68 m

Data acquisition system: Aerodata Digital Acquisition System
Computer: Hewlett Packard 9825
Chart recorder: 8 Channel Watanabe MC 6700

Appendix O-1
Geophysical Maps

Name	Type	Interval or Scale	Reference Number
------	------	-------------------	------------------

1:250 000 scale

Throssell	TMI Contours	30 nT	22-1/G51-15/1
	Dose Rate Contours	2 nG/hr	22-1/G51-15/18
	DEM Contours	2 m	22-1/G51-15/19

1:100 000 scale

Strawbridge	TMI Contours	10 nT	22-2/G51-15/1-1
	Dose Rate Contours	1 nG/hr	22-2/G51-15/18-1
	Flight line System		22-2/G51-15/3-1
Blaxland	TMI Contours	5 nT	22-2/G51-15/1-2
	Dose Rate Contours	1 nG/hr	22-2/G51-15/18-2
	Flight line System		22-2/G51-15/3-2
Buldya	TMI Contours	5 nT	22-2/G51-15/1-3
	Dose Rate Contours	1 nG/hr	22-2/G51-15/18-3
	Flight line System		22-2/G51-15/3-3
Jutson	TMI Contours	10 nT	22-2/G51-15/1-4
	Dose Rate Contours	1 nG/hr	22-2/G51-15/18-4
	Flight line System		22-2/G51-15/3-4
Yamarna	TMI Contours	10 nT	22-2/G51-15/1-5
	Dose Rate Contours	1 nG/hr	22-2/G51-15/18-5
	Flight line System		22-2/G51-15/3-5
Lake Throssell	TMI Contours	5 nT	22-2/G51-15/1-6
	Dose Rate Contours	1 nG/hr	22-2/G51-15/18-6
	Flight line System		22-2/G51-15/3-6

Appendix P-1

AGSO Archive Data and Magnetic Tape Format for Airborne Geophysical Data

CONTENTS

1. THE AGSO SEQUENTIAL FILE STRUCTURE	2
(i) Introduction	2
(ii) General File Structure	2
(iii) Channels and Samples.....	2
(iv) Segment Directory Record (SDR).....	2
(v) Data Record (DAR).....	3
(vi) No Data Value	3
(vii) Standard Data Channels	4
2. PHYSICAL FORMAT OF STORAGE MEDIA.....	7
(i) General	7
(ii) Physical Parameters of Media	7
(iii) Tape Structure	7
(iv) Physical Records and Blocks	7

TABLES

Appendix P-2

1. THE AGSO SEQUENTIAL FILE STRUCTURE

(i) Introduction

This appendix describes the general sequential file structure used by AGSO to store airborne geophysical data. For the purpose of this survey 14 data chains are involved for each line and tie. They are:

- channel 4 edition 1 (processed navigation data)
- channel 4 edition 2 (processed magnetic data)
- channel 4 edition 3 (processed spectrometric data)
- channel 4 edition 4 (processed digital elevation model data)
- channel 6 edition 2 (terrain and altimeter data)
- channel 6 edition 3 (diurnal data)
- channel 8 edition 1 (raw compensated magnetic data)
- channel 8 edition 2 (fluxgate data and uncompensated magnetic data)
- channel 14 edition 2 (pressure, temperature, humidity, cosmic data)
- channel 16 edition 2 (raw navigation data)
- channel 17 edition 1 (raw 256 channel spectrometer data)
- channel 18 edition 1 (gridding flag for magnetics data)
- channel 18 edition 1 (gridding flag for gamma-ray spectrometer data)
- channel 18 edition 1 (gridding flag for digital elevation model data)

(ii) General File Structure

The information pertaining to each traverse (line or tie) is held on the file as a separate entity called a segment. Segments are separated from each other by industry standard EOF records. The end of the file is indicated by two or more consecutive EOF records. Each segment consists of two types of records. Both types are 5120 characters long.

Segment Directory Record (SDR):	the first record on each segment; defines the data content of the segment.
Data Records (DAR's):	hold the measured data values.

(iii) Channels and Samples

Data are recorded at regular intervals in time along a traverse. The data recorded at one instant of time are held as any ordered set or sub-set. Each set is held logically distinct and referred to as a channel. The data records in a segment hold all the information for one channel in the form of a data chain, then all the data for the next channel and so on for as many channels as the segment holds.

Each channel is uniquely defined by a channel number and an edition number. The measurement(s) taken for a channel at a given time is called a sample. Samples are held within each channel in increasing order of fiducial (time).

In defining channels the channel number can be used to define the sample format and the edition type of the data. For example, within AGSO, samples with format (longitude, latitude, value, value....) have a channel number of 4 with edition 2 for magnetic data and edition 3 for gamma-ray spectrometric data.

(iv) Segment Directory Record (SDR)

Lines and ties are uniquely identified as follows:

Appendix P-3

Project number:	a unique number to identify the survey
Group number:	a unique number within a survey for each flight made. That is, several lines may be recorded on one flight (group). AGSO convention is for group numbers to lie between 001 and 999 inclusive.
Segment numbers:	a unique number within a survey for a line or tie. AGSO convention is for ordinary line numbers to lie between 1000 and 9999 inclusive and tie line numbers between 100 and 999 inclusive.

The segment directory record identifies the data segment at Project, Group and Segment level and defines the data channels, their structure and the location of their data chains in the segment. Each SDR consists of one or more 10 word blocks. The first, the Segment Identification Block (SIB), identifies the segment and gives the number of data channels held in the segment.

For this survey the number of data channels is nine as mentioned in the introduction. Subsequent blocks, one for each data channel, define the data channels and their location within the segment. These are called Channel Identification Blocks (CIB's). A typical SDR is shown in Figure 1 and its exact format given in Table 1. All unused words in the SDR are set to zero.

The last word in the record in the past has been used as check sum and represents the sum of all the other words in the record. The check sum word is no longer used and is set to zero.

The overall record format is 2I9, 509I10, I12.

(v) **Data Record (DAR)**

These each contain 512 values. The first two are fiducials giving the fiducial range of the samples contained in the record. The next 508 represent data values, the second last is always zero (to maintain compatibility with our random access file format) and the last is a record check sum representing the sum of all other values in the record.

If a record is the last one in a data chain for a given channel all unused values are set to zero, with the next channel commencing at the start of the next data record. The N data records in a segment are numbered from 2 to N+1, the SDR being regarded as record one in a segment, with records for a given channel following each other sequentially. The data record addresses in the channel identification block of the SDR refer to this sequential numbering of the data records. A typical segment is shown in Figure 1 and the exact format of a data record given in Table 2.

The overall format of each data record is: 2I9, 509I10, I12.

(vi) **No Data Value**

For a variety of reasons it is sometimes necessary to flag a data value to indicate it is to be ignored. This is achieved by replacing the data word in question by the value 536870912. If a gap exists in a data chain each word of every sample involved must be replaced by 536870912, the so-called missing value. Thus a 1:1 correspondence is maintained between the fiducials encompassed by a data chain and its samples.

Appendix P-4

(vii) Standard Data Channels

The standard AGSO data channels are:

channel 4 edition 1 (processed navigation data)
channel 4 edition 2 (processed magnetic data)
channel 4 edition 3 (processed spectrometric data)
channel 4 edition 4 (processed digital elevation model data)
channel 6 edition 2 (terrain and altimeter data)
channel 6 edition 3 (diurnal data)
channel 8 edition 1 (raw compensated magnetic data)
channel 8 edition 2 (fluxgate data and uncompensated magnetic data)
channel 14 edition 2 (pressure, temperature, humidity, cosmic data)
channel 16 edition 2 (raw navigation data)
channel 17 edition 1 (raw 256 channel spectrometer data)
channel 18 edition 1 (gridding flag for magnetics data)
channel 18 edition 1 (gridding flag for gamma-ray spectrometer data)
channel 18 edition 1 (gridding flag for digital elevation model data)

C4 E1 - Corrected GPS Navigation Data

Channel number = 4
Edition number = 1
Sample size = 2 words
word 1 = longitude (degrees) * 1 000 000
word 2 = latitude (degrees) * 1 000 000

C4 E2 - Corrected Total Magnetic Intensity Data

Channel number = 4
Edition number = 2
Sample size = 4 words
word 1 and word 2 as for C4 E1
word 3 = final non micro-levelled TMI (nT) * 1000
word 4 = final micro-levelled TMI (nT) * 1000

C4 E3 - Corrected Gamma-ray Spectrometer Data

Channel number = 4
Edition number = 3
Sample size = 7 words
word 1 = parallax corrected longitude (degrees) * 1 000 000
word 2 = parallax corrected latitude (degrees) * 1 000 000
word 3 = final total count (nG/hr) * 1000
word 4 = final potassium (%) * 1000
word 5 = final uranium (ppm) * 1000
word 6 = final thorium (ppm) * 1000
word 7 = radar altimeter (m above ground level) * 1000

C4 E4 - Corrected Digital Elevation Model Data

Channel number = 4
Edition number = 4
Sample size = 3 words
word 1 = parallax corrected longitude (degrees) * 1 000 000
word 2 = parallax corrected latitude (degrees) * 1 000 000
word 3 = final terrain elevation (m above sea level) * 1000

C6 E2 – Terrain and Altimeter Data

Channel number = 6
Edition number = 2
Sample size = 2 words

Appendix P-5

word 1 = radar altimeter (m above ground level) * 1000
word 2 = raw terrain elevation (m above sea level) * 1000

C6 E3 - Diurnal Data

Channel number = 6
Edition number = 3
sample size = 2 words
word 1 = diurnal (nT) * 1000
word 2 = filtered diurnal (nT) * 1000

C8 E1 - Raw Magnetic Data

channel number = 8
edition number = 1
sample size = 1 word
word 1 = compensated TMI (nT) * 1000

C8 E2 - Fluxgate and Uncompensated Magnetic Data

channel number = 8
edition number = 2
sample size = 5 words
word 1 = fluxgate X (nT) * 1000
word 2 = fluxgate Y (nT) * 1000
word 3 = fluxgate Z (nT) * 1000
word 4 = fluxgate T (nT) * 1000
word 5 = uncompensated magnetic data (nT) * 1000

Appendix P-6

C14 E2 - Pressure, Temperature, Humidity and Cosmic Data

Channel number = 14
Edition number = 2
Sample size = 4 words
word 1 = pressure (millibars) * 1000
word 2 = temperature (degrees Celsius) * 1000
word 3 = humidity (%) * 1000
word 4 = cosmic channel (counts) * 1000

C16 E2 - Raw Navigation Data

channel number = 16
edition number = 2
sample size = 6 words
word 1 = longitude (degrees) * 1 000 000
word 2 = latitude (degrees) * 1 000 000
word 3 = raw aircraft elevation (m above WGS84 ellipsoid) * 1000
word 4 = final aircraft elevation (m above WGS84 ellipsoid) * 1000
word 5 = GPS time (seconds) * 1000 (GPS time is recorded in seconds
from midnight the previous Sunday)
word 6 = GPS Quality * 1000 (flag indicates whether data are real time corrected)

C17 E1 - Raw 256 Channel Gamma-Ray Spectrometric Data

Channel number = 17
Edition number = 1
Sample size = 290 words
word 1 - 34 = various control information words
word 35 - 290 = individual 256 channels from channel 1 to 256
(counts per second * 1000)

C18 E1 – Gridding Flag – Magnetic Data

Channel number = 18
Edition number = 1
Sample size = 1 word
word 1 = magnetics gridding flag (0 = USE and 1=IGNORE)

C18 E2 – Gridding Flag – Gamma-ray Spectrometric Data

channel number = 18
edition number = 2
sample size = 1 word
word 1 = gamma-ray spectrometrics gridding flag (0 = USE and 1=IGNORE)

C18 E3 – Gridding Flag – Digital Elevation Model Data

channel number = 18
edition number = 3
sample size = 1 word
word 1 = digital elevation model gridding flag (0 = USE and 1=IGNORE)

Appendix P-7

2. PHYSICAL FORMAT OF STORAGE MEDIA

(i) General

Each exabyte magnetic tape or CD-ROM consists of a sequence of segments, each segment consisting of one or more physical records. Segments are to be separated by one EOF marker. The end of all information on the media must be flagged by two or more consecutive EOF markers. Industry standard EOF records apply. Records are to be fixed length and each block is to contain one record.

(ii) Physical Parameters of Media

- (a) Exabyte Tapes are 8 mm wide, computer grade standard data cartridge.
- (b) CD-ROM are 74 minute (640 Mb) standard media.
- (c) Each media have an external label identifying the airborne survey, character code, recording density, date data written.

(iii) Tape Structure

- (a) Written in ASCII.
- (b) No multi-tape files.

(iv) Physical Records and Blocks

- (a) Fixed length records of 5120 characters.
- (b) One record per block.

Appendix P-8

Table 1

Segment Directory Record Format

1. Segment Identification Block

Word	Content And Use	Format
1	Project identification	I9
2	Group identification	I9
3	Segment identification	I10
4	Number of channels on segment	I10
5	Date code – yymmdd	I10
6	Fiducial factor – (fiducial size in seconds)	I10
7	Time of day at fiducial zero in seconds	I10
8	Bearing in degrees (0 – 359) measured east of north	I10
9	Altitude in metres above sea level	I10
10	Ground clearance in m	I10

2. Channel Identification Block (for the Nth channel)

Word	Content And Use	Format
1	Channel code	I10
2	Edition numbers	I10
3	Fiducial interval between samples	I10
4	Number of data values (words) per sample	I10
5	Address of first data record for channel	I10
6	Address of last sample in data chain	I10
7	Fiducial of first sample in data chain	I10
8	Fiducial of last sample in data chain	I10
9	Unused – set to zero	I10
10	Unused – set to zero	I10

Appendix P-9

Table 2

Data Record Format

Word	Content And Use	Format
1	Fiducial at first data sample in record	I9
2	Fiducial at last data sample in record	I9
3	First word of first sample	I10
4	Second word of first sample	I10
.		
.		
.		
.		
.		
.		
.	First word of second sample	I10
.	Second word of second sample	I10
.		
.		
.	Etc	
511	Always unused – set to zero	I10
512	Always unused – set to zero	I12

- NOTE:
1. A data sample can be of any length greater than zero.
 2. Each record contains an integral number of samples. This may lead to several unused words at the end of the record which are set to zero.
 - ie. If a sample is 7 words long 72 samples will fit in a data record and words 507–510 will be set to zero.