

**BALLARAT  
AIRBORNE GEOPHYSICAL SURVEY, 1992 -  
OPERATIONS REPORT**

**by**

**L. M. Richardson**

**Australian Geological Survey Organisation  
Record 1993/41**

**DEPARTMENT OF PRIMARY INDUSTRIES AND ENERGY**

Minister for Resources: The Hon. Michael Lee  
Secretary: Greg Taylor

**AUSTRALIAN GEOLOGICAL SURVEY ORGANISATION**

Executive Director: Roye Rutland

Commonwealth of Australia

**ISSN: 1039-0073**

**ISBN: 0 642 19333 9**

This work is copyright. Apart from any fair dealings for the purposes of study, research, criticism or review, as permitted under the Copyright Act, no part may be reproduced by any process without written permission. Copyright is the responsibility of the Executive Director, Australian Geological Survey Organisation. Inquiries should be directed to the **Principal Information Officer, Australian Geological Survey Organisation, GPO Box 378, Canberra City, ACT, 2601.**

# CONTENTS

## SUMMARY

<b>1.</b>	<b>SURVEY AREA AND PARAMETERS</b>	<b>1</b>
	(i) Area Description	1
	(ii) Survey Parameters	1
<b>2.</b>	<b>LOGISTICS</b>	<b>1</b>
	(i) Operating Base and Dates of Flying	1
	(ii) Survey Aircraft and Field Crew	1
<b>3.</b>	<b>SURVEY EQUIPMENT</b>	<b>2</b>
	(i) Major equipment	2
	(ii) Navigation	2
	(iii) Magnetometer	3
	(iv) Gamma-ray Spectrometer	3
	(v) Altimeter	4
	(vi) Barometer and Thermometer	4
	(vii) Base Station Magnetometer	4
	(viii) Data Acquisition	4
<b>4.</b>	<b>CALIBRATION</b>	<b>5</b>
	(i) Compensation for the Magnetic Field of the Aircraft	5
	(ii) Gamma-ray Spectrometer Calibration	5
<b>5.</b>	<b>DATA PROCESSING</b>	<b>6</b>
	(i) Data Checking and Editing	6
	(ii) Flight Path Recovery	6
	(iii) Magnetic Data Processing	7
	(iv) Gamma-ray Spectrometric Data Processing	7
	(v) Final Products	9
	<b>REFERENCES</b>	<b>9</b>
	<b>APPENDICES</b>	

## **APPENDICES**

- A. Survey Area
- B. Flying Dates and Line Kilometres Flown
- C. Australian Geodetic Datum
- D. Magnetometer Specifications
- E. Specifications of Gamma-ray Spectrometer Components
- F. Aircraft Acquisition System
- G. Compensation Results
- H. Gamma-ray Spectrometer Test Line Location
- I. Corrections to Navigation Data
- J. AGSO Archive Data, Grid and Magnetic Tape Format for Airborne Geophysical Data
- K. AADC Specifications
- L. Base Station Magnetometer Specifications
- M. Standard Map Products

## SUMMARY

The Australian Geological Survey Organisation (formerly the Bureau of Mineral Resources, Geology and Geophysics) flew an airborne geophysical survey of 45 500 line km over a large part of the Ballarat 1:250 000 Map Sheet area during March and April, 1992.

This survey, which formed part of the National Geoscience Mapping Accord, was flown along east-west flight lines 400m apart at an altitude of 100m above ground level. An area in the south-west of the survey area was infilled with additional lines to reduce the line separation to 200m. The NSW Department of Mineral Resources funded the additional flying.

The total magnetic intensity and gamma-ray spectrometric data which were collected during the survey, have been processed and are available for purchase, in both digital (position located data and grids) and map form, from the Australian Geological Survey Organisation.

## 1. SURVEY AREA AND PARAMETERS

### (i) Area Description

The Ballarat airborne survey covers the Ballarat 1:250 000 topographic map sheet area apart from the Ararat 1:100 000 map sheet. A small extension to the Willaura 1:100 000 map sheet to longitude 142°25'55" E was included. The exact survey area is shown in Appendix A.

### (ii) Survey Parameters

Altitude:	100 m nominal terrain clearance	
Flight line direction:	East - West	
Tie line direction:	North - South	
Survey Line spacing:		
	West of 142°45' E	East of 142°45' E
Flight line spacing:	200 m	400 m
Tie line spacing:	2000 m	4000 m
Survey distance		
400 m survey	Lines:	35306 km.
	Ties:	3423 km.
200 m infill	Lines:	4361 km.
	Ties:	1480 km.
	Total distance:	44570 km.
Sampling interval		
Magnetics:	0.1 seconds (approx 7m)	
Gamma-ray spectrometrics/GPS/Doppler/Altimeter:	1.0 seconds (approx 67m)	
Barometric pressure/Temperature:	10.0 seconds (approx 670m)	

## 2. LOGISTICS

### (i) Operating Base and Dates of Flying

#### (a) Operating Base

Aircraft and crew were based at Ballarat in Victoria for the duration of the survey from 25 February to 27 April 1992.

#### (b) Flying Dates

Compensation flights for the magnetic field of the aircraft were flown between 27 and 29 February. Production flying commenced on the 29th February and continued through to the 25 April. Appendix B summarises flying days and distance flown.

### (ii) Survey Aircraft and Field Crew

- (a) Aircraft  
Aero Commander 500 S "Shrike", VH-BGE

(b) Field Crew	
Party Leader:	Murray Richardson
Technician:	Trevor Dalziell
Operators:	Lars Rickardsson "Curly" Wilcox
Pilots:	Capt. Howard Quick (Skywest Aviation) Capt. Robert Courtenay ( " " )

### 3. SURVEY EQUIPMENT

#### (i) Major Equipment

Magnetometer:	Geometrics G833 helium magnetometer
Compensator:	RMS Instruments Automatic Aeromagnetic Digital Compensator
Gamma-ray spectrometer:	Geometrics gamma-ray spectrometer consisting of GR900 interface, two DET1024 spectrometer crystal detectors (33.56 l total) and Norland IT-5410 Analog-To-Digital converter
Altimeter:	Collins ALT-50 radar altimeter
Barometer:	AGSO digital - Setra sensor
Thermometer:	AGSO digital - RS sensor
Navigation:	Ashtech XII "Ranger" GPS receivers and Ashtech "Ranger" differential processing software
Doppler:	Racal (Decca) doppler antenna (80561 CAD) Sperry C 14 D compass
Video:	National colour video camera (WV CL 302E) National VCR (NV 180) National LCD TV (TCL 3A) National Time Date Generator (WJ 810)
Acquisition hardware:	HP-A400 computer, HP9122 720 Kb 3.5 inch dual floppy disc drive and HP Thinkjet printer
Acquisition software:	AGSO-developed HP assembler language program

#### (ii) Navigation

##### (a) GPS Navigation System

Aircraft navigation was carried out by an Ashtech XII global positioning system (GPS). A receiver in the aircraft received range data from satellites every second and calculated the current latitude and longitude coordinates (WGS84) of the aircraft. The range data were recorded internally in the GPS receiver every five seconds.

The calculated position of the aircraft was recorded on the aircraft acquisition system every second and was used to provide the pilot with aircraft guidance information on an LCD display.

To enable differential GPS post flight processing, a second GPS receiver was set up in AGSO's field office caravan as a GPS base station and internally recorded range data every five seconds. The error in position of the post processed flight path data is approximately 5 - 10 metres.

The position of the base station GPS receiver was accurately determined by differential GPS surveying using a permanent survey marker (PSM#9) at the airport as a fixed reference.

The determined base station GPS coordinates (WGS 84) were:

Longitude	: 143°47'21.22' E
Latitude	: 37°30'52.02' S
Ellipsoidal height	: 410.073 m

#### (b) Doppler Navigation System

Doppler navigation data were used as a secondary navigation system for the aircraft. The doppler data were used as a back-up for the main navigation system (GPS) and to infill gaps (<10 km) in the GPS data.

#### (c) Video Flight Path Recording

The aircraft's flight path was recorded on a VHS video system consisting of a National colour video camera with wide angle lens, a National VCR and a National LCD TV. This system was also used for locating start and end positions for the gamma-ray spectrometer test lines.

### **(iii) Magnetometer**

A Geometrics G833 helium magnetometer, with the sensor mounted in a boom attached to the rear of the aircraft, was used for the survey. The specifications of the magnetometer are summarised in Appendix D.

The recorded total magnetic field data were compensated in real time using an RMS Instruments automatic aeromagnetic digital compensator (AADC). The AADC compensates for the effects of aircraft motion and heading. The specifications of the AADC are summarised in Appendix K. Compensation procedures are described in Chapter 4.

Unfiltered compensated total magnetic field intensity data were recorded on the aircraft acquisition system.

### **(iv) Gamma-ray Spectrometer**

A Geometrics gamma-ray spectrometer, comprising two DET1024 crystal detectors with a total

volume of 33.56 litres, was used. The crystal gains and temperatures were controlled by a Geometrics GR900 Detector Interface console. Analog to digital conversion was achieved through a Norland IT-5410 Analog-To-Digital converter. Appendix E summarises the specifications of the gamma-ray spectrometer components.

Five channels of data were recorded once a second using the following window limits:

Total Count	0.40 - 3.00 MeV
Potassium	1.35 - 1.57 MeV
Uranium	1.63 - 1.89 MeV
Thorium	2.42 - 2.82 MeV
Cosmic	3.00 - 6.00 MeV

A cumulative 256 channel spectrum between 0.0 MeV and 3.0 MeV was recorded every 100 seconds. Total system dead-time was reduced by electronically suppressing counts in the 0.0 MeV - 0.3 MeV energy range before these signals reached the analogue to digital converter. Gamma-rays in this energy range are not very diagnostic in airborne geophysical surveying.

#### **(v) Altimeter**

A Collins ALT-50 radar altimeter was used to measure ground clearance. The radar altimeter display indicates ground clearance from 0-2000 feet. The manufacturer's specifications claim a +/- 2% accuracy for the ALT-50 system.

#### **(vi) Barometer and Thermometer**

Atmospheric temperature and pressure were measured using a digital barometer (Setra sensor) and digital thermometer (RS sensor). Although both of these units were built by the AGSO, the sensors were factory calibrated and no AGSO calibrations were performed.

#### **(vii) Base Station Magnetometer**

Daily variations of the Earth's magnetic field were monitored using a Geometrics G866 proton precession base station magnetometer, the specifications of which are given in Appendix L. Data from the base station were telemetered back to the AGSO's field office caravan for display and recording on an Amstrad PC512 lap-top computer. The telemetry system used AGSO-built modems incorporating Phillips 828 UHF mobile radiotelephone transmit boards at a frequency of 471.8 Mhz.

The base station was set up in an area of shallow magnetic gradient area, away from cultural influences and within telemetry range of AGSO's office caravan at the Ballarat airport. Throughout the survey, base station data were recorded every twenty seconds during production flights.

#### **(viii) Data Acquisition**

The acquisition program and system are run using a HP-A400 computer with data recorded on a HP9122 720 Kb disc drive using 3.5 inch floppy discs. The acquisition program was written in-house at AGSO. The data are displayed in real time in the aircraft in analogue form on a HP Thinkjet printer. A schematic diagram of the aircraft's acquisition system is shown in Appendix F.

## 4. CALIBRATION

### (i) Compensation for the Magnetic Field of the Aircraft

Compensation flights were flown prior to the start of the survey and after each aircraft service. They were flown approximately 60 kilometres north of Ballarat over Cairn Curran reservoir.

The compensation flights were flown at an altitude of 2900 m above sea level and the magnetic field was monitored to find an area of low magnetic gradient suitable for the compensation. The compensation comprises a series of rolls( $\pm 10^\circ$ ), pitches( $\pm 5^\circ$ ) and yaws( $\pm 5^\circ$ ) in the four cardinal headings to enable the AADC to calculate correction coefficients needed to remove aircraft manoeuvre noise. Each manoeuvre component was of 20 seconds duration.

The compensation manoeuvres were repeated after calculation of the coefficients to check the compensation quality. Peak-to-peak noise during repeat manoeuvres and after the final compensation was at worst 0.30 nT. On normal survey flights, noise levels from all sources were generally less than 0.2 nT peak-to-peak.

The AADC calculates basic statistics which reflect the degree of merit of the compensation. These include the standard deviation of the recorded data without corrections applied, the standard deviation with the corrections applied, the improvement ratio (the ratio of the standard deviation of the recorded data without and with the corrections applied) and the vector norm (the degree of difficulty in calculating the corrections). These statistics are given for all compensations in Appendix G.

### (ii) Gamma-ray Spectrometer Calibration

Crystal alignment checks were performed (using a small thorium source) on 26 February and after each aircraft service. The resolution of the gamma-ray spectrometer system was measured using the full width at half maximum method (IAEA, 1991). Adjustments were made such that the resolution of the thorium (2.62 MeV) photopeak was 6% or better. Gamma-ray spectrometer channels were positioned such that the thorium photopeak was centred within one channel ( $\pm 12$  keV) of channel 223.

Gamma-ray spectrometric test lines were flown at the beginning and end of each production flight. These lines were flown at survey altitude along a dirt road and lasted 100 seconds or approximately 6.5 kilometres. The location of the test line used for the Ballarat survey is shown in Appendix H. This line was used for the duration of the survey.

Although background corrections for gamma-ray spectrometrics are calculated using a full spectrum method (Minty, 1992) at AGSO, background estimation lines were flown as a means of data checking. Background lines, of 300 seconds duration, were flown at 915 metres above ground level at the start and end of each flight.

After each flight, statistics were calculated from data recorded between fixed reference points, observed on video, along the test line and for background lines. These statistics were recorded in spreadsheet form. Statistics for each flight were compared with the preceding flight in order to detect any irregularities. In particular, the difference between the average in the total count channel for the test line and the background line was analysed. This value never varied by greater than 10% for the test line, well inside a 15% variation which would be considered acceptable.

## 5. DATA PROCESSING

Flight path recovery, and data checking and editing were performed at the survey base. Merging of geophysical and navigation data, and magnetic and gamma-ray spectrometric data processing were carried out in Canberra using Geophysical Mapping Section's airborne data processing system, ARGUS.

### (i) Data Checking and Editing

Data recorded on the aircraft acquisition system were transferred on a flight by flight basis to a hard disk in a Compaq 386 personal computer, and edited using AGSO-developed software for missing values, noise, spikes or steps. All the recorded data were displayed for each survey line and any errors were interactively corrected. Anomalies arising from cultural influences, such as sheds, houses and fences, were usually not edited out. They were only edited out if they caused severe noise or caused the magnetometer to lose lock.

### (ii) Flight Path Recovery

Range data recorded internally on both GPS receivers were post-processed daily using "Ranger" - an Ashtech propriety program.

The correction data calculated by "Ranger" were later applied to the GPS data recorded on the aircraft acquisition system. As well as the standard "Ranger" corrections, other acquisition system specific corrections were applied. The full correction procedure is described in Appendix J and is outlined below.

- (a) Position calculation delay correction.
- (b) Fiducial synchronisatation correction.
- (c) "Ranger" corrections.
- (d) Low pass filter.
- (e) Coordinate system conversion.
- (f) Reference navigation data to position of magnetometer sensor.
- (g) Doppler infill of gaps.

The fully corrected flight path was plotted each day to check the position of survey lines and their spacing. Navigation reflies were determined by the following criteria:

Line Spacing	Across Track Deviation	Distance along line
200 m	40 m	greater than 3 km
400 m	80 m	greater than 5 km

When both the across track deviation and along line distance were exceeded the survey line was reflight.

### **(iii) Magnetic Data Processing**

Raw magnetic data were merged with the navigation data, and diurnal variation corrections were removed. The IGRF 1990 geomagnetic reference field, updated to 1992.25 and for an altitude of 500 m above sea level (the mean on-shore survey altitude), was then subtracted from the data. The IGRF was calculated from the coefficients defined by the IAGA (1991). All values were adjusted by a constant so that the average residual magnetic field value was approximately 5000 nT.

The data were levelled using standard tie line levelling procedures. The steps involved in tie line levelling were as follows.

- (a) Tie line 450 was chosen as a reference tie.
- (b) A low pass 11 point convolution filter with a cut-off wavelength of 60 m was passed over the data prior to sampling crossover points (flight line - tie line intersections). Note that these filtered data were only used for the crossover analysis and the final data have not been filtered.
- (c) All other ties were levelled to tie line 450 using degree three polynomial adjustments.
- (d) Lines were adjusted on a flight by flight basis to minimise the differences at line/tie crossover points, using degree one polynomial adjustments.
- (e) Ties were then adjusted to minimise crossover differences, using degree three polynomial adjustments.
- (f) Finally the lines were adjusted individually to minimise crossover differences, using degree three polynomial adjustments.

After tie line levelling, the data were micro-levelled using the technique described by Minty (1991). Filter characteristics were

- (a) Low pass filter in the flight line direction with a cut-off wavelength of 5 km
- (b) High pass filter in the tie line direction with a cut-off wavelength of 1.6 km.
- (c) Correction strings were low pass filtered with a cut-off wavelength of 1 km before being applied to the line data.

The micro-levelled data were gridded using Brigg's minimum curvature technique, employing a 80 m (3') grid cell size.

### **(iv) Gamma-ray Spectrometric Data Processing.**

Raw gamma-ray spectrometric and altimeter data were merged with the navigation data. Background estimates for each of the four recording windows were removed. These estimates were determined as follows

- (a) Aircraft and Cosmic Background  
Minty and Richardson (1989) derived aircraft and cosmic spectra for the

AGSO aircraft from high altitude calibration flights.

(b) Atmospheric Radon Background

Full spectrum analysis (Minty, 1992) was used to calculate the radon contribution to the background in the uranium window.

(c) Total Background

The total background in the uranium window is the sum of the aircraft, cosmic and radon background. The total count and potassium window backgrounds were estimated directly from the uranium background since they are linearly dependent (Grasty, 1975). The thorium window was considered to be unaffected by atmospheric radon, so total thorium background was estimated from the aircraft and cosmic backgrounds.

The data were corrected for height attenuation and reduced to a nominal flying height of 100 m. Where the aircraft attained a height of 300 m or higher above the ground gamma-ray spectrometric data have been set to undefined. Height attenuation corrections were made using the following formula

$$NC = N \exp(-u(H-h))$$

where

NC = corrected counts

N = uncorrected counts

H = nominal flying height

h = measured flying height

u = attenuation coefficient

for total count  $u = 0.00656$

for potassium  $u = 0.00755$

for uranium  $u = 0.00557$

for thorium  $u = 0.00557$

Channel interaction corrections (stripping) to correct for Compton scattering were then applied to the data. Stripping ratios for the AGSO system were determined by Minty and others (1990) using portable calibration sources. The corrections were applied as follows

$$NTH(\text{corrected}) = NTH$$

$$NU(\text{corrected}) = NU - A \times NTH$$

$$NK(\text{corrected}) = NK - B \times NTH - C \times NU(\text{corrected})$$

where

NTH = counts in thorium channel

NU = counts in uranium channel

NK = counts in potassium channel

A = 0.506

B = 0.521

C = 0.902

Total count data were levelled in much the same way as the magnetic data. However, prior to sampling the crossover points, a 11 point convolution filter with a cut-off wavelength of 600 m was passed over the data.

The potassium and thorium channels were levelled in the same way as the total count data.

The uranium channel was levelled using a technique utilising cross channel correlation information between the uranium channel and the potassium and thorium channels (Green, 1987). This technique determines a constant correction for each line.

All channels were gridded to a 80 m (3') cell size using Brigg's minimum curvature technique. Prior to sampling total count data for gridding, the data were filtered with a seven point low pass convolution filter with a cut-off wavelength of 400 m. As in the case of filtering prior to crossover sampling, the data were only filtered for the purpose of gridding and the final data were not filtered. Potassium, thorium and uranium data were also filtered prior to gridding.

## **(v) Final Products**

### **(a) Standard AGSO geophysical products**

A standard AGSO set of geophysical maps have been produced at scales of 1:250 000, 1:100 000 and 1:50 000 for the entire survey area. Profiles and flight path maps were produced using ARGUS programs. Contour maps were produced using the GIPSI processing system. The standard set of maps produced are shown in Appendix M.

Final processed line data and grids were archived in the normal AGSO ARGUS format - 6250 bpi on nine track magnetic tape in ASCII format (Appendix J). Both micro-levelled and non micro-levelled versions of the magnetic line data have been archived.

## **References**

- Grasty, R. L., 1975 - Uranium measurements by airborne gamma-ray spectrometry. *Geophysics*, **40**, 503-519.
- Green, A. A., 1987 - Levelling airborne gamma-radiation data using between-channel correlation information. *Geophysics*, **52**, 1557-1562.
- International Association of Geomagnetism and Aeronomy, 1991 - Division V Working Group 8. International Geomagnetic Reference Field, 1991 Revision. *Journal of Geomagnetism and Geoelectricity*, **43**, 1007-1012.
- International Atomic Energy Agency, 1991 - Airborne Gamma Ray Spectrometer Surveying. *International Atomic Energy Agency Technical Reports Series Number 323*, IAEA Vienna.
- Minty, B. R. S., Morse, M. P., and Richardson, L. M., 1990 - Portable calibration sources for airborne gamma-ray spectrometers. *Exploration Geophysics*, **21**, 187-195.
- Minty, B. R. S., 1991 - Simple micro-levelling for aeromagnetic data. *Exploration Geophysics*, **22**, 591-592.
- Minty, B. R. S., 1992 - Airborne gamma-ray spectrometric background estimation using full spectrum analysis. *Geophysics*, **57**, 279-287.
- Minty, B. R. S., and Richardson, L. M., 1989 - Calibration of the BMR airborne gamma-ray spectrometers upward-looking detector, February 1989. *Bureau of Mineral Resources, Australia, Record 1989/8*.

# APPENDIX A

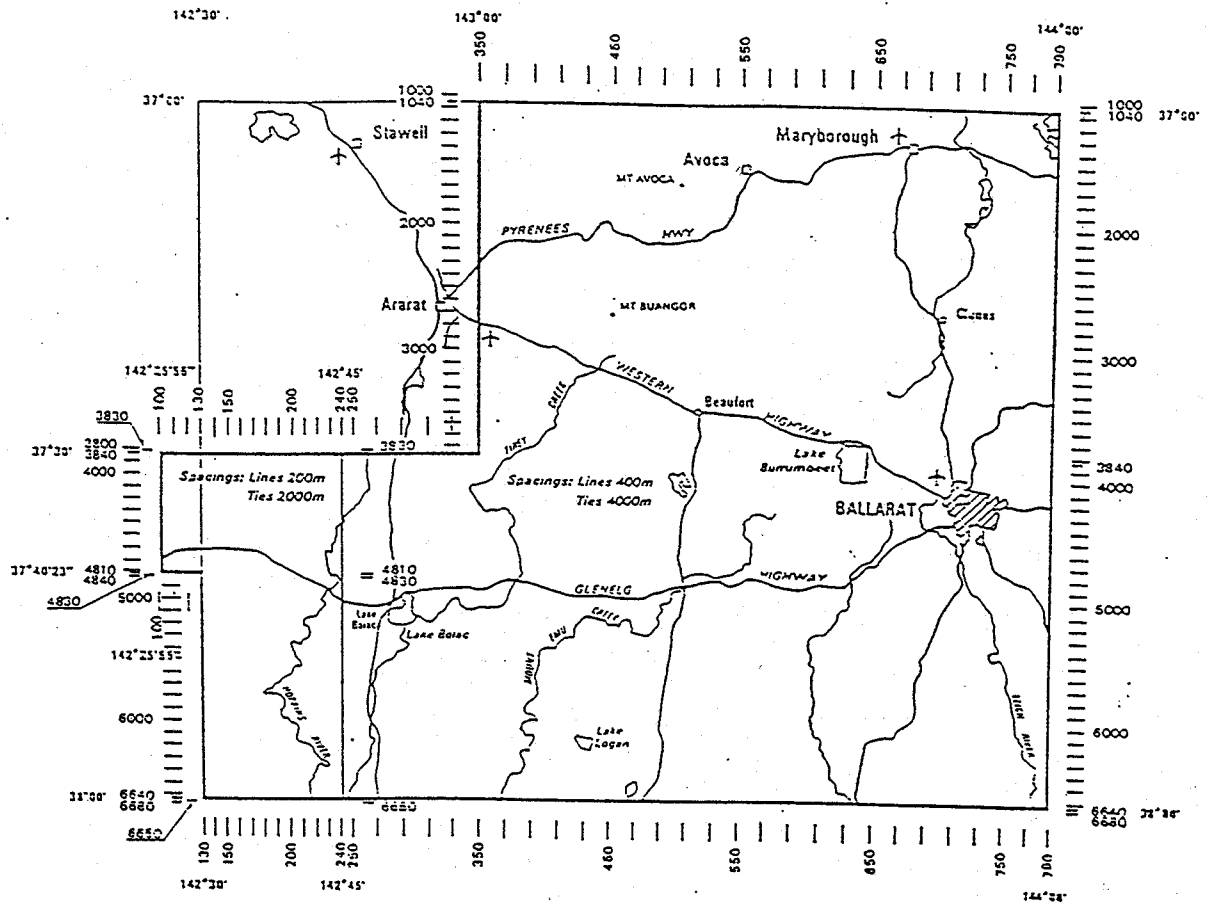

AIRBORNE SURVEY, BALLARAT, VIC, 1992

PROJECT No 582

LOCALITY MAP AND FLIGHT-LINE SYSTEM

0 40 km

INDEX TO 1:250 000 MAP SHEETS

HORSHAM	ST ARNAUD	BENDIGO
HAMILTON	BALLARAT	MELBOURNE
PORTLAND	COLAC	QUEENSLIFF

22/J54-971

## APPENDIX B-1

### FLYING DATES AND LINE KILOMETRES FLOWN

DATE	FLIGHT No.	COMMENTS	LINE KM
28/2/92	111	Compensation flight	0
28/2/92	112	Flight aborted - mag noise	0
29/2/92	113	Flight aborted - mag noise	0
29/2/92	114	First survey flight	200
2/3/92	115	Operations normal	400
2/3/92	116	Operations normal	600
4/3/92	117	Operations normal	600
4/3/92	118	Operations normal	800
5/3/92	119	Flight aborted - data recording error	520
6/3/92	120	Operations normal	800
6/3/92	121	Operations normal	600
7/3/92	122	Operations normal	800
7/3/92	123	Operations normal	600
8/3/92	124	Operations normal	800
9/3/92	126	Operations normal	800
9/3/92	127	Operations normal	800
10/3/92	128	Operations normal	800
10/3/92	129	Operations normal	600
10/3/92		Aircraft to Melbourne for service	
12/3/92		Aircraft returns to Ballarat	
12/3/92	130	Operations normal/Compensation	200
13/3/92	131	Operations normal	800
13/3/92	132	Operations normal	200
14/3/92	133	Operations normal	670
14/3/92	134	Operations normal	800
16/3/92	135	Operations normal	800
16/3/92	136	Operations normal	840
17/3/92	137	Operations normal	870
17/3/92	138	Operations normal	870
19/3/92	139	Operations normal	580
20/3/92	140	Operations normal	575
20/3/92	141	Operations normal	460
21/3/92	142	Operations normal	575
22/3/92	143	Operations normal	870
23/3/92	144	Operations normal	770
23/3/92	145	Operations normal	605
24/3/92	146	Flight aborted - Fog	0
24/3/92	147	Operations normal	580
24/3/92	148	Operations normal	580
25/3/92	149	Operations normal	800
25/3/92	150	Operations normal	580
26/3/92	151	Operations normal	870
26/3/92	152	Operations normal	870
28/3/92	153	Operations normal	870
28/3/92	154	Operations normal	870
30/3/92	155	Operations normal	400
30/3/92	156	Operations normal	590
31/3/92	157	Operations normal	810

## APPENDIX B-2

31/3/92	158	Operations normal	630
1/4/92	159	Flight aborted - Bad weather	0
1/4/92	160	Cloverleaf - GPS test	0
2/4/92	161	Operations normal	430
2/4/92	162	Operations normal	750
3/4/92	163	Operations normal	290
3/4/92	164	Flight aborted - magnetometer losing lock	0
4/4/92	165	Flight aborted - magnetometer noisy	0
4/4/92	166	Test flight - for magnetometer	0
7/4/92	167	Operations normal	300
8/4/92	168	Flight aborted - GPS not working properly	0
8/4/92	169	Operations normal	590
8/4/92	170	Flight aborted - GPS not working properly	0
8/4/92	171	Operations normal	470
9/4/92	172	Operations normal	760
9/4/92	173	Flight aborted - GPS satellite problems	150
10/4/92	174	Operations normal	1200
10/4/92	175	Flight aborted - GPS problems & mag noise	0
11/4/92	176	Operations normal	940
12/4/92	177	Operations normal	880
13/4/92		Aircraft to Melbourne for service	
15/4/92		Aircraft returns to Ballarat	
16/4/92	178	Operations normal/Compensation	960
17/4/92	179	Flight aborted - Fog	0
17/4/92	180	Operations normal	600
17/4/92	181	Operations normal	600
18/4/92	182	Operations normal	820
18/4/92	183	Operations normal	900
19/4/92	184	Operations normal	415
19/4/92	185	Operations normal	600
20/4/92	186	Operations normal	940
21/4/92	187	Operations normal	600
21/4/92	188	Operations normal	460
22/4/92	189	Operations normal	540
23/4/92	190	Operations normal	150
23/4/92	191	Operations normal	600
24/4/92	192	Flight aborted - Fog and low cloud	0
24/4/92	193	Flight aborted - Fog and low cloud	0
24/4/92	194	Operations normal	530
25/4/92	195	Operations normal	190
Total flights in survey		85	44320 line km.
Aircraft test flights		2	
Compensation flights		3	1160 line km
Problem free flights		64	42490 line km.
Problem flights		2	670 line km.
Aborted flights		14	
-Reason flight abandoned		weather	5 flights
		magnetometer	4 flights
		gps	4 flights
		other	1 flight

## APPENDIX C

### THE AUSTRALIAN GEODETIC DATUM

For geophysical surveys the real shape of the earth has to be considered. An ellipsoid of revolution around the earth's north-south axis approximates the earth's shape. This figure is called the spheroid. The mean sea level equipotential surface describing the shape of the earth is known as the geoid.

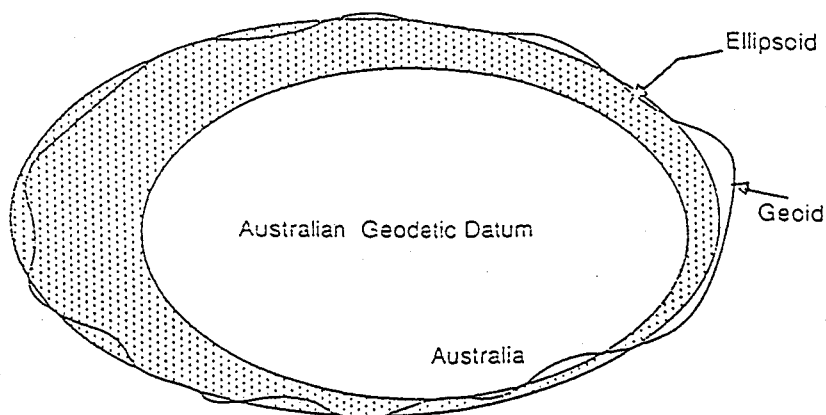

Calculated positions from the GPS are in the WGS84 geodetic system. During processing these positions are converted to the local reference datum, AGD66 or Australian Geodetic Datum 1966.

This non-geocentric datum comprises the Australian National Spheroid (ANS) oriented and located in such a manner as to "best-fit" the geoid over the Australian continent.

The Australian geodetic datum is defined by a semi-major axis ( $a$ ) and flattening ( $f$ ) of the selected ellipsoid and the geodetic coordinates of the origin or fundamental station. The origin is referred to as the Johnston Origin. For AGD66:

$a$	= 6378160 m
$f$	= 1/298.25
latitude	= 25°56'54.5515" S
longitude	= 133°12'30.0771" E
Height	= 571.2 m above ellipsoid

For an ideal local datum the geoid-spheroid separation over a region should be small and uniform. At the time of the AGD66 adjustment it was assumed that the geoid and the spheroid coincided at Johnston.

## APPENDIX D

### Specifications – G833 Helium Magnetometer

Operating range:	20,000 to 95,000 nT
Temperature:	-20 to +50 °C
Sensitivity:	0.0032 nT/root Hz RMS
Bandwidth:	350 Hz (-3dB point)
Loop scan rate:	1000 cycles/second
Input power:	28 V DC, 6 A max
Output signal:	At Helium gyromagnetic frequency, approximately 28.02468 Hz/nT. 3 volts peak to peak
Dimensions:	Sensor cell - 80 mm diameter x 145 mm length Scan processor - 270 x 120 x 85 mm Control panel - 48.26 cm rack mount
Weight:	approximately 6 kg

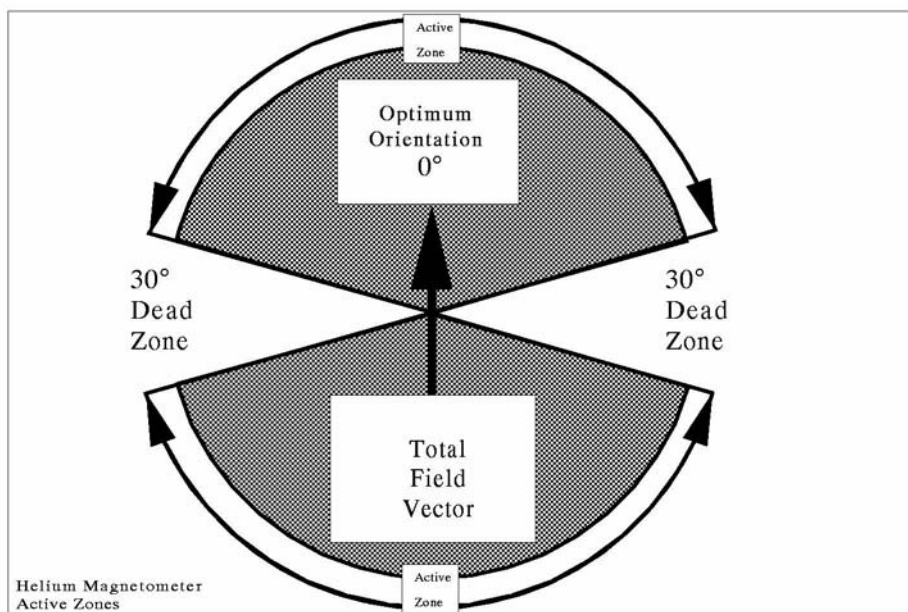

## APPENDIX E-1

### SPECIFICATIONS - GR900 DETECTOR INTERFACE CONSOLE

PMT Capacity:	A maximum of 12 downward-looking and 3 upward-looking photomultiplier tubes (PMT) may be accommodated.
H. V. Power Supply	Common supply of 1400 V for all PMT anodes with an individual PMT cathode adjustment range from 0 to +400 volts.
Gain Range:	Adjustable over 16/1 range by varying PMT cathode voltage.
Resolution:	The PMT gain can be adjusted and reset to within +/- 0.2%, i.e. the resolution of the gain control is +/- 0.2 volts.
Output Current:	250 microamps @ 1400 volts max. available for each PMT.
PMT Regulation:	Each PMT voltage is stable to +/- 0.01%.
Operating Temperature:	0°C to +50°C ambient.
Mixer Amplifiers:	Input capability up to 12 PMT's, or 3072 cu. in. (50.4 l) downward-looking and 3 PMT's or 768 cu. in. (12.6 l) upward-looking.
Mixer Gain:	Input equals output (gain = 1). With a 95 ohm load. 0.5 volt = 1 MeV. 5.0 volt max. output into 95 ohm load.
Temperature Control:	+20°C to +60°C internal DET package temperature in 10°C steps.
Temperature Regulation:	+/- 1°C for ambient temperature range from -20°C to +45°C.
Power Requirements:	Console: +/- 15 V, 100 mA Xtal Heater: 28 V, 0.75 amp/Xtal  Note: Additional +/- 20 mA required for each PMT
Console Size and Weight:	3.5" high x 19" wide x 15" deep (8.9 x 48.3 x 38 cm) 17.5 lbs. (7.9 kg)

## APPENDIX E-2

### SPECIFICATIONS - DET1024 SPECTROMETER CRYSTAL DETECTOR

Crystal Type:	NaI - slab form - 4" thick x 16" wide x 16" long
Volume:	1024 cu. in. (16,780 cu. cm.)
System Resolution:	Equal to or less than 10% FWHM at 662 KeV. Held within 0.5% of starting value over 12 hours of continuous operation.
Peak Shift:	Held within +/- 1% over 12 hours of continuous operation. Split window peak setting by front panel meter.
Gain Controls:	Individual controls for each PMT on Detector Interface (see GR-900 Detector Interface specification)
High Voltage Power Supply	1200V DC held within +/- 1% over 24 hours of continuous operation. (Supplied by GR-900)
Temperature:	Operating: Internal temperature automatically regulated to +/- 1°C over the range +10°C to +50°C by the GR-900.  Storage: -20°C to +65°C
Power:	22 to 32V DC. 20 watts average, 150 watts peak (supplied by GR-900). Provision for separate standby overnight power supply.
Dimensions and Weight:	Crystal Detector package -  7-1/8 x 21-1/8 x 25 1/4 inches - 170 lbs.

## APPENDIX E-3

### SPECIFICATIONS - NORLAND IT-5410 ANALOG-TO-DIGITAL CONVERTER

#### A. ADC INPUT

Polarity:	0-10V unipolar or positive first bipolar
Full scale input:	8 volts
Rise time:	0.1 to 10 microseconds
Fall time:	0.1 to 10 microseconds
Impedance:	1 K ohm
Duration:	0.5 microseconds minimum
Coupling:	DC (BLR OFF) or AC (BLR ON)

#### B. PERFORMANCE

Conversion Clock Rate:

50 MHz (IT-5410/50), 8192 channel resolution

100 MHz (IT-5410/100), 8192 channel resolution

200 MHz (IT-5410/200), 8192 channel resolution

Conversion Time per event:

Signal rise time + 1.2 microseconds + Logic + (Y x N) nSec

where Y =

20 for 50 MHz
10 for 100 MHz
5 for 200 MHz

and N = channel number

ACD Linearity

1. Integral: +/- .075 over upper 99% of full scale range

2. Differential: +/- .075 over upper 99% of full scale range

ACD Stability

Long Term: Less than .01% zero level and conversion gain shift for 24 hour period at constant temperature and line voltage

Temperature: Less than .005% of full scale /°C

Peak Shift: Less than 0.04% of full scale for count rates up to 20 KHz

Channel Profile: Typically better than 90%

#### C. CONTROLS

Baseline Restorer (BLR):

Switchable AC passive

Coincidence (COINC):

Prompt (delayed jumper selectable)

ZERO:

0-100% range control

For selecting zero energy intercept level by 22 turn potentiometer

Lower Level:

10 turn potentiometer

Discriminator (LLD)

control for 0-100% discrimination of lower level input signal

## APPENDIX E-4

Upper Level: Discriminator (ULD)	22 turn potentiometer control for 5-125% discrimination of upper level input signal
GAIN:	Miniature LED indicators activated by momentary toggle switch selects conversion gain setting. Ranges available for 8 volt input signal are: 256, 512, 1024, 2048, 4096, 8192 channels.
OFFSET	Function: Offsets spectrum digitally by value indicated on miniature LED. Offsets are toggle selectable in 256 channel increments throughout the 8192 channel range.
Dead Time Meter:	Indicates % of dead time of ADC for converting an input pulse. Range is 0-100%
SCA:	Single channel analyzer output available on ADC rear panel. 50 pin connector and BNC connector and BNC connector on rear panel of IT-5400 mainframe.

### D. MECHANICAL

- 1) Single width NIM - standard configuration
- 2) 50 pin connector on rear panel provides all significant I/O signals.
- 3) Compatible with all NIM standard bins and power supplies per TID-20893 (Rev. 3) which provide = 6V output

# APPENDIX F. Aircraft Acquisition System

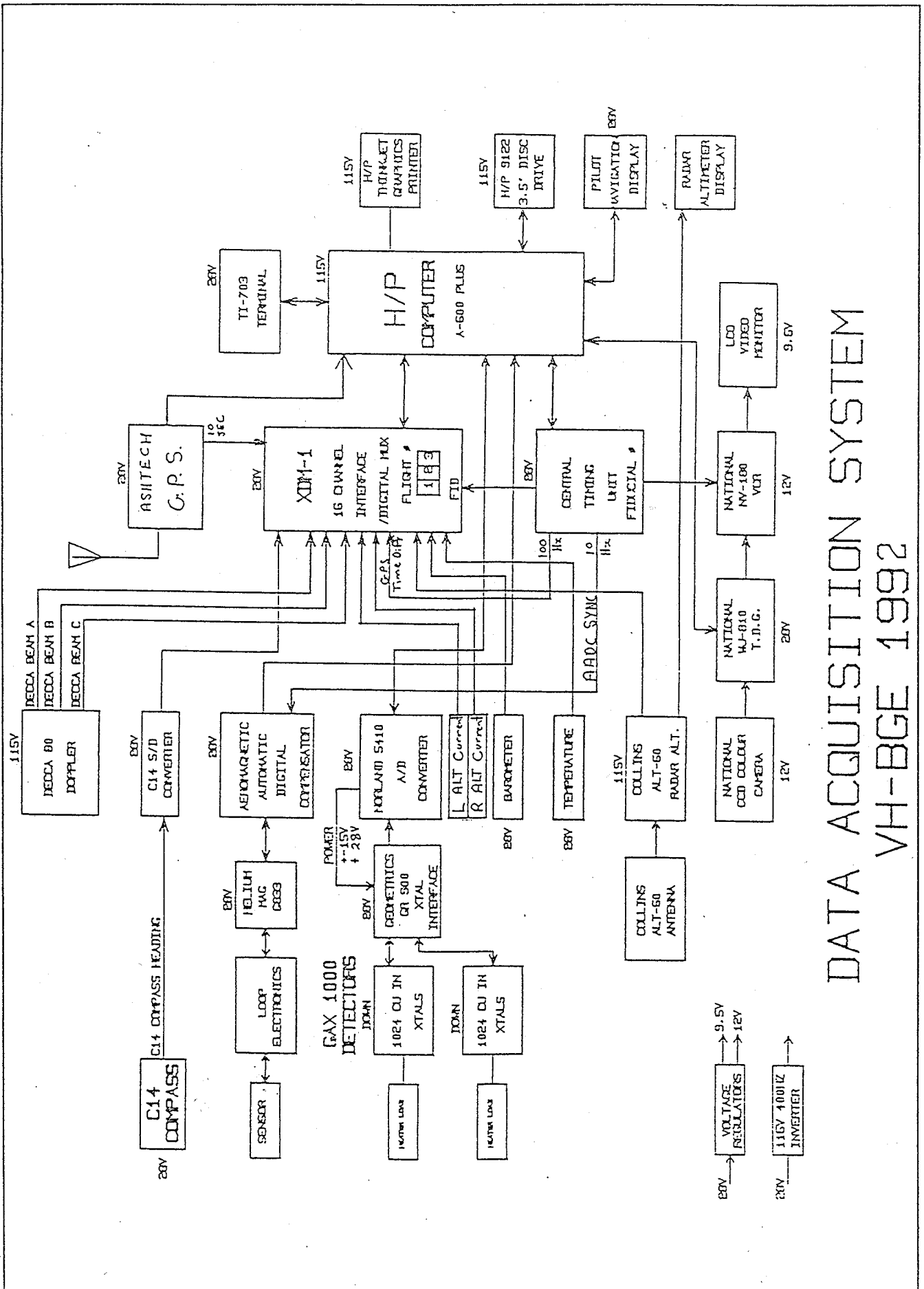

DATA ACQUISITION SYSTEM  
VH-BGE 1992

## APPENDIX G

### COMPENSATION RESULTS

COMPENSATION 1. DATE FLOWN: 28 February 1992  
DATES USED: 28 February - 10 March 1992

SDU = 0.5280  
SDC = 0.0545  
IR = 9.6  
VN = 8.8

COMPENSATION 2. DATE FLOWN: 12 March 1992  
DATES USED: 12 March - 12 April 1992

SDU = 0.5268  
SDC = 0.0496  
IR = 10.6  
VN = 7.1

COMPENSATION 3. DATE FLOWN: 16 April 1992  
DATES USED: 16 April - 25 April 1992

SDU = 0.5761  
SDC = 0.0459  
IR = 12.6  
VN = 11.7

SDU = Standard deviation of the data recorded during manoeuvres.

SDC = Standard deviation of the data recorded during manoeuvres after compensation corrections have been applied.

IR = Improvement ratio =  $SDU/SDC$

VN = Vector Norm, a measure of the degree of difficulty in calculating the coefficients.

APPENDIX H.  
Gamma-ray Spectrometer Test Line Location

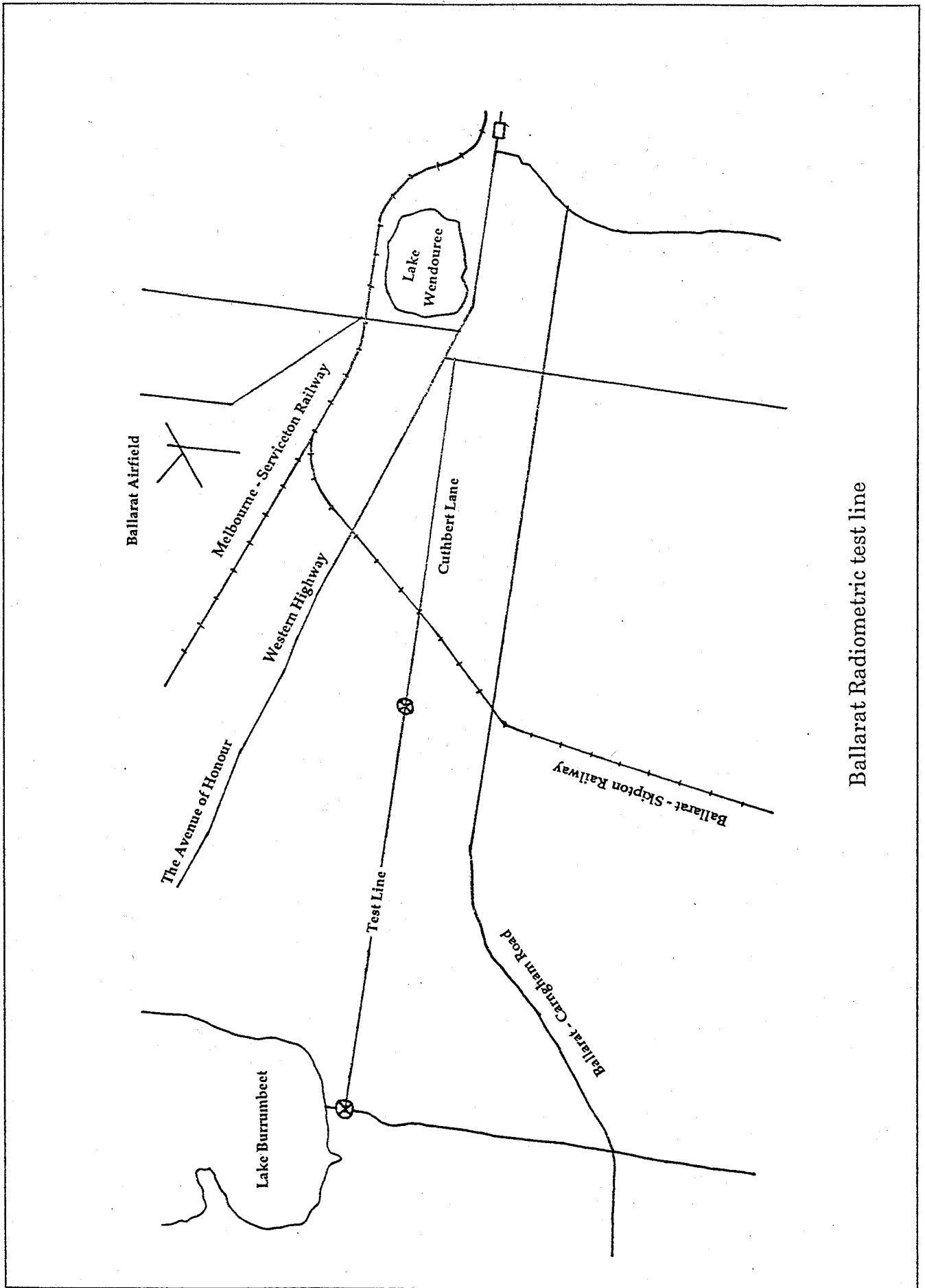

## APPENDIX I

### CORRECTIONS TO NAVIGATION DATA

#### (a) Position calculation delay correction

A correction due to the finite time taken for the GPS system to calculate a position and transfer the information to the acquisition system. This delay time is dependent on the number of satellites used to calculate the position. A delay of 0.6 seconds has been determined for a calculation using five satellites by flying clover leaf patterns over a reference point. This value is considered to be representative and was used for all delay corrections.

#### (b) Fiducial synchronisation correction

A correction due to the time lag between when a GPS position is available to the acquisition system and when the next fiducial is available to pair the position with.

#### (c) "Ranger" corrections

GPS base station data are used to calculate "Ranger" position corrections at five second intervals. These corrections are applied to the aircraft raw position data which are recorded every second.

Discontinuities (steps) sometimes occur in raw GPS data. These are also manifested as steps in the correction set.

When such steps in the raw GPS data occur between successive correction values, the corrections are linearly interpolated to the step boundary using corrections from the appropriate side of the step.

If multiple steps in the raw GPS data occur between successive correction values it is impossible to interpolate corrections over this interval, in which case the intervening GPS data are set to undefined.

#### (d) Low pass filter

The problem described in (c) can lead to small steps in the data where the original steps were too small to detect so were not corrected. A low pass 11 point convolution filter with a cut-off wavelength of 300 m was passed over the data.

#### (e) Coordinate system conversion

GPS data were converted from the WGS 84 geodetic coordinate system to the AGD 66 geodetic coordinate system.

#### (f). Reference navigation data to position of magnetometer sensor

The calculated GPS positions refer to the position of the GPS receiver's antenna. Since the magnetometer is the most position sensitive instrument, all position data is shifted 11.4 meters toward the rear of the aircraft to correspond with the position of the magnetometer's sensor.

#### (g) Doppler infill of gaps

Whenever gaps (<10 km) in the GPS data occurred they were infilled with data generated from the doppler navigation system. Gaps in the GPS data greater than ten kilometres were re flown.

# APPENDIX J-1

## AGSO ARCHIVE DATA, GRID AND MAGNETIC TAPE FORMAT FOR AIRBORNE GEOPHYSICAL DATA

### CONTENTS

#### 1. THE AGSO SEQUENTIAL FILE STRUCTURE

##### 1.1 INTRODUCTION

##### 1.2 GENERAL FILE STRUCTURE

##### 1.3 CHANNELS AND SAMPLES

##### 1.4 SEGMENT DIRECTORY RECORD

##### 1.5 DATA RECORD

##### 1.6 NO DATA VALUE

##### 1.7 STANDARD DATA CHANNELS

#### 2. PHYSICAL FORMAT FOR MAGNETIC TAPES

##### 2.1 GENERAL

##### 2.2 PHYSICAL PARAMETERS OF TAPE

##### 2.3 TAPE STRUCTURE

##### 2.4 PHYSICAL RECORDS AND BLOCKS

#### 3. GRID FILE FORMAT

##### 3.1 HEADER RECORD

##### 3.2 DATA RECORDS

TABLES

FIGURES

## APPENDIX J-2

### 1. THE AGSO SEQUENTIAL FILE STRUCTURE

#### 1.1 INTRODUCTION

This appendix describes the general sequential file structure used by AGSO to store airborne geophysical data. For the purpose of this survey nine data chains are involved for each line and tie. They are:

- channel 4 edition 1 (processed navigation)
- channel 4 edition 2 (processed magnetics)
- channel 4 edition 3 (processed spectrometrics)
- channel 5 edition 1 (doppler)
- channel 6 edition 1 (raw spectrometrics)
- channel 8 edition 1 (raw magnetics)
- channel 10 edition 1 (multi-channel spectra)
- channel 14 edition 1 (pressure,temperature,cosmic data)
- channel 16 edition 1 (raw navigation)

#### 1.2 GENERAL FILE STRUCTURE

The information pertaining to each traverse (line or tie) is held on the file as a separate entity called a segment. Segments are separated from each other by industry standard EOF records. The end of the file is indicated by two or more consecutive EOF records. Each segment consists of two types of records. Both types are 5120 characters long.

1. Segment Directory Record (SDR) : the first record on each segment. It defines the data content of the segment.
2. Data Records (DAR's) : hold the measured data values.

The general structure is shown in Figure 1.

#### 1.3 CHANNELS AND SAMPLES

Data are recorded at regular intervals in time along a traverse. The data recorded at one instant of time are held as any ordered set or sub-set. Each set is held logically distinct and referred to as a channel. The data records in a segment hold all the information for one channel in the form of a data chain, then all the data for the next channel and so on for as many channels as the segment holds.

Each channel is uniquely defined by a channel number and an edition number. The measurement(s) taken for a channel at a given time is called a sample. Samples are held within each channel in increasing order of fiducial (time).

In defining channels the channel number can be used to define the sample format and the edition type of the data. For example, within AGSO, samples with format (longitude, latitude, value, value....) have a channel number of 4 with edition 2 for magnetics and edition 3 for radiometrics.

## APPENDIX J-3

### 1.4 SEGMENT DIRECTORY RECORD (SDR)

Lines and ties are uniquely identified as follows :

1. Project number: a unique number to identify the survey.
2. Group number : a unique number within a survey for each flight made. That is, several lines may be recorded on one flight (group). AGSO convention is for group numbers to lie between 001 and 999 inclusive.
3. Segment numbers : a unique number within a survey for a line or tie. AGSO convention is for ordinary line numbers to lie between 1000 and 9999 inclusive and tie line numbers between 100 and 999 inclusive.

The segment directory record identifies the data segment at Project, Group and Segment level and defines the data channels, their structure and the location of their data chains in the segment. Each SDR consists of one or more 10 word blocks. The first, the Segment Identification Block (SIB), identifies the segment and gives the number of data channels held in the segment.

For this survey the number of data channels is nine as mentioned in the introduction. Subsequent blocks, one for each data channel, define the data channels and their location within the segment. These are called Channel Identification Blocks (CIB's). A typical SDR is shown in Figure 1 and its exact format given in Table 1. All unused words in the SDR are set to zero.

The last word in the record in the past has been used as check sum and represents the sum of all the other words in the record. The check sum word is no longer used and is set to zero.

The overall record format is 2I9, 509I10, I12.

### 1.5 DATA RECORD (DAR)

These each contain 512 values. The first two are fiducials giving the fiducial range of the samples contained in the record. The next 508 represent data values, the second last is always zero (to maintain compatibility with our random access file format) and the last is a record check sum representing the sum of all other values in the record.

If a record is the last one in a data chain for a given channel all unused values are set to zero, with the next channel commencing at the start of the next data record. The N data records in a segment are numbered from 2 to N+1, the SDR being regarded as record one in a segment, with records for a given channel following each other sequentially. The data record addresses in the channel identification block of the SDR refer to this sequential numbering of the data records. A typical segment is shown in Figure 1 and the exact format of a data record given in Table 2.

The overall format of each data record is : 2I9, 509I10, I12.

### 1.6 NO DATA VALUE

For a variety of reasons it is sometimes necessary to flag a data value to indicate it is to be ignored. This is achieved by replacing the data word in question by the value 536870912. If a gap exists in a data chain each word of every sample involved must be replaced by 536870912, the so-called missing value. Thus a 1:1 correspondence is maintained between the fiducials encompassed by a data chain and its samples.

## APPENDIX J-4

### 1.7 STANDARD DATA CHANNELS

The standard AGSO data channels are :

channel 4 edition 1 (processed navigation)  
channel 4 edition 2 (processed magnetics)  
channel 4 edition 3 (processed spectrometrics)  
channel 5 edition 1 (doppler)  
channel 6 edition 1 (raw spectrometrics)  
channel 8 edition 1 (raw magnetics)  
channel 10 edition 1 (multi-channel spectra)  
channel 14 edition 1 (pressure,temperature,cosmic data)  
channel 16 edition 1 (raw navigation)

#### **C4 E1 - Navigation**

Channel number = 4  
Edition number = 1  
Sample size = 2 words  
word 1 = Longitude in degrees \* 1 000 000  
word 2 = Latitude in degrees \* 1 000 000

#### **C4 E2 - Total Magnetic Intensity**

Channel number = 4  
Edition number = 2  
Sample size = 4 words  
word 1 and word 2 as for C4 E1  
word 3 = final (not micro-levelled) TMI (nT) \* 1000  
word 4 = final micro-levelled TMI (nT) \*1000

#### **C4 E3 - Corrected spectrometer data**

Channel number = 4  
Edition number = 3  
Sample size = 7 words  
word 1 and word 2 as for C4 E1  
word 3 = final Total Count (counts/sec) \* 1000  
word 4 = final Potassium (counts/sec) \* 1000  
word 5 = final Uranium (counts/sec) \* 1000  
word 6 = final Thorium (counts/sec) \* 1000  
word 7 = Altitude in metres above ground level

#### **C5 E1 - Doppler navigation data**

Channel number = 5  
Edition number = 1  
Sample size = 2 words  
word 1 = doppler along track (km)  
word 2 = doppler across track (m)

#### **C6 E1 - Raw spectrometer data**

Channel number = 6  
Edition number = 1  
Sample size = 7 words

## APPENDIX J-5

word 1 = Total count (counts/sec) \* 1000  
word 2 = Potassium (counts/sec) \* 1000  
word 3 = Uranium (counts/sec) \* 1000  
word 4 = Thorium (counts/sec) \* 1000  
word 5 = Altitude in metres above ground level

### **C8 E1 - Raw Magnetics**

Channel number = 8  
Edition number = 1  
Sample size = 1 word  
word 1 = TMI \* 1000

### **C10 E1 - Multi-channel spectra**

Channel number = 10  
Edition number = 1  
Sample size = 290 words  
word 1 = start fiducial for spectra  
word 2 = integration time for spectra (seconds)  
word 3 - 34 = define energy range of spectra, fiducials etc.  
Some control words yet to be defined.  
word 35 = counts in channel 0 (\* 1000)  
word 36 = counts in channel 1 (\* 1000)  
word 290 = counts in channel 255 (\* 1000)

### **C14 E1 - Pressure and Temperature**

Channel number = 14  
Edition number = 1  
Sample size = 7 words  
word 1 = pressure in millibars \* 10  
word 2 = temperature in degrees celsius \* 10  
word 3 - 6 = no longer used  
word 7 = cosmic channel (counts) \* 1000

### **C16 E1 - Raw GPS data**

Channel number = 16  
Edition number = 1  
Sample size = 4 words  
word 1 = Longitude in degrees \* 1 000 000  
word 2 = Latitude in degrees \* 1 000 000  
word 3 = GPS time in seconds \* 1000. GPS time is recorded in seconds from midnight the previous Sunday  
word 4 = Lag time. Time difference between time when a position is calculated and time until the next fiducial is generated by the data acquisition system. (hundredths of a second )

## APPENDIX J-6

### 2. PHYSICAL FORMAT FOR MAGNETIC TAPES

#### 2.1 GENERAL

Each magnetic tape (MT) consists of a sequence of segments each segment consisting of one or more physical records. Segments are to be separated by one EOF markers. The end of all information on a tape must be flagged by two or more consecutive EOF markers. Industry standard EOF records apply. Records are to be fixed length and each block is to contain one record.

#### 2.2 PHYSICAL PARAMETERS OF TAPES

- a. Tapes are 12.7 mm (0.5 inch) wide, 9 track industry standard magnetic tapes.
- b. Each tape has an external label identifying the airborne survey, character code, recording density, date tape written and the reel number in the set.

#### 2.3 TAPE STRUCTURE

- a. 9 track
- b. Written in ASCII
- c. Recording density of 6250 bpi
- d. International Standards Organisation end-of-block markers (EOB)
- e. International Standards Organisation end-of-file markers (EOF)
- f. No multi-tape files
- g. Multi-file tapes can be expected. Files will not span tapes.
- h. Last file on each tape shall end with at least two EOF's.

#### 2.4 PHYSICAL RECORDS AND BLOCKS

- a. Fixed length records of 5120 characters
- b. One record per block

## APPENDIX J-7

### 3. GRID FILE FORMAT

#### 3.1 HEADER RECORD

The first record on the file defines the content of the grid, including:

- a. Origin in latitude and longitude.
- b. Grid cell size.
- c. Number of rows and columns in the grid.
- d. Storage mode, i.e. whether the data is stored row by row or column by column. In general the data is stored by row.
- e. The exact header record format is in Table 3.

#### 3.2 DATA RECORDS

Each data record contains 320 values in E16.10 format. No location data is held in the data records - the location of a grid point is determined by its sequence within the file. The data for the grid may be sequenced in row or column order (i.e. row by row or column by column respectively). Each row or column is written on consecutive records and begins at the start of a new record. If the rows/columns do not contain a multiple of 320 values the last record for each row/column is padded with zeros. Any point in the grid which is undefined is set to -9999.0.

In ROW mode , rows are sequenced from north to south and within each row values are ordered from west to east.

In COLUMN mode, columns are sequenced from west to east and within each column values are ordered from north to south.

## APPENDIX J-8

### TABLE 1

#### SEGMENT DIRECTORY RECORD FORMAT

##### 1. SEGMENT IDENTIFICATION BLOCK

<u>WORD</u>	<u>CONTENT AND USE</u>	<u>FORMAT</u>
1	PROJECT IDENTIFICATION	I9
2	GROUP IDENTIFICATION	I9
3	SEGMENT IDENTIFICATION	I10
4	NUMBER OF CHANNELS ON SEGMENT	I10
5	DATE CODE - YYMMDD	I10
6	FIDUCIAL FACTOR - (fiducial size in seconds)	I10
7	TIME OF DAY AT FIDUCIAL ZERO IN SECONDS	I10
8	BEARING IN DEGREES (0-359) MEASURED EAST OF NORTH	I10
9	ALTITUDE IN METRES ABOVE SEA LEVEL	I10
10	GROUND CLEARANCE IN METRES	I10

##### 2. CHANNEL IDENTIFICATION BLOCK (for the Nth channel)

<u>WORD</u>	<u>CONTENT AND USE</u>	<u>FORMAT</u>
1	CHANNEL CODE	I10
2	EDITION NUMBERS	I10
3	FIDUCIAL INTERVAL BETWEEN SAMPLES	I10
4	NUMBER OF DATA VALUES (WORDS) PER SAMPLE	I10
5	ADDRESS OF FIRST DATA RECORD FOR CHANNEL	I10
6	ADDRESS OF LAST SAMPLE IN DATA CHAIN	I10
7	FIDUCIAL OF FIRST SAMPLE IN DATA CHAIN	I10
8	FIDUCIAL OF LAST SAMPLE IN DATA CHAIN	I10
9	UNUSED - SET TO ZERO	I10
10	UNUSED - SET TO ZERO	I10

## APPENDIX J-9

### TABLE 2

#### DATA RECORD FORMAT

WORD	CONTENT AND USE	FORMAT
1	FIDUCIAL AT FIRST DATA SAMPLE IN RECORD	I9
2	FIDUCIAL AT LAST DATA SAMPLE IN RECORD	I9
3	FIRST WORD OF FIRST SAMPLE	I10
4	SECOND WORD OF FIRST SAMPLE	I10
.		
.		
.		
.		
.	FIRST WORD OF SECOND SAMPLE	I10
.	SECOND WORD OF SECOND SAMPLE	I10
.		
ETC		
511	ALWAYS UNUSED - SET TO ZERO	I10
512	ALWAYS UNUSED - SET TO ZERO	I12

NOTE:

1. A data sample can be of any length greater than zero.
2. Each record contains an integral number of samples. This may lead to several unused words at the end of the record which are set to zero.

i.e. If a sample is 7 words long 72 samples will fit in a data record and words 507-510 will be set to zero.

## APPENDIX J-10

### TABLE 3

#### GRID HEADER RECORD FORMAT

CHARACTER POSITION	FIELD LENGTH	FORTRAN FORMAT	CONTENT
1-60	60	6A10	Grid Identification
61-70	10	11A10	Facts defining data acquisition/processing
171-180	10	A10	x,y units defining grid . Usually degrees.
181-192	12	E12.6	x origin of surface. Bottom left hand corner.
193-204	12	E12.6	y origin of surface. Bottom left hand corner.
205-214	10	A10	Type of z data in grid (e.g. TMI).
215-216	2	A2	Blanks.
217-228	12	I12	Number of data records per column or row.
229-240	12	E12.6	Grid increment in the x direction
241-252	12	E12.6	Grid increment in the y direction
253-262	10	A10	Time when original surface created (hh.mm.ss).
263-286	24	2A10,A4	Filter used on original z data.
287-310	12	2E12.6	x,y co-ordinate of the bottom left hand corner of the grid. Same as x,y origin.
311-320	10	A10	Date of creation of surface (dd/mm/yy).
321-344	24	2A10,A4	Blanks.
345-368	12	2E12.6	x,y co-ordinate of top right hand corner of grid. NOTE: these values are too large by one grid increment for tapes created prior to 01/06/85.
369-373	4	I5	Number of rows in the grid.
374-378	5	I5	Number of columns in the grid.
379-382	4	A4	Blanks.
383-388	6	A6	Defines if the grid is stored in column mode (COLUMN) or row mode (ROW).
389-5120			Blank filled.

FIGURE 1

SEQUENTIAL DATA FILE STRUCTURE

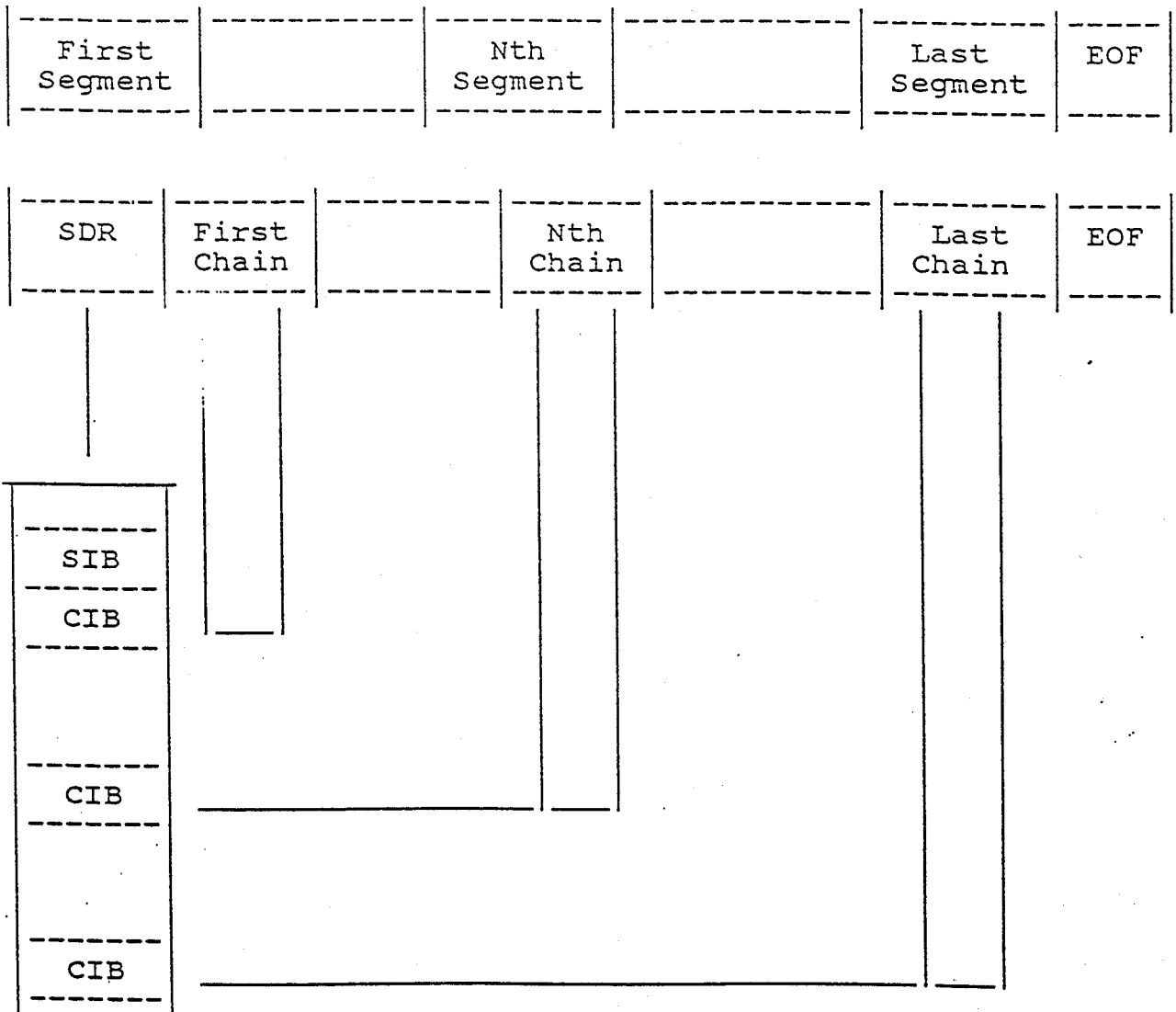

## APPENDIX K-1

### SPECIFICATIONS - RMS INSTRUMENTS AADC

INPUTS:	one or two high sensitivity magnetometers of optical absorption type.
INPUT FREQUENCY RANGE:	70 KHz - 350 KHz - Cs sensor 140 KHz - 700 KHz - K sensor 560 KHz - 2800 KHz - He sensor 850 Hz - 4260 Hz - Overhauser
MAGNETIC FIELD RANGE:	20,000 - 100,000 nT (gamma)
RESOLUTION:	1 pT (picotesla)
COMPENSATION PROCEDURE:	improvement ratio 10 - 20 typical for total field improvement ratio 20 - 100 typical for gradient
ACCURACY OF COMPENSATION:	0.035 nT (gamma) standard deviation for the entire aircraft flight envelope in the bandwidth 0 - 1 Hz typical
DATA OUTPUT RATE:	10 Hz
SYSTEM FREQUENCY RESPONSE:	0 - 0.9 Hz
INTERNAL SYSTEM NOISE:	less than 2 pT (standard deviation in the bandwidth 0 - 1 Hz)
DURATION OF CALIBRATION: FLIGHT MANOUEVRES	5 - 8 minutes typical
VECTOR MAGNETOMETER:	Develco Model 9202-02 (3-axis fluxgate)
MICROCOMPUTER:	SBC-11/21 Plus (DEC) Front End LSI-11/73 (DEC) Main CPU
KEYBOARD:	limited alphanumeric
DISPLAY:	green fluorescent, 80 character self scan panel

## APPENDIX K-2

OUTPUTS:	serial data communication port: RS232C - max. rate 19.2 KBaud
	parallel output port: 16 bit with full handshaking (DRV11-J) (optional)
	4 analog outputs of 12 bit resolution, 10 V full scale (optional)
POWER:	28 +/- 4 VDC, 5A, 150 W (for single magnetometer) 7A, 196 W (for gradiometer system)
ENVIRONMENTAL:	
OPERATING TEMPERATURE:	0 to 50 degrees C
STORAGE TEMPERATURE:	-20 to 55 degrees C
RELATIVE HUMIDITY:	0 - 99%, non-condensing
ALTITUDE:	0 - 6000 m (0 - 20,000 ft)
PHYSICAL DATA:	console dimensions: 483 x 178 x 440 mm (19 x 7 x 17.3 in)
	console weight: 12.5 kg (28 lbs)
	power supply dimensions: 225 x 180 x 220 mm (8.9 x 7.25 x 8.7 in)
	power supply weight: 5.5 kg (12 lbs)

## APPENDIX L-1

### SPECIFICATIONS - G866 BASE STATION MAGNETOMETER

Display: Six-digit, seven segment, numeric display of magnetic field with 0.1 gamma resolution. Same display used to set or view time-of-day and date, signal strength, battery voltage, and variables.

Resolution: Varies from 0.1 to 1 gamma depending on sample interval. 1 gamma for 0.5 to 0.9 second, 0.5 gamma for 1.0 to 1.7 seconds, 0.2 gamma for 1.4 to 2.9 seconds, and 0.1 gamma for 3.0 or more seconds.

Accuracy: one-half gamma.

Controls: Pressure-sensitive keyboard to control operation and to select variables. All control clock settings are stored in non-volatile memory, powered by lithium battery.

Clock: Julian clock with stability of 5 seconds per month at room temperature and 5 seconds per day over a temperature range of -20 to +50 degrees celsius.

Tuning: Push-button tuning from keyboard. Current tuning value displayed on request. Tuning range is 20 to 90 kilogammas.

Gradient Tolerance: Tolerates gradients to 5000 gammas/meter. When high gradients reduce signal quality, a partial reading is maintained at a resolution consistent with implied accuracy.

Sample Interval: Push-button selection of sample interval from 0.5 to 999.9 seconds. Resolution of 0.1 seconds.

Manual Read: Readings may be initiated by a front panel push-button.

External Cycling: Can be initiated by external cycling device.

Recorder: Electrosensitive recorder producing permanent records insensitive to heat, cold, sunlight or age. Chart width approximately 10 cm with the following formats available.

Narrow: Approximately one half of chart is an analog representation of every reading formed from closely connected dots in two overlapping scales. Remainder of chart is a numerical listing of periodic reading (e.g., every ninth reading) and time.

Wide Analog: The printed table may be deleted and the analog scale expanded when a high resolution analog chart is the preferred format (e.g., in magnetic search).

Variable "Chart Speed": Simulates changes in chart speed by varying time-axis spaces between plotted readings.

Recorder Scale: Four, push-button selected scales of 10/100, 20/200, 50/500 or 100/1000 gammas full scale. The analog records are dual range, as though there were two overlapping pens recording at different scale factors. The scales overlap by 20% with hysteresis so that there is no jitter at the scale edges.

## APPENDIX L-2

Event Mark: A front panel push button or external input will cause an extra mark to be added for identification of special events.

Paper Feed: Advances paper rapidly for loading and unloading paper. Also causes the printer to annotate the record with sensitivity, scale factors, sample interval and date.

Special Functions: Internal switch, accessible by hinging up the front panel, allows selection of variations in operation:

- a) Vary "chart speed" (see recorder).
- b) Narrow chart (see recorder).
- c) Wide analog chart (see recorder).
- d) Power conservation. Display will automatically shut off 7 seconds after a reading has been taken, or two minutes after a key has been depressed.
- e) 3-point running average (smooths data by taking running average).
- f) 5-point running average (smooths data by taking running average).
- g) 7-point running average (smooths data by taking running average).
- h) Control disable (disable all front panel controls which might be used to modify the stored parameters, prevents operator errors), saves power.

Outputs: (1) BCD character serial output of time, day and field readings for use with external digital recorder. (Also outputs suitable handshaking signals for interfacing.) and (2) RS-232-C compatible ASCII output of time, day, and field reading: followed by a carriage return and line feed at three selectable baud rates (110, 300, 9600). This output is for an external printer or computer-based acquisition system.

## APPENDIX M

NAME	TYPE	CONTOUR INTERVAL /VERTICAL SCALE	REFERENCE NUMBER
1:250 000			
Ballarat	TMI Contours	10 nT	22-1/J54-8/1
"	TC Contours	50 cps	22-1/J54-8/2
1:100 000			
Beaufort	TMI Contours	5 nT	22-2/J54-8/1-2
"	TC Contours	50 cps	22-2/J54-8/2-2
"	Flight Path		22-2/J54-8/3-2
"	TMI Profiles	700 nT/cm	22-2/J54-8/4-2
"	TC Profiles	2500 cps/cm	22-2/J54-8/6-2
Creswick	TMI Contours	5 nT	22-2/J54-8/1-3
"	TC Contours	50 cps	22-2/J54-8/2-3
"	Flight Path		22-2/J54-8/3-3
"	TMI Profiles	800 nT/cm	22-2/J54-8/4-3
"	TC Profiles	2500 cps/cm	22-2/J54-8/6-3
Willaura	TMI Contours	5 nT	22-2/J54-8/1-4
"	TC Contours	50 cps	22-2/J54-8/2-4
"	Flight Path		22-2/J54-8/3-4
"	TMI Profiles	800 nT/cm	22-2/J54-8/4-4
"	TC Profiles	2500 cps/cm	22-2/J54-8/6-4
Skipton	TMI Contours	5 nT	22-2/J54-8/1-5
"	TC Contours	50 cps	22-2/J54-8/2-5
"	Flight Path		22-2/J54-8/3-5
"	TMI Profiles	800 nT/cm	22-2/J54-8/4-5
"	TC Profiles	2500 cps/cm	22-2/J54-8/6-5
Ballarat	TMI Contours	5 nT	22-2/J54-8/1-6
"	TC Contours	50 cps	22-2/J54-8/2-6
"	Flight Path		22-2/J54-8/3-6
"	TMI Profiles	800 nT/cm	22-2/J54-8/4-6
"	TC Profiles	2500 cps/cm	22-2/J54-8/6-6
1:50 000			
Chatsworth	TMI Contours	2 nT	22-3/J54-8/1-4/3
"	TC Contours	20 cps	22-3/J54-8/2-4/3
"	Flight Path		22-3/J54-8/3-4/3
"	TMI Profiles	500 nT/cm	22-3/J54-8/4-4/3
"	TC Profiles	2500 cps/cm	22-3/J54-8/6-4/3
Willaura	TMI Contours	2 nT	22-3/J54-8/1-4/4
"	TC Contours	20 cps	22-3/J54-8/2-4/4
"	Flight Path		22-3/J54-8/3-4/4
"	TMI Profiles	500 nT/cm	22-3/J54-8/4-4/4
"	TC Profiles	2500 cps/cm	22-3/J54-8/6-4/4