

**Technical Report 9
Mt Stromlo Satellite Laser
Ranging Observatory
Local Tie Survey
February 2002**



**Gary Johnston and Paul Digney
National Mapping Division,
Geoscience Australia**

1. Background

The local tie survey at the Mt Stromlo Satellite Laser Ranging (SLR) station was initially performed in June 1999. This survey was completed for the purpose of determining the connection between the SLR reference point and the GPS reference point. It also determined the relationship between the SLR reference point (the telescope invariant point), the four SLR calibration pillars and the surrounding survey monuments. Monuments connected to include the fundamental survey pillar (AU045), the west pillar (AU054), Mt Stromlo Trig and benchmark SR1526. The results from this survey can be found in AUSLIG Technical Report Number 3 at <http://www.auslig.gov.au/geodesy/techrpts/pdf/techrep3>

In late 2001 the telescope elevation axis bearings were replaced. This required a resurvey of the telescope IVP. Therefore a repeat of the 1999 survey was completed in February 2002. Mt Stromlo Trig was not connected and SR1526 was only connected in height.

As in 1999, the Space Geodesy Analysis Centre (SGAC) of Geoscience Australia's National Mapping Division, processed the results from the survey to determine the intersection of axes of rotation of the SLR telescope, which is the telescope invariant point (IVP).

2. Observations

A Leica TC2003 Total Station was used for all horizontal angles, slope distances and zenith angles. Where zenith angles were used for heighting, the Rueger method was used to determine the height of the trunnion axis of the total station above the station mark. Simplistically, the Rueger method consists of observing a levelling staff over a known point with the vertical circle of the total station set to 90 degrees (horizontal). Using the known height differences of the two survey marks and the observed staff reading a height of instrument can be easily and accurately derived.

Orthometric height was transferred through the control network using the Total Station differential levelling technique (Johnston, 2002). The levelling results in combination with AUSGeoid98 (Johnston, 1998) were used to transfer ellipsoidal height from AU045 through the network.

The coordinates of the telescopes invariant point (IVP) were determined from the two independent sets of observations described below, rotating the telescope about its horizontal axis and then about its vertical axis.

Observations were taken to the SLR telescope with it set at a variety of horizontal and vertical positions. Four targets were placed on the telescope for the determination of the horizontal axis of rotation (see Figure 1). Two prisms were mounted on the top of the telescope stanchions. Another two retro reflecting tape targets were mounted on the telescope, which was then locked in the zenith position. Observations were taken from AU045 to all four targets with the telescope set at twenty-degree increments in azimuth (0, 20, 40, etc.) for a full 360 degrees. A second set of observations was taken to the same four targets from AU054 with the telescope again rotated through 360 degrees. A third set of observation was taken from North Pillar (AU052) to the same

four targets. The telescope was again rotated through 360 degrees with observation taken every 20 degrees.

For the elevation axis of rotation three Retro-reflector tape targets were positioned on the telescope (see Figure 1). Observations were taken from AU045 to each of these targets at a ten-degree interval of vertical rotation of the telescope. The horizontal direction of the telescope was locked perpendicular to the line of sight. A second set of observations was taken from AU054 with the telescope now pointed 180 degrees to the first set to another three targets. This perpendicular setting was achieved by lining the two stanchion targets up with the line of sight.

AU052 (STR1) (see Figure 2) has a Rogue GPS receiver (and AOA Dorne Margolin T antenna) operating on it (see STR1.log at ftp://ftp.auslig.gov.au/igs/station_logs/). A second GPS set consisting of a Javad Legacy and Javad Regency antenna (<ftp://ftp.auslig.gov.au/igex/station/>) was operating on the fundamental survey pillar (AU045) as part of the International Glonass Service. This data was processed with data from AU017 (TIDB) (see processing report in Appendix 1). These baselines provide the datum and orientation for the network. The comparison of the GPS vector between AU045 and AU052 disagrees with the terrestrial observations by several millimetres. A far better agreement was obtained by the GPS baseline observed in 1999 before the placement of the Javad equipment. This indicates that some mis-modelling of the Javad Regant antenna phase centre pattern may still be present. As such the GPS baseline was given a lower weight in the adjustment so as not to distort the terrestrial observations.

On the 4th April 2002 additional observation were taken to the vertical axis targets from AU045 in order to resolve some ambiguity in the instrument height at AU045 during the previous observations.

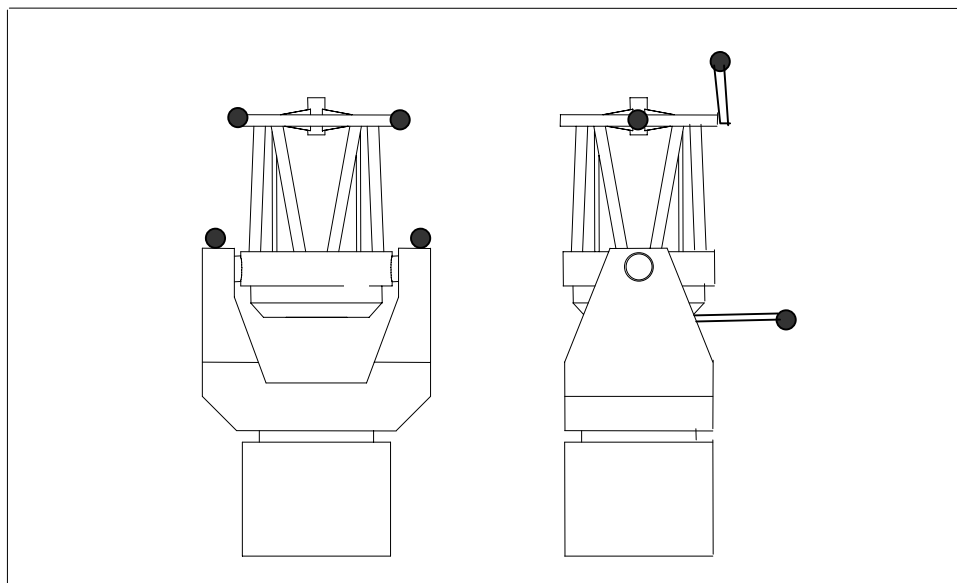

Figure1 Position of the targets for the2002 re-survey.

3. Reductions

All angular and distance observations were reduced to a grand mean per set and reformatted to the standard GEOLAB format. All distances were reduced for atmospheric (first and second velocity corrections) using the model supplied in the “Supplement to TC2002/T3000 Operator’s Manual” as follows:

$$\Delta D_1 = 281.8 \left[\frac{0.29065 p}{(1 + \alpha t)} - \frac{4.126 \cdot 10^{-4} \cdot h}{(1 + \alpha t)} \cdot 10^x \right]$$

Where

$$\begin{aligned} \Delta D_1 &= \text{Atmospheric correction in ppm} \\ p &= \text{Atmospheric pressure (mb)} \\ t &= \text{Ambient temperature (}^\circ\text{C)} \\ h &= \text{Relative humidity (\%)} \\ \alpha &= 1/273.16 \\ x &= \frac{7.5t}{237.3 + t} + 0.7857 \end{aligned}$$

They were also reduced for prism offsets, which in the case of the Leica precision prism is 0.000m. The tape retro-reflector has a prism offset of +0.0344m.

The GPS observations were formatted into a GEOLAB format and adjusted with the terrestrial observations. The resulting Cartesian positions for each of the targets was subsequently used by the SGAC to determine the centre of rotation of each of the axes and the point of intersection of the horizontal and vertical axis (IVP).

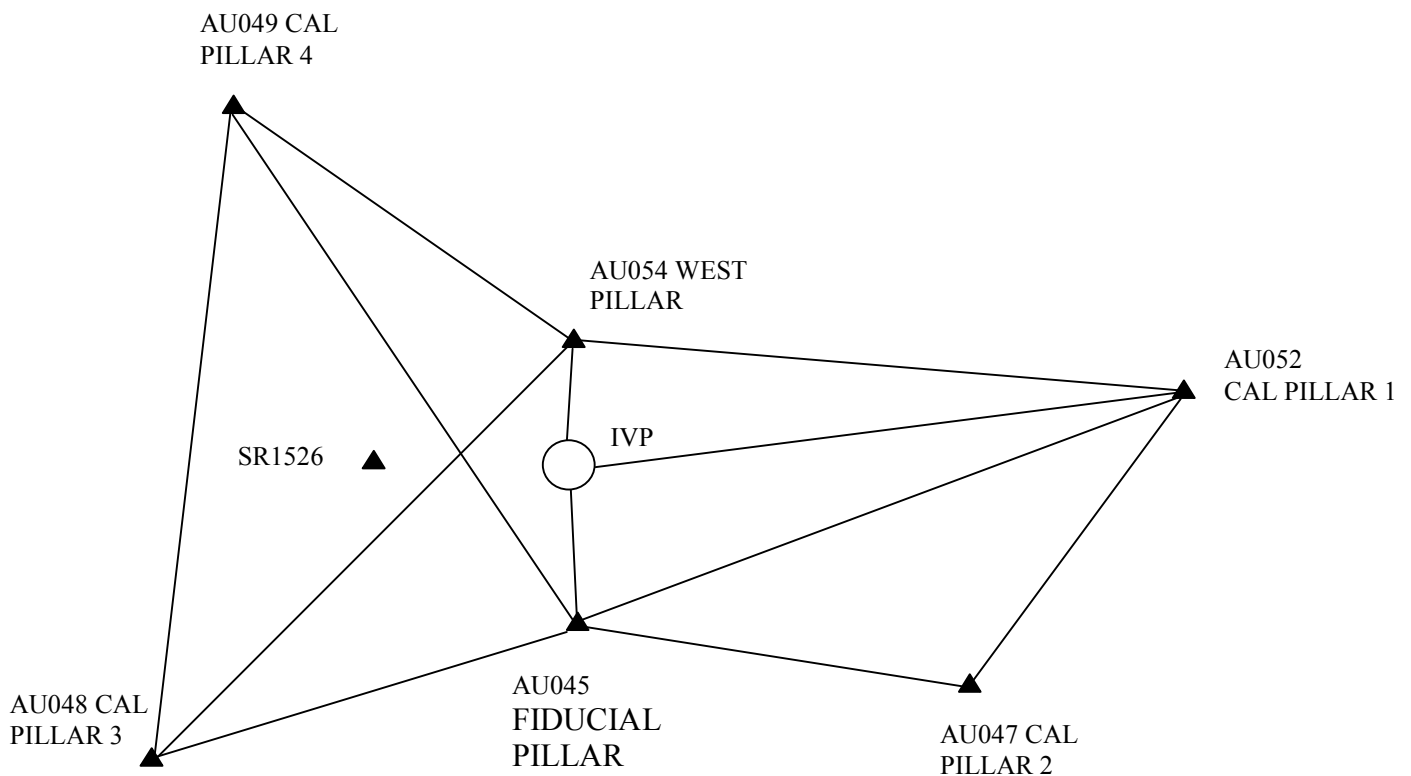

Figure 2. Stromlo local tie survey network

4. Mark Descriptions

AU045 (STRO): Domes 50119M001. The intersection of the top of the stainless steel pillar plate with the vertical axis of a 5/8" ϕ Whitworth threaded stainless steel spigot. This pillar plate is set into the top of the fundamental survey pillar at the Stromlo Satellite Laser Ranging station. The Stainless steel pillar plate is inscribed with "AU045 Fundamental Pillar".

AU046: The intersection of the top of the stainless steel pillar plate with the vertical axis of a 5/8" ϕ Whitworth threaded stainless steel spigot. This pillar plate is fixed on top of North Calibration Pillar 1. The Stainless steel pillar plate is inscribed with "AU046". This mark is 0.183m below AU052 (STRO).

AU047: The intersection of the top of the stainless steel pillar plate with the vertical axis of a 5/8" ϕ Whitworth threaded stainless steel spigot. This pillar plate is fixed on top of Calibration Pillar 2. The Stainless steel pillar plate is inscribed with "AU047".

AU048: The intersection of the top of the stainless steel pillar plate with the vertical axis of a 5/8" ϕ Whitworth threaded stainless steel spigot. This pillar plate is fixed on top of Calibration Pillar 3. The Stainless steel pillar plate is inscribed with "AU048".

AU049: The intersection of the top of the stainless steel pillar plate with the vertical axis of a 5/8" ϕ Whitworth threaded stainless steel spigot. This pillar plate is fixed on top of Calibration Pillar 4. The Stainless steel pillar plate is inscribed with "AU049".

AU050: The intersection of the top of the stainless steel pillar plate with the vertical axis of a 5/8" ϕ Whitworth threaded stainless steel spigot. This mounting is on top of the north equipment pole protruding from the roof of the observatory.

AU051: The intersection of the top of the stainless steel pillar plate with the vertical axis of a 5/8" ϕ Whitworth threaded stainless steel spigot. This mounting is on top of the south equipment pole protruding from the roof of the observatory. The DORIS antenna is mounted directly above this point.

AU052: Domes 50119M002. The intersection of the top of the stainless steel pillar plate with the vertical axis of a 5/8" ϕ Whitworth threaded stainless steel spigot. The Stainless steel pillar plate is inscribed with "AU052". This pillar plate is bolted on top of the north calibration pillar at the Stromlo Satellite Laser Ranging station, and is 183 mm vertically above a similar mounting which is used for the Laser calibration target. This mounting for the calibration target is known as AU046. For reference in GPS processing, AU052 has the 4-character ID STRO.

AU054: The intersection of the top of the brass pillar plate 0.15m ϕ with the vertical axis of a 5/8" ϕ Whitworth threaded brass spigot. This pillar plate is set into the top of 0.3m ϕ concrete pillar, which is 1.28m high. The Pillar is located to the west of the observatory.

IVP Stromlo SLR: Domes 50119S001. The intersection of the azimuth axis and elevation axis of rotation of the Mt Stromlo Satellite Laser Ranging telescope.

DORIS (MSOB): Domes 50119S002. The intersection of the vertical axis of the DORIS antenna with the plane coinciding with the reference height line marked on the DORIS antenna. The Doris antenna is mounted on a steel stanchion on the roof of the Stromlo SLR observatory.

SR1526: Levelling benchmark at south-west end of the observatory. It consists of a stainless steel rod with a centre punch mark at the top. The mark is under a steel cover plate.

TRIG: is the original Stromlo geodetic survey mark. It is a .303 cartridge case set in concrete, beneath a steel quadrapod.

AU017, DOMES 50103M108, is the GPS pillar at the Canberra Deep Space Communications Complex at Tidbinbilla. It is a small drill hole in the centre of the top of a stainless steel pillar plate that is set in the top of a 0.6 metre diameter reinforced concrete pillar. This pillar is set into the ground to a depth of 2.5 metres and protrudes 0.5 metres above ground level. The pillar plate bears the inscription: "TIDBINBILLA SPC-40 GPS STATION MARK JPL 4002-S 1992". The pillar is in the centre of a 6 metre square post & rail fence enclosure. The hardwood posts are 200 x 100 mm and the rails 150 x 25 mm. This fence does not obstruct the visibility horizon above 10 degrees elevation.

5. Results

STATION	Latitude				Longitude				Ellip HT (m)	STD LAT (m)	STD LONG (m)	STD HT (m)
	S	35	23	57.14163	E	148	58	47.9922				
AU017	S	35	23	57.14163	E	148	58	47.9922	665.3661	0.0006	0.0005	0.0024
AU045	S	35	18	58.18463	E	149	0	36.55523	802.5077	0.0001	0.0001	0.0001
AU046	S	35	18	55.92511	E	149	0	36.18743	799.7769	0.0002	0.0005	0.0005
AU047	S	35	18	57.47533	E	149	0	37.57221	807.1974	0.0003	0.0003	0.0005
AU048	S	35	19	1.06007	E	149	0	38.50881	801.5723	0.0005	0.0007	0.0005
AU049	S	35	18	59.15872	E	149	0	33.8861	794.5371	0.0005	0.0003	0.0005
AU050	S	35	18	57.73246	E	149	0	35.88141	802.7561	0.0003	0.0004	0.0002
AU051	S	35	18	58.00101	E	149	0	35.80756	802.7519	0.0002	0.0004	0.0002
AU052	S	35	18	55.9251	E	149	0	36.18744	799.9590	0.0001	0.0003	0.0003
AU054	S	35	18	57.90375	E	149	0	34.83436	798.7429	0.0002	0.0002	0.0005
IVP	S	35	18	58.11959	E	149	0	35.56768	804.0578	0.0012	0.0008	0.0008
DORIS	S	35	18	58.00094	E	149	0	35.80757	803.3859	0.0002	0.0004	0.0002

Table 1. Geodetic Latitude, Longitude and Ellipsoidal height and the associated standard deviations of the network stations. ITRF2000 @ 2000.0 co-ordinates and GRS80 ellipsoid adopted at AU017 (TIDB).

Station	X (m)	Y (m)	Z (m)	STD X (m)	STD Y (m)	STD Z (m)
AU017	-4460996.3453	2682557.0760	-3674443.4636	0.0018	0.0011	0.0014
AU045	-4467074.6280	2683011.8430	-3667007.8780	0.0001	0.0001	0.0001
AU046	-4467102.4468	2683039.3906	-3666949.4715	0.0004	0.0005	0.0003
AU047	-4467101.9713	2682998.2958	-3666992.7500	0.0003	0.0003	0.0004
AU048	-4467055.4629	2682942.7616	-3667079.6547	0.0007	0.0005	0.0005
AU049	-4467019.4545	2683057.3628	-3667027.7686	0.0003	0.0004	0.0005
AU050	-4467072.9437	2683030.6887	-3666996.6493	0.0002	0.0004	0.0003
AU051	-4467067.8783	2683029.8226	-3667003.4009	0.0002	0.0004	0.0002
AU052	-4467102.5743	2683039.4670	-3666949.5766	0.0003	0.0003	0.0002
AU054	-4467053.9003	2683050.1071	-3666998.6373	0.0004	0.0003	0.0003
IVP	-4467063.8601	2683034.4783	-3667007.1383	0.0009	0.0008	0.0010
DORIS	-4467068.3228	2683030.0895	-3667003.7657	0.0002	0.0004	0.0002

Table 2. Earth Centred Cartesian co-ordinates and the associated standard deviations of the network stations. ITRF2000 @ 2000.00 co-ordinates and GRS80 ellipsoid adopted at AU017 (TIDB).

From	To	MAJ-SEMI (m)	MED-SEMI (m)	MINI-SEMI (m)	DISTANCE (m)	MAJ-SEMI (AZ,VANG)	MED-SEMI (AZ,VANG)	MINI-SEMI (AZ,VANG)
IVP	AU017	0.0070	0.0037	0.0025	9609.4528	(0, 90)	(0, 0)	(90, 0)
IVP	AU045	0.0033	0.0021	0.0021	25.0769	(0, 0)	(90, 0)	(0, 90)
IVP	AU046	0.0033	0.0025	0.0024	69.5595	(0, 0)	(90, 0)	(0, 90)
IVP	AU047	0.0033	0.0024	0.0022	54.4854	(0, 0)	(0, 90)	(90, 0)
IVP	AU048	0.0035	0.0029	0.0024	117.2225	(0, 0)	(90, 0)	(0, 90)
IVP	AU049	0.0035	0.0024	0.0023	54.0478	(0, 0)	(0, 90)	(90, 0)
IVP	AU050	0.0034	0.0023	0.0021	14.3837	(0, 0)	(90, 0)	(0, 90)
IVP	AU051	0.0033	0.0024	0.0021	7.1965	(0, 0)	(90, 0)	(0, 90)
IVP	AU052	0.0033	0.0022	0.0022	69.5487	(0, 0)	(90, 0)	(0, 90)
IVP	AU054	0.0033	0.0024	0.0022	20.3893	(0, 0)	(0, 90)	(90, 0)
IVP	DORIS	0.0033	0.0024	0.0021	7.1283	(0, 0)	(90, 0)	(0, 90)

Table 3. Line Error ellipses between the Mt Stromlo IVP and all other network stations at Mt Stromlo, including AU017 (TIDB). Error ellipses are at the 95% confidence level.

The EOS retro-reflectors used for SLR calibration are positioned on AU046, AU047, AU048 and AU049. Table 4 lists to offsets for these prisms as determined by survey. In tables 5 and 6 the effective point of reflection of these prisms is referred to as AU046R etc. (See Appendix 3 for a description of the effective point of reflection)

Target	Height (m) above the pillar plate	Prisms offset (m) from the vertical axes of the spigot
AU046R	0.1014	0.0187
AU047R	0.1049	0.0188
AU048R	0.1018	0.0185
AU049R	0.1018	0.0179

Table 4. Height and horizontal offsets of the four EOS retro-reflectors from the pillar reference points.

SITE	X	Y	Z	DIFF X	DIFF Y	DIFF Z	RANGE (M)
IVP	-4467063.8601	2683034.4783	-3667007.1383	0.0	0.0	0.0	
AU046R	-4467102.5065	2683039.4314	-3666949.5450	-38.6464	4.9531	57.5933	69.5346
AU047R	-4467102.0323	2682998.3528	-3666992.8162	-38.1722	-36.1255	14.3221	54.4728
AU048R	-4467055.5352	2682942.8187	-3667079.7019	8.3249	-91.6596	-72.5636	117.2018
AU049R	-4467019.5384	2683057.3965	-3667027.8187	44.3217	22.9182	-20.6804	54.0124

Table 5. Earth Centred Cartesian co-ordinates for the point of reflection of the EOS Retro-reflectors on AU046, 47, 48 and 49. Differences from the IVP to each are also listed with the range.

Site	East (m)	North (m)	Up (m)	Distance (m)
AU046R	15.6526	67.6209	-4.1798	69.5346
	<i>15.6539</i>	<i>67.6203</i>	<i>-4.1764</i>	<i>69.5341</i>
AU047R	50.6233	19.8506	3.2443	54.4728
	<i>50.6245</i>	<i>19.8512</i>	<i>3.2434</i>	<i>54.4741</i>
AU048R	74.2893	-90.6182	-2.3848	117.2018
	<i>74.2870</i>	<i>-90.6200</i>	<i>-2.3830</i>	<i>117.2016</i>
AU049R	-42.4676	-32.0175	-9.4191	54.0124
	<i>-42.4674</i>	<i>-32.0160</i>	<i>-9.4162</i>	<i>54.0108</i>

Table 6. Topocentric plane East, North and Up coordinates for the Calibration pillars with the IVP as origin (0,0,0). These values are calculated from the Earth centred Cartesian coordinate results listed in Table 4. The Red (Italics) values are for the 1999 AUSLIG survey.

From	To	Diff X (m)	Diff Y (m)	Diff Z (m)	Diff X STD (m)	Diff Y STD (m)	Diff Z STD (m)
<i>IVP</i>	<i>AU017</i>	<i>6067.5192</i>	<i>-477.4043</i>	<i>-7436.3228</i>	<i>0.0017</i>	<i>0.0013</i>	<i>0.0014</i>
IVP	AU017	6067.5148	-477.4023	-7436.3253	0.0018	0.0011	0.0014
<i>IVP</i>	<i>AU045</i>	<i>-10.7687</i>	<i>-22.6353</i>	<i>-0.7403</i>	<i>0.0005</i>	<i>0.0008</i>	<i>0.0005</i>
IVP	AU045	-10.7679	-22.6353	-0.7397	0.0001	0.0001	0.0001
<i>IVP</i>	<i>AU046</i>	<i>-38.5865</i>	<i>4.9108</i>	<i>57.6658</i>	<i>0.0007</i>	<i>0.0009</i>	<i>0.0008</i>
IVP	AU046	-38.5867	4.9123	57.6668	0.0004	0.0005	0.0003
<i>IVP</i>	<i>AU047</i>	<i>-38.1109</i>	<i>-36.1832</i>	<i>14.3892</i>	<i>0.0006</i>	<i>0.0008</i>	<i>0.0006</i>
IVP	AU047	-38.1112	-36.1825	14.3883	0.0003	0.0003	0.0004
<i>IVP</i>	<i>AU048</i>	<i>8.4002</i>	<i>-91.7154</i>	<i>-72.5168</i>	<i>0.0007</i>	<i>0.0009</i>	<i>0.0007</i>
IVP	AU048	8.3972	-91.7167	-72.5164	0.0007	0.0005	0.0005
<i>IVP</i>	<i>AU049</i>	<i>44.4050</i>	<i>22.8847</i>	<i>-20.6290</i>	<i>0.0006</i>	<i>0.0009</i>	<i>0.0006</i>
IVP	AU049	44.4056	22.8845	-20.6303	0.0003	0.0004	0.0005
<i>IVP</i>	<i>AU050</i>	<i>-9.0864</i>	<i>-3.7892</i>	<i>10.4865</i>	<i>0.0006</i>	<i>0.0011</i>	<i>0.0007</i>
IVP	AU050	-9.0836	-3.7896	10.4890	0.0002	0.0004	0.0003
IVP	AU051	-4.0182	-4.6557	3.7374	0.0002	0.0004	0.0002
<i>IVP</i>	<i>AU052</i>	<i>-38.7148</i>	<i>4.9877</i>	<i>57.5612</i>	<i>0.0006</i>	<i>0.0008</i>	<i>0.0005</i>
IVP	AU052	-38.7142	4.9887	57.5617	0.0003	0.0003	0.0002
<i>IVP</i>	<i>AU054</i>	<i>9.9551</i>	<i>15.6292</i>	<i>8.5014</i>	<i>0.0006</i>	<i>0.0008</i>	<i>0.0005</i>
IVP	AU054	9.9598	15.6288	8.5010	0.0004	0.0003	0.0003
<i>IVP</i>	<i>AU055</i>	<i>-10.4791</i>	<i>0.1841</i>	<i>22.3317</i>	<i>0.0006</i>	<i>0.0008</i>	<i>0.0005</i>
IVP	AU056	3.2893	-1.9767	2.7170	0.0007	0.0008	0.0008
<i>IVP</i>	<i>DORIS</i>	<i>-4.4647</i>	<i>-4.3871</i>	<i>3.3729</i>	<i>0.0007</i>	<i>0.0012</i>	<i>0.0006</i>
IVP	DORIS	-4.4627	-4.3888	3.3726	0.0002	0.0004	0.0002

Table 7. Vectors from the IVP to the other network stations and the associated standard deviations. The Blue (Italics) results are from the 1999 AUSLIG survey.

7. Conclusion

This is the second survey of the SLR reference points at the Mt Stromlo Laser Ranging Observatory undertaken by NMD. The results shown in tables 1, 2, 3 and 4 are from a completely independent survey of the local network. No observations from the 1999 survey have been included in the GEOLAB adjustment.

Generally millimetre agreement with the 1999 survey has been obtained. A notable shift (in the order of 1.3mm) in the IVP position relative to AU052 has been detected, as was expected after the change to the vertical axis of the telescope. Interestingly the position of AU054 seems to be moving relative to the other network marks as well. The movement is in the order of 4mm horizontally with 1.8mm downward as well. This may well be caused by subsidence of the survey pillar and needs to be monitored in the future, but it has no effect on the survey results, as this mark was not constrained in any way in the adjustment.

A re-survey of the telescope is now required since additional telescope re-engineering has occurred since the date of this survey. This is not expected to have a significant effect but re-survey will ensure this. The update of the local tie information will be provided to the international community for subsequent inclusion in future reference frame refinements.

8. Acknowledgments

We would like to thank John Dawson from the SGAC for the determination of the telescope IVP. This process is a fundamental component of the reductions. Johns IVP determination report can be found at Appendix 2 of this report.

We would also like to thank Geoff Luton for his assistance with the GPS processing that provides the connection between AU017 (Tidbinbilla) and the two Mt Stromlo GPS points. Geoff's processing report can be found at Appendix 1 of this report.

9. References.

Johnston G. M., and W.E. Featherstone, *A New Gravimetric Geoid for Australia*, Proceedings, 24th National Surveying Conference of the Institute of Engineering and Mining Surveyors, Alice Springs, Australia, 1998.

Johnston. G. M., B. Twilley, S. Yates, *Total Station Levelling*, Proceedings, 26th National Surveying Conference, Darwin NT 8-12th July 2002

Appendix 1.

Gary

The latest (February 2002) STROMLO GPS local tie results files are attached below.

GPS data - days 035 to 040 inclusive of 2002.

Reference System - ITRF2000 (@ 2000.0 for fixed site STR1).

- STR1 to TIDB baseline (Bernese V4.2)

GPSEST.L27 and GPSEST27* are the appropriate files;
L3 observable using IGS final satellite ephemeris and pole products;
All except 7 L1 & L2 integer ambiguities resolved;
Tropo parameters at both sites at 2 hourly intervals;
10° elevation mask with elevation dependent weighting of observations;
IGS file PHAS_IGS.01 IGS antenna phase centre modelling applied;
TIDB 50103M108 rec.=ASHTECH Z-XII3 ant.=AOAD/M_T
ant.ht.=0.0614
STR1 50119M002 rec.=AOA SNR-12 ACT ant.=AOAD/M_T
ant.ht.=0.0000

- STR1 to STR2 baseline (Bernese V3.2)

GPSEST.L25 and GPSEST25* are the appropriate files;
L1&L2 single frequency observables using IGS final satellite ephemeris and pole products;
All except a total of 4 L1 & L2 integer ambiguities resolved;
No tropo parameters;
10° elevation mask with elevation dependent weighting of observations;
IGS file PHAS_IGS.01 IGS antenna phase centre modelling applied;
STR1 50119M002 rec.=AOA SNR-12 ACT ant.=AOAD/M_T
ant.ht.=0.0000
STR2 50119M001 rec.=JPS LEGACY ant.=JPSREGANT_DD_E
ant.ht.=0.0300

Geoff Luton
20th March 2002

Appendix 2.

Gary,

My overview is as follows...

IVP determination accuracy: < 1 mm
Hor. - Vert. Axis intersection: < 1.5 mm
Axis orthogonality: < 5' (300")

All quantities are ideal to within precision of the survey and analysis technique.

John

3DD						
DXYZ	AU045	IVP	10.7679	22.6353	0.7397	
COV	LG UPPR	0.0	1.0	0.0	1.0	0.0
ELEM	1.072306827995161e-08	3.793074826382594e-10	3.793074826382594e-10	3.793074826382594e-10		
ELEM	4.504252246651495e-09	-1.341909751836698e-10				
ELEM	4.468061806088612e-09					

axis: Axis Determination Software
Space Geodesy Analysis Centre - AUSLIG GEODESY
1999,2000 Version 0.01

Appendix 3 Prism designs used in Survey.

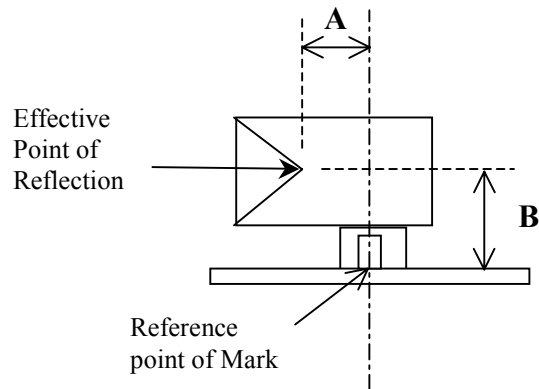

EOS Open Faced Retro-Reflectors. Value *A* is the horizontal offset between the effective point of reflection and the vertical axis of the survey point. Value *B* is the height offset between the effective point of reflection and the reference point of the survey point. The values are tabulated in Table 4 of the attached report.

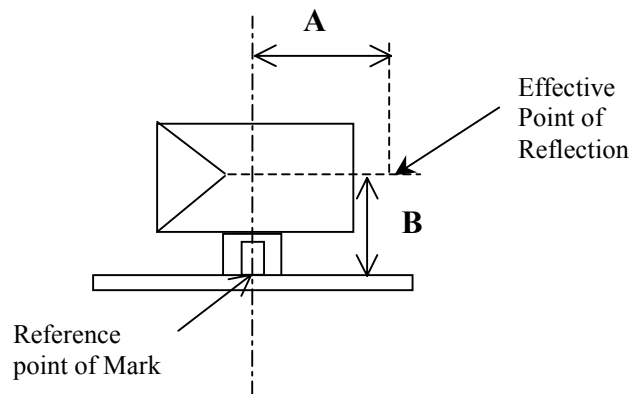

Leica Precision Solid Cube Retro-Reflectors. The effective point of reflection is 0.0344m behind the vertical axis of the survey point. The TC2003 applies this correction internally. A 0.0m offset needs to be applied in the reduction software external to the total station.

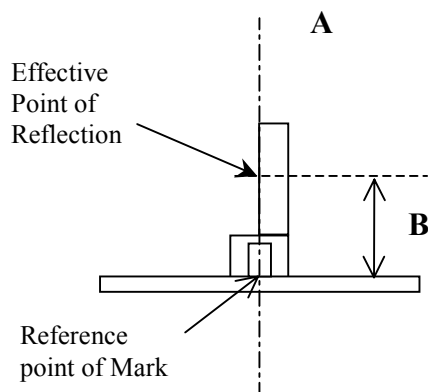

Leica Tape Retro-Reflector. The front face of the tape is coincident with the vertical axis of the survey point. No prism offset is required. However the TC2003 applies the -0.0344m offset used for the solid prisms. Therefore a +0.0344m offset needs to be applied in the reduction software external to the total station.