

AUSLIG GEODESY TECHNICAL REPORT 4

Yarragadee Satellite Laser Ranging Observatory Local Tie Survey May 2001

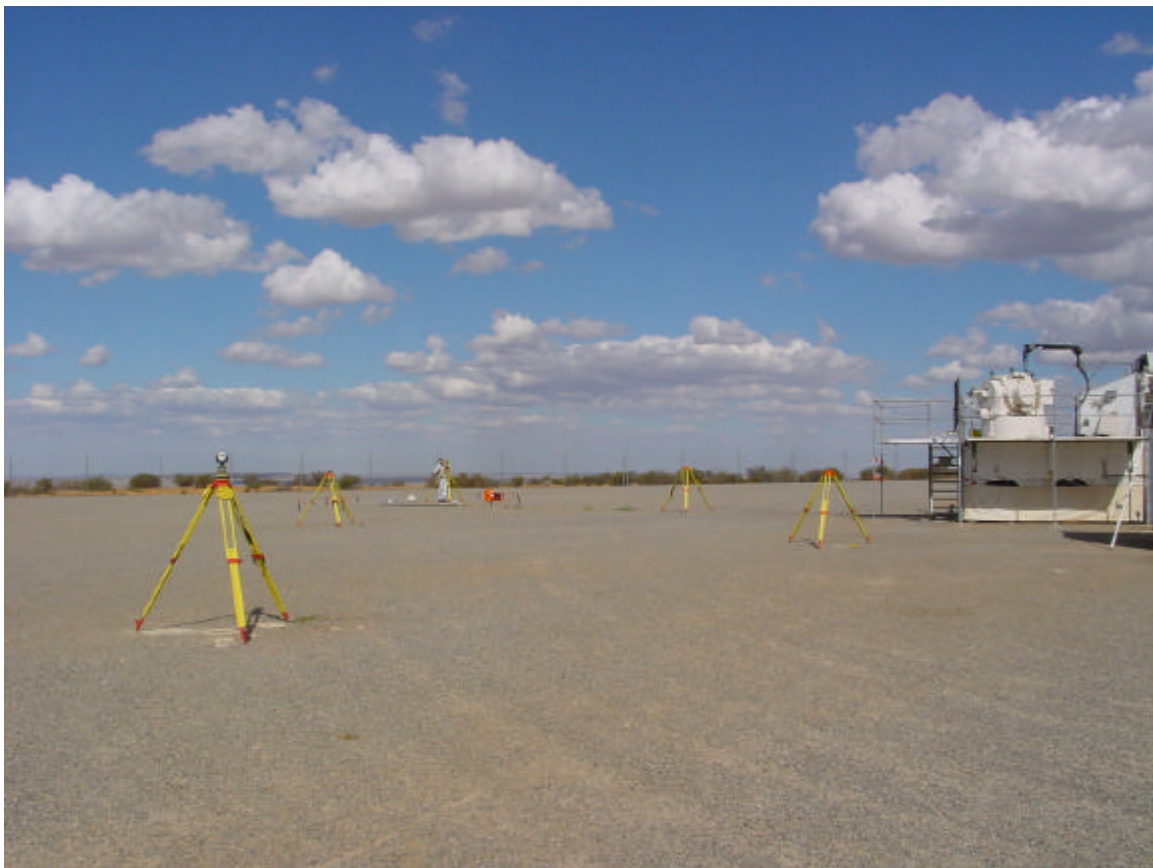

**Gary Johnston, John Dawson
and Steve Yates**

Australian Surveying and Land Information Group

Background

This local tie survey at Yaragadee was completed on the 1st to 3rd May 2001. The purpose of this survey was to repeat the determination of the invariant point of the Satellite Laser Ranging telescope (SLR IVP) and its relationship to the surrounding survey control, especially the SLR reference point DON95, the permanent GPS site YAR1 (DON95 RM4) and the permanent Glonass site YARR (AU053). The previous survey in August 1998 showed some differences from the original 1992 survey, especially in the area of DON95 RM4 (Johnston et al, 2000). This survey was intended to resolve the uncertainty created by those differences. The following report details the technique used in this survey and the results achieved. While internal consistency is of an extremely high standard some questions will be raised about the stability of the survey network in light of some of the differences encountered.

Observations

A Leica TC2003 Total Station was used for all horizontal angles, slope distances and Zenith angles. Where Zenith angles were to be used for vertical heighting, the Rueger method was used to determine the height of the trunion axis of the total station. Simplistically, the Rueger method consists of observing a levelling staff over a known point with the vertical circle of the total station set to 90 degrees (horizontal) and reading the height value. This value, along with the known relationship between the two ground marks can then be used to determine a height of instrument. Where observations to the telescope for IVP determination were carried out, both face left and face right heights were observed to eradicate collimation effects. This was repeated at two targets per setup for extra redundancy.

Observations were taken to the SLR telescope at a variety of horizontal and vertical settings in order to determine the location of the telescope invariant point (IVP). Three targets were placed on the telescope for the determination of the horizontal axis of rotation (see Figure 1). Two prisms were mounted on the top of the telescope stanchions. A third prism was mounted near the centre of rotation on top of the telescope, which was locked in a horizontal position. Observations were taken from AU053 (YARR) to all three targets with the telescope set at twenty-degree increments in azimuth (0, 20, 40,...,340) for a full 360 degrees. A second set of observations was taken to the same three targets from DON95 RM1 with the telescope again rotated through 360 degrees. These observations were again taken at twenty-degree increments (0,20, 40, 60,...,340).

For the vertical circle five Retro-reflector tape targets were positioned on the right hand face (looking down the bore sight) of the telescope itself. Observations were taken from AU053 (YARR) to each of these targets, at a ten-degree interval of vertical rotation of the telescope. The horizontal direction of the telescope was locked perpendicular to the line of sight. A second set of observations was taken from DON95 RM1 with the telescope now pointed perpendicular to that line. This perpendicular setting was based on the previous determination of the IVP. The perpendicular setting was only required approximately to allow maximum reflection from the tape retro reflectors used for this survey.

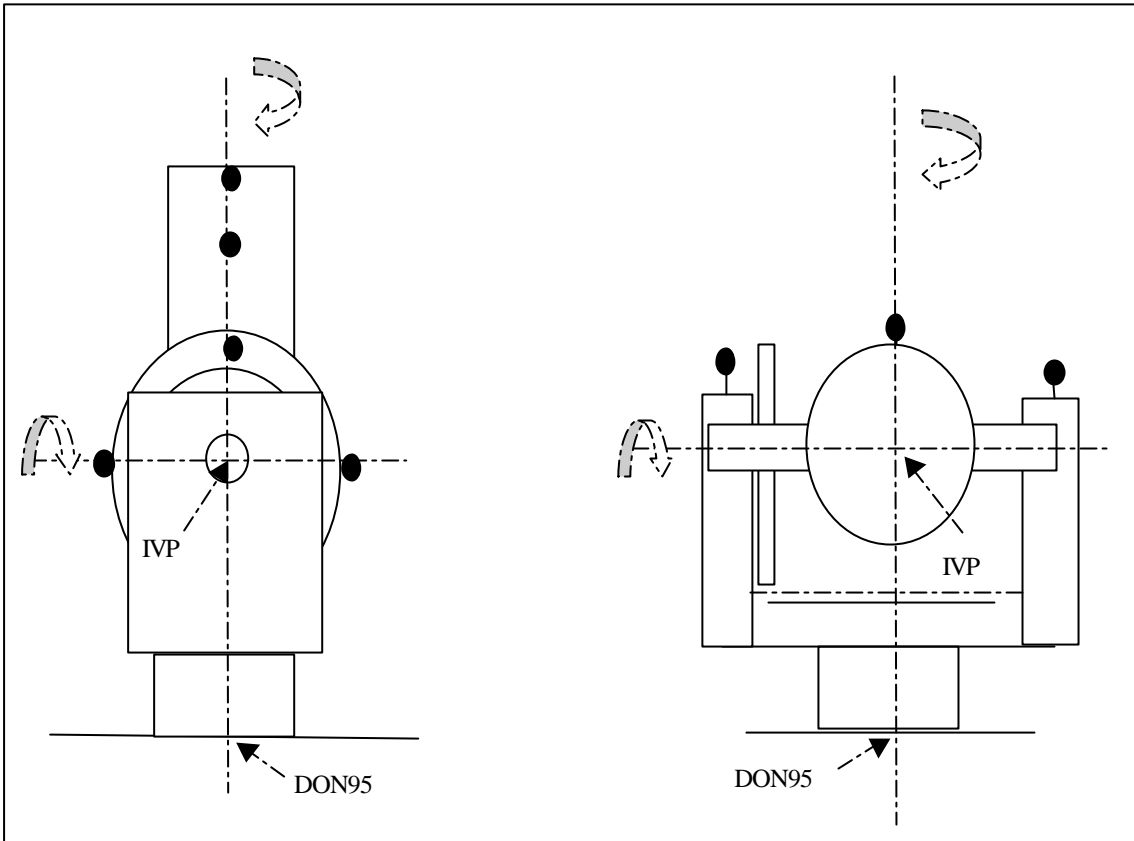

Figure 1a. Location of targets and points of interest on the Yaragadee SLR Telescope.



Figure 1b. Location of targets and points of interest on the Yaragadee SLR Telescope.

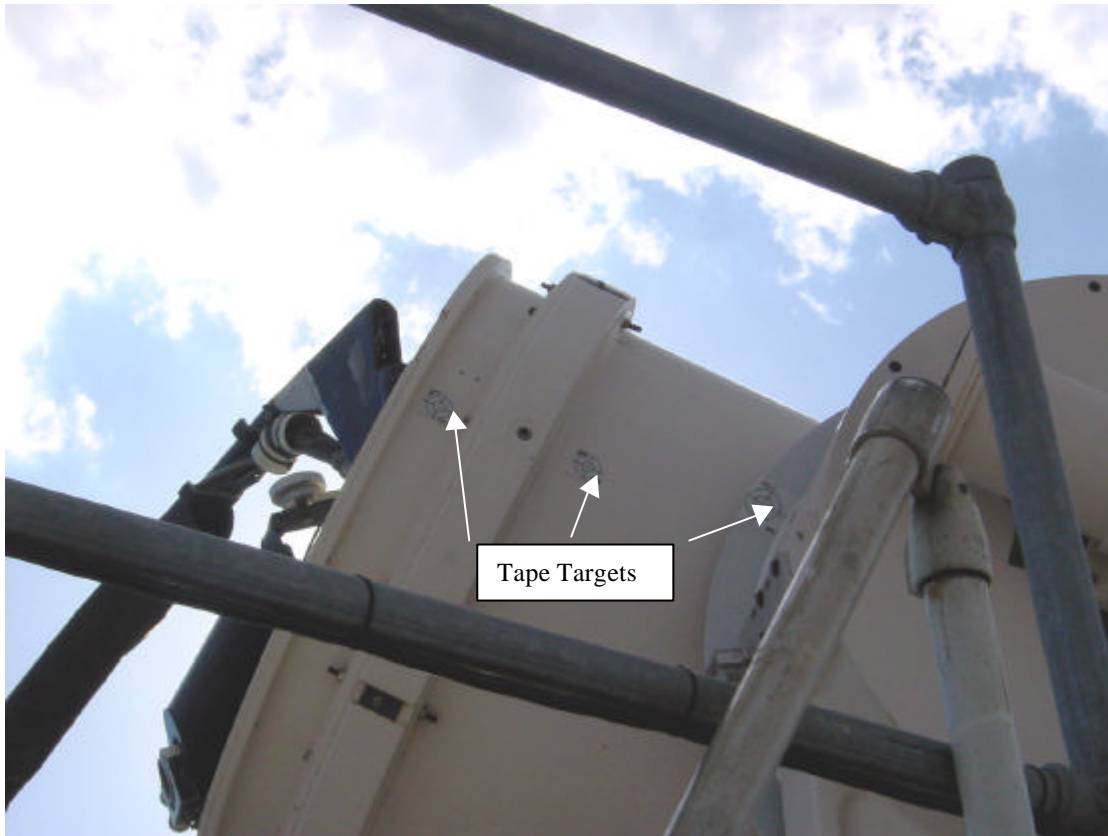

Figure 1c. Location of targets and points of interest on the Yaragadee SLR Telescope.

A Leica NA3003 bar-code level with an aluminium staff was used to carry orthometric height through the control network. With the exception of the calibration pillars all monuments were levelled. The levelling results in combination with AUSGeoid98 were used to transfer ellipsoidal height from DON95 RM4 (YAR1) through the network. The levelling results were checked using an independent technique described in ICSM Special Publication 1 section 2.4.2, which utilises the Leica TC2003 total station observing a fixed height target in a differential levelling mode where vertical angles and slope distances are used to determine height differences between change points. This technique is capable of achieving class 2a results and was found to give excellent agreement with the NA3003 results. A list of heights obtained from the check levelling are included in Table 8.

Orientation for the network was taken from the GPS baseline observed from DON95 RM4 to DON38 in the 1998 survey. No new GPS baselines were observed in this survey.

The co-ordinates for DON95 in terms of ITRF97 at 1997.0 have been adopted from the 1998 survey as datum for this survey. This site was chosen due to its apparent stability with respect to the remainder of the network.

Reductions

The observations were reduced in an identical manner to those in the 1998 survey. Appendix C Page 4 of the AUSLIG Geodesy Technical Report 3 which can be found at <http://www.auslig.gov.au/geodesy/techrpts/localsvy/localitiesv4.pdf> details the technique used for those reductions.

The determination of the Moblas 5 IVP is detailed in Appendix 1 to this report.

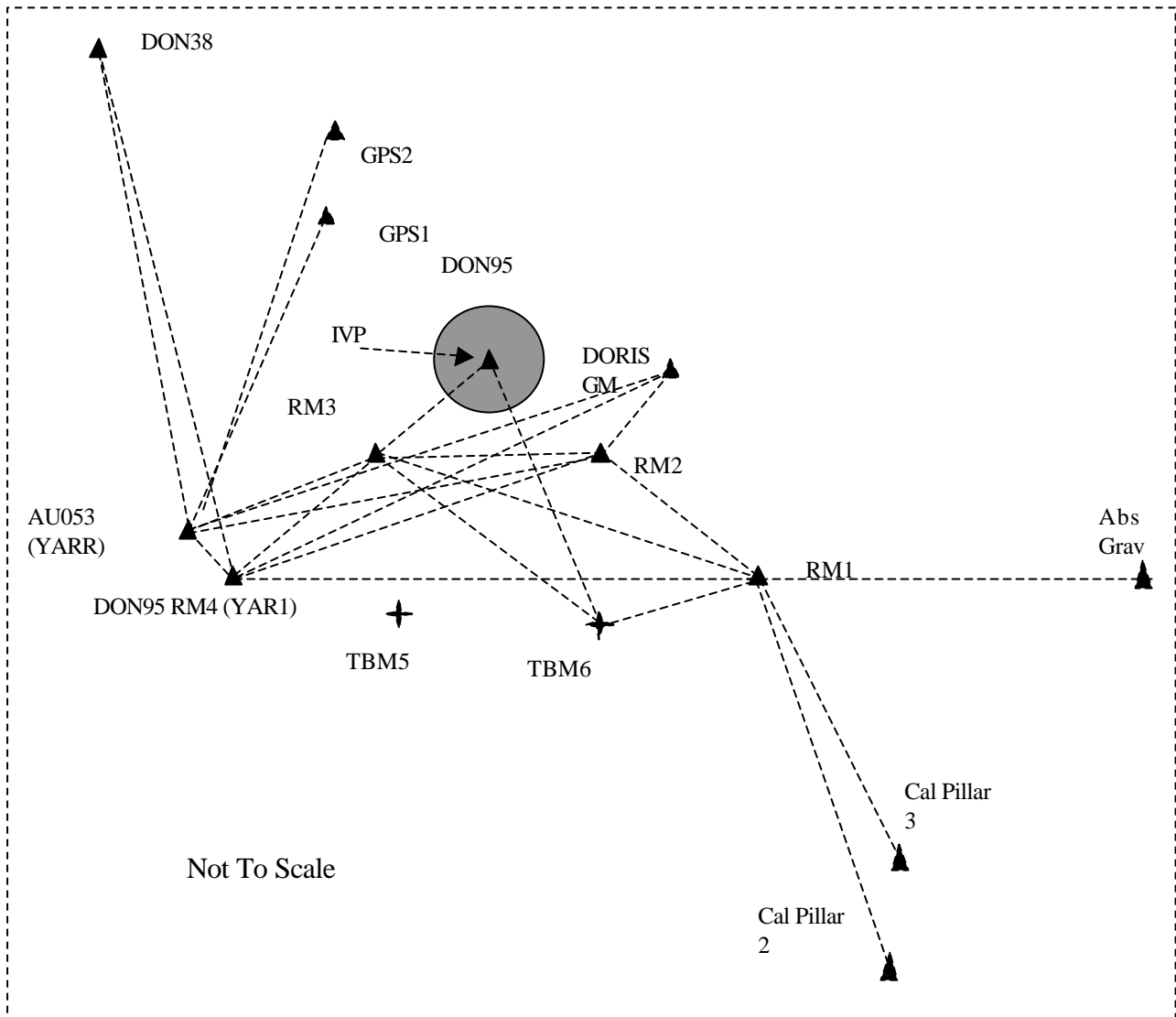

Figure 2. Network layout

The calibration pillars 2 and 3 were both observed in two separate ways. The first way was observations taken to the AUSLIG Leica prisms on a tribrach mount screwed directly onto the 5/8 spigot. The second way was observations taken directly to the SLR reflectors, which screw directly onto the 5/8 spigot. The results for the former are listed as Cal Pillar 2 and Cal Pillar 3 in the result tables. The latter are listed as Cal Target 2 and Cal Target 3 in the same tables. The coordinates listed for Cal Target 1 and Cal Target 2 refer to the effective measurement point of the reflectors, while Cal Pillar 2 and 3 refer to the intersection of the top of the stainless steel pillar plate with the vertical axis of a 5/8" f Whitworth threaded stainless steel spigot. No observations were taken to the Calibration pillar 1, which is over 3km from DON95.

Mark Descriptions

Moblas 5 IVP: Domes 50107S007. The intersection of the azimuth axis and elevation axis of rotation of the Yaragadee Moblas 5 Satellite Laser Ranging telescope.

AU053 (YARR): Domes 50107M006. The intersection of the top of the stainless steel plate with the vertical axis of a 5/8" *f* Whitworth threaded stainless steel spigot. This pillar plate is set at ground level and is embedded in concrete to a depth of 400mm. The GPS – Glonass antenna currently occupies this monument.

DON95: Domes 50107M001, CDP 7090. Punch mark in a circular brass plaque 0.080m in diameter set in concrete. The plaque is inscribed "Australian Survey Office Survey Mark" and is stamped DON 95. This is the primary reference point for the Moblas 5 SLR system.

DON95 RM1: Punch Mark in brass rod 0.010m diameter set in concrete. A brass plaque stamped "RM1" is set in concrete nearby. The Latvian PSLR system (CDP 7847, Domes 50107S009) was temporarily positioned over this mark. The eccentricities to the PSLR are not available as part of this survey.

DON95 RM2: Punch Mark in brass rod 0.010m diameter set in concrete. A brass plaque stamped "RM2" is set in concrete nearby.

DON95 RM3: Punch Mark in brass rod 0.010m diameter set in concrete. A brass plaque stamped "RM3" is set in concrete nearby.

DON95 RM4 (YARI): Domes 50107M004, AU029. Punch Mark in brass rod 0.010m diameter set in concrete. A brass plaque stamped "RM4" is set in concrete nearby. This mark constitutes the IGS GPS station.

DON38: Mark is a "Lands and Surveys" pre cast SSM stamped DON38. RM's 1,2 and 3 are brass rods set in concrete. RM4 is a steel rod set in concrete.

DORIS GM: Domes 50107M005. Ground mark under the DORIS antenna. Mark consists of a punch mark in a brass pin set in concrete.

GPS Timing 1: The intersection of the vertical axis of the support pole for the GPS timing antenna with the base of the antenna itself. GPS1 is the more eastern of the two GPS timing antennae.

GPS Timing 2: The intersection of the vertical axis of the support pole for the GPS timing antenna with the base of the antenna itself. GPS2 is the more western of the two timing antennae.

TBM5, TBM6. Screws driven into bitumen for temporary observation standpoints.

Calibration Pillars 2 and 3: Concrete pillars approximately 0.3m diameter. The mark refers to the intersection of the top of the stainless steel plate with the vertical axis of a 5/8" *f* Whitworth threaded stainless steel spigot. The pillars are used to mount calibration reflectors for the SLR system and are also referred to as Moblas 5 pillar2, and 3.

Calibration Targets 2 and 3. The reflective point of the SLR reflectors mounted on calibration pillars 2 and 3 respectively.

Results

| STATION | LATITUDE (DMS) | | | LONGITUDE (DMS) | | | ELIP HEIGHT (m) | STD DEV (m) | STD DEV (m) | STD DEV (m) | |
|--------------|----------------|----|---|-----------------|-----|----|-----------------|-------------|-------------|-------------|--------|
| | S | 29 | 2 | | | | | | | | |
| CAL PILLAR 2 | S | 29 | 2 | 42.66822 | 115 | 20 | 49.68279 | 241.2147 | 0.0066 | 0.0026 | 0.0009 |
| CAL PILLAR 3 | S | 29 | 2 | 44.21057 | 115 | 20 | 49.07816 | 242.0639 | 0.0067 | 0.0018 | 0.0006 |
| CAL TARGET 2 | S | 29 | 2 | 42.66712 | 115 | 20 | 49.68301 | 241.2791 | 0.0066 | 0.0026 | 0.0009 |
| CAL TARGET 3 | S | 29 | 2 | 44.20963 | 115 | 20 | 49.07838 | 242.1284 | 0.0067 | 0.0018 | 0.0006 |
| MOBLAS 5 IVP | S | 29 | 2 | 47.39483 | 115 | 20 | 48.28626 | 244.5450 | 0.0011 | 0.0012 | 0.0020 |
| DON95 RM1 | S | 29 | 2 | 46.67510 | 115 | 20 | 48.53347 | 241.0612 | 0.0006 | 0.0004 | 0.0002 |
| DON95 RM2 | S | 29 | 2 | 47.08347 | 115 | 20 | 48.39280 | 241.2291 | 0.0004 | 0.0004 | 0.0005 |
| DON95 RM3 | S | 29 | 2 | 47.48858 | 115 | 20 | 48.63932 | 241.3691 | 0.0002 | 0.0003 | 0.0003 |
| DON95 RM4 | S | 29 | 2 | 47.61247 | 115 | 20 | 49.10464 | 241.3180 | 0.0001 | 0.0001 | 0.0001 |
| GPS TIMING 1 | S | 29 | 2 | 47.60072 | 115 | 20 | 47.69235 | 245.5454 | 0.0009 | 0.0068 | 0.0004 |
| GPS TIMING 2 | S | 29 | 2 | 47.59423 | 115 | 20 | 47.77890 | 245.6982 | 0.0010 | 0.0068 | 0.0004 |
| ABS GRAV | S | 29 | 2 | 45.84349 | 115 | 20 | 47.93529 | 240.7876 | 0.0058 | 0.0037 | 0.0003 |
| TBM6 | S | 29 | 2 | 47.21778 | 115 | 20 | 48.85872 | 241.2016 | 0.0003 | 0.0003 | 0.0005 |
| YARR (AU053) | S | 29 | 2 | 47.73826 | 115 | 20 | 49.09403 | 241.3952 | 0.0002 | 0.0001 | 0.0002 |
| DON38 | S | 29 | 2 | 50.19616 | 115 | 20 | 47.09087 | 242.8251 | 0.0032 | 0.0022 | 0.0005 |
| DON95 | S | 29 | 2 | 47.39450 | 115 | 20 | 48.28560 | 241.3629 | 0.0002 | 0.0005 | 0.0003 |
| DORIS | S | 29 | 2 | 46.91853 | 115 | 20 | 48.00738 | 241.1996 | 0.0005 | 0.0007 | 0.0003 |
| DON38 RM1 | S | 29 | 2 | 50.40284 | 115 | 20 | 46.87201 | 242.5670 | 0.0059 | 0.0051 | 0.0005 |
| DON38 RM2 | S | 29 | 2 | 49.90206 | 115 | 20 | 46.98819 | 242.5382 | 0.0073 | 0.0030 | 0.0005 |
| DON38 RM3 | S | 29 | 2 | 50.26121 | 115 | 20 | 47.43910 | 242.7109 | 0.0035 | 0.0070 | 0.0005 |
| DON38 RM4 | S | 29 | 2 | 50.34926 | 115 | 20 | 47.13083 | 242.5937 | 0.0074 | 0.0027 | 0.0005 |

Table 1. Latitude, Longitude and Ellipsoidal height and the associated standard deviation for the network stations as determined in the May 2001 survey. ITRF97 @1997.00 co-ordinates and GRS80 ellipsoid adopted at DON95 RM4 (YARI).

| STATION | X (m) | Y (m) | Z (m) | STD DEV (m) | STD DEV (m) | STD DEV (m) |
|--------------|---------------|--------------|---------------|-------------|-------------|-------------|
| CAL PILLAR 2 | -2389071.2719 | 5043376.9008 | -3078397.6219 | 0.0033 | 0.0025 | 0.0058 |
| CAL PILLAR 3 | -2389046.9358 | 5043363.7390 | -3078439.5496 | 0.0028 | 0.0025 | 0.0059 |
| CAL TARGET 2 | -2389071.3085 | 5043376.9639 | -3078397.6236 | 0.0033 | 0.0025 | 0.0058 |
| CAL TARGET 3 | -2389046.9715 | 5043363.8001 | -3078439.5556 | 0.0028 | 0.0025 | 0.0059 |
| MOBLAS 5 IVP | -2389008.1245 | 5043331.8537 | -3078526.4641 | 0.0013 | 0.0017 | 0.0014 |
| DON95 RM1 | -2389017.4709 | 5043335.9613 | -3078505.4000 | 0.0004 | 0.0004 | 0.0005 |
| DON95 RM2 | -2389011.4809 | 5043332.2064 | -3078516.4733 | 0.0004 | 0.0005 | 0.0004 |
| DON95 RM3 | -2389014.9685 | 5043323.9889 | -3078527.4454 | 0.0003 | 0.0003 | 0.0002 |
| DON95 RM4 | -2389025.5339 | 5043316.8853 | -3078530.7553 | 0.0001 | 0.0001 | 0.0001 |
| GPS TIMING 1 | -2388992.6596 | 5043336.7414 | -3078532.4916 | 0.0060 | 0.0033 | 0.0008 |
| GPS TIMING 2 | -2388994.8747 | 5043335.9474 | -3078532.3910 | 0.0060 | 0.0033 | 0.0009 |
| ABS GRAV | -2389008.0644 | 5043353.9081 | -3078482.8829 | 0.0022 | 0.0041 | 0.0051 |
| TBM6 | -2389022.0034 | 5043324.9737 | -3078520.0751 | 0.0003 | 0.0005 | 0.0004 |
| YARR (AU053) | -2389024.4984 | 5043315.3698 | -3078534.1788 | 0.0001 | 0.0002 | 0.0002 |
| DON38 | -2388960.3255 | 5043306.4945 | -3078601.0311 | 0.0027 | 0.0006 | 0.0028 |
| DON95 | -2389006.9196 | 5043329.3517 | -3078524.9102 | 0.0004 | 0.0003 | 0.0002 |
| DORIS GM | -2389003.1016 | 5043338.8754 | -3078512.0193 | 0.0005 | 0.0005 | 0.0005 |
| DON38 RM1 | -2388953.5549 | 5043306.0333 | -3078606.4688 | 0.0059 | 0.0007 | 0.0052 |
| DON38 RM2 | -2388959.5897 | 5043311.4304 | -3078592.9756 | 0.0027 | 0.0038 | 0.0064 |
| DON38 RM3 | -2388968.3810 | 5043301.4923 | -3078602.7264 | 0.0063 | 0.0035 | 0.0031 |
| DON38 RM4 | -2388960.2362 | 5043303.7806 | -3078605.0395 | 0.0027 | 0.0036 | 0.0065 |

Table 2. Earth Centred Cartesian co-ordinates and the associated standard deviation for the network stations as determined in the May 2001 survey. ITRF97 @1997.00 co-ordinates adopted at DON95 RM4 (YARI).

| STATION | AHD HEIGHT (M) |
|---------------|----------------|
| DON95 | 266.5850 |
| DON95 RM1 | 266.2814 |
| DON95 RM2 | 266.4503 |
| DON95 RM3 | 266.5909 |
| DON95 RM4 | 266.5392 |
| YARR (AU053) | 266.6165 |
| ABS GRAV | 266.0070 |
| GRAV 80900320 | 266.6043 |
| TBM5 | 266.5271 |
| TBM6 | 266.4228 |
| DON38 | 268.0544 |
| DON38 RM1 | 267.7962 |
| DON38 RM2 | 267.7675 |
| DON38 RM3 | 267.9402 |
| DON38 RM4 | 267.8229 |

Table 3. AHD heights of network stations where Orthometric levelling was possible in the May 2001 survey. The height of DON95 has been adopted from value derived by J skates, DOLA WA as listed on folio 24 of AUSLIG File 98/406. It should be noted that this value is 0.0069m lower than the value derived by subtracting AUSGeoid98 N values from the ellipsoidal heights tabulated in Table 1 above.

| FROM | TO | MAJ SEMI (m) | MED SEMI (m) | MIN SEMI (m) | DIST (m) | AZ,VANG | AZ,VANG | AZ,VANG |
|--------------|--------------|--------------|--------------|--------------|----------|----------|----------|----------|
| MOBLAS 5 IVP | DON95 | 0.0057 | 0.0037 | 0.0031 | 3.1822 | (0, 90) | (90, 0) | (0, 0) |
| MOBLAS 5 IVP | DON95 RM1 | 0.0057 | 0.0036 | 0.0034 | 23.4078 | (0, 90) | (90, 0) | (0, 0) |
| MOBLAS 5 IVP | DON95 RM2 | 0.0058 | 0.0036 | 0.0032 | 10.5455 | (0, 90) | (90, 0) | (0, 0) |
| MOBLAS 5 IVP | DON95 RM3 | 0.0057 | 0.0035 | 0.0030 | 10.4718 | (0, 90) | (90, 0) | (0, 0) |
| MOBLAS 5 IVP | DON95 RM4 | 0.0057 | 0.0034 | 0.0030 | 23.3571 | (0, 90) | (90, 0) | (0, 0) |
| MOBLAS 5 IVP | YARR (AU053) | 0.0057 | 0.0034 | 0.0030 | 24.4814 | (0, 90) | (90, 0) | (0, 0) |
| MOBLAS 5 IVP | DON38 | 0.0113 | 0.0058 | 0.0036 | 92.1308 | (35, 0) | (0, 90) | (125, 0) |
| MOBLAS 5 IVP | DORIS GM | 0.0057 | 0.0039 | 0.0033 | 16.8281 | (0, 90) | (90, 0) | (0, 0) |
| MOBLAS 5 IVP | GPS1 | 0.0194 | 0.0057 | 0.0033 | 17.3027 | (97, 0) | (0, 90) | (187, 0) |
| MOBLAS 5 IVP | GPS2 | 0.0194 | 0.0057 | 0.0032 | 15.0813 | (97, 0) | (0, 90) | (187, 0) |
| MOBLAS 5 IVP | ABS GRAV | 0.0194 | 0.0057 | 0.0036 | 48.8439 | (147, 0) | (0, 90) | (237, 0) |
| MOBLAS 5 IVP | TBM6 | 0.0058 | 0.0035 | 0.0031 | 16.7564 | (0, 90) | (90, 0) | (0, 0) |
| MOBLAS 5 IVP | DON38 RM1 | 0.0221 | 0.0058 | 0.0039 | 100.2261 | (41, 0) | (0, 90) | (131, 0) |
| MOBLAS 5 IVP | DON38 RM2 | 0.0207 | 0.0087 | 0.0058 | 84.8323 | (172, 0) | (262, 0) | (0, 90) |
| MOBLAS 5 IVP | DON38 RM3 | 0.0199 | 0.0102 | 0.0058 | 91.1992 | (94, 0) | (184, 0) | (0, 90) |
| MOBLAS 5 IVP | DON38 RM4 | 0.0209 | 0.0082 | 0.0058 | 96.2054 | (176, 0) | (266, 0) | (0, 90) |
| CP2 | MOBLAS 5 IVP | 0.0193 | 0.0066 | 0.0062 | 150.3900 | (14, 0) | (104, 0) | (0, 90) |
| CP3 | MOBLAS 5 IVP | 0.0193 | 0.0059 | 0.0051 | 100.3849 | (11, 0) | (0, 90) | (101, 0) |
| CT2 | MOBLAS 5 IVP | 0.0193 | 0.0066 | 0.0062 | 150.4228 | (14, 0) | (104, 0) | (0, 90) |
| CT3 | MOBLAS 5 IVP | 0.0193 | 0.0059 | 0.0051 | 100.4129 | (11, 0) | (0, 90) | (101, 0) |

Table 4. Three-dimensional line error ellipses from MOBLAS 5 IVP to all other network stations as computed from the May 2001 survey data. ITRF97 @1997.00 co-ordinates adopted at DON95 RM4 (YARI). The three axes are Semi-Major, Semi-medium and Semi-Minor. The associated azimuth and zenith angles of these axes are also listed. A 95% confidence level has been adopted.

| STATION | Diff X (m) | Diff Y (m) | Diff Z (m) | Range (m) |
|--------------|------------|------------|------------|-----------|
| MOBLAS 5 IVP | 0.0000 | 0.0000 | 0.0000 | 0.0000 |
| | | | | |
| DON95 | 1.2049 | -2.5020 | 1.5539 | 3.1822 |
| DON95 | 1.2048 | -2.5019 | 1.5517 | 3.1810 |
| DON95 | 1.2060 | -2.5010 | 1.5530 | 3.1814 |
| | | | | |
| DON95 RM1 | -9.3464 | 4.1076 | 21.0641 | 23.4078 |
| DON95 RM1 | -9.3469 | 4.1079 | 21.0636 | 23.4076 |
| DON95 RM1 | -9.3460 | 4.1070 | 21.0670 | 23.4101 |
| | | | | |
| DON95 RM2 | -3.3564 | 0.3527 | 9.9908 | 10.5455 |
| DON95 RM2 | -3.3573 | 0.3529 | 9.9901 | 10.5451 |
| DON95 RM2 | -3.3560 | 0.3550 | 9.9950 | 10.5494 |
| | | | | |
| DON95 RM3 | -6.8440 | -7.8648 | -0.9813 | 10.4718 |
| DON95 RM3 | -6.8450 | -7.8711 | -0.9817 | 10.4772 |
| DON95 RM3 | -6.8400 | -7.8700 | -0.9760 | 10.4726 |
| | | | | |
| DON95 RM4 | -17.4094 | -14.9684 | -4.2912 | 23.3571 |
| DON95 RM4 | -17.4072 | -14.9695 | -4.2896 | 23.3559 |
| DON95 RM4 | -17.3990 | -14.9720 | -4.2820 | 23.3500 |
| | | | | |
| DON38 | 47.7990 | -25.3592 | -74.5670 | 92.1308 |
| DON38 | 47.8004 | -25.3523 | -74.5692 | 92.1313 |
| DON38 | 47.8030 | -25.3420 | -74.5590 | 92.1216 |
| | | | | |
| DORIS GM | 5.0229 | 7.0217 | 14.4448 | 16.8281 |
| DORIS GM | 5.0246 | 7.0188 | 14.4448 | 16.8274 |
| DORIS GM | 5.0240 | 7.0200 | 14.4500 | 16.8322 |

Table 5. Vectors from MOBLAS 5 IVP to the other network stations listed in the 1992 report. 1992 results (shown in RED) are in terms of WGS84, the 1998 results (shown in black) are in ITRF97 @ 1997.00 and the May 2001 results (shown in purple) are also in terms of ITRF97 @ 1997.0.

| STATION | Diff EAST(m) | Diff NORTH (m) | Diff HEIGHT (m) |
|--------------|--------------|----------------|-----------------|
| MOBLAS 5 IVP | 0.0000 | 0.0000 | 0.0000 |
| | | | |
| DON95 | -0.0178 | 0.0102 | -3.1822 |
| DON95 | -0.0178 | 0.0083 | -3.1809 |
| | 0.0000 | 0.0019 | -0.0013 |
| DON95 RM1 | 6.6882 | 22.1598 | -3.4838 |
| DON95 RM1 | 6.6886 | 22.1595 | -3.4832 |
| | -0.0004 | 0.0003 | -0.0006 |
| DON95 RM2 | 2.8823 | 9.5866 | -3.3159 |
| DON95 RM2 | 2.8830 | 9.5862 | -3.3150 |
| | -0.0007 | 0.0004 | -0.0009 |
| DON95 RM3 | 9.5520 | -2.8863 | -3.1760 |
| DON95 RM3 | 9.5556 | -2.8892 | -3.1803 |
| | -0.0036 | 0.0029 | 0.0043 |
| DON95 RM4 | 22.1414 | -6.7008 | -3.2271 |
| DON95 RM4 | 22.1398 | -6.7003 | -3.2295 |
| | 0.0016 | -0.0008 | 0.0024 |
| DON38 | -32.3414 | -86.2505 | -1.7206 |
| DON38 | -32.3457 | -86.2497 | -1.7146 |
| | 0.0043 | -0.0008 | -0.0060 |
| DORIS GM | -7.5453 | 14.6650 | -3.3454 |
| DORIS GM | -7.5456 | 14.6634 | -3.3484 |
| | 0.0003 | 0.0016 | 0.0030 |
| YARR (AU053) | 21.8543 | -10.5738 | -3.1498 |
| YARR (AU053) | 21.8533 | -10.5736 | -3.1507 |
| | 0.0010 | -0.0002 | 0.0009 |

Table 6. Differences between the May 2001 survey (shown in purple) and the August 1998 survey (shown in black) in terms of East, North and Up.

| STATION | Range from IVP (m) | Diff Distance (m) |
|--------------|--------------------|-------------------|
| MOBLAS 5 IVP | 0.0 | |
| | | |
| Cal Target 2 | 150.4228 | |
| Cal Target 2 | 150.4229 | -0.0001 |
| Cal Target 2 | 150.4245 | -0.0017 |
| Cal Target 3 | 100.4129 | |
| Cal Target 3 | 100.4137 | -0.0008 |
| Cal Target 3 | 100.4185 | -0.0056 |

Table 7. Range from the MOBLAS 5 IVP to the effective measurement point of the calibration reflectors. Results shown in RED are from the 1992 survey. Results shown in purple are from the May 2001 survey. Results shown in black are from the 1998 survey.

| STATION | AHD HEIGHT (M) |
|-----------------|----------------|
| DON95 RM1 | 266.2814 |
| DON95 RM2 | 266.4502 |
| DON95 RM3 | 266.5910 |
| DON95 RM4 | 266.5394 |
| YARR TOP SPIGOT | 266.6268 |
| ABS GRAV | 266.0067 |

Table 8. Results EDM height traversing. DON95 RM1 has been adopted as datum.

Conclusion

This is the second survey of the SLR reference points at the Yarragadee Laser Ranging Observatory using the technique outlined earlier in this report. The results shown in tables 1, 2, 3 and 4 are from a completely independent survey of the local network at Yarragadee. No observations from previous surveys have been included in the Geolab adjustment.

Two to three millimetre agreements have been obtained between the currently adopted results (1998 survey) and the new survey results, as is demonstrated in the tables 5, 6 and 7, for the primary sites in the network including the eccentricity from DON95 to MOBLAS 5 IVP. The agreement between DON95 and DON95 RM4 (YAR1) is not as encouraging showing a misclose of 3.7mm in height. The difference is even more obvious at DON95 RM3 where a misclose in height of 5.6mm from DON95 is evident.

Local movement between the monuments at this site is apparent and explains the difference between the 1992 survey and the 1998 as documented in the 2000 report (Johnston et al, 2000). In particular DON95 RM3 and to a lesser extent DON95 RM4 appear to be moving, particularly in height. The placement of deep driven benchmarks near the perimeter of the bitumen compound will allow a full assessment of this motion. The study of water table effects and subsoil composition may also enhance the understanding of site motions.

The differences encountered between DON95 and DON95 RM4 are not large enough to warrant to resubmission of the local tie Sinex file to IERS for this site.

References

Johnston, G., J. Dawson, B. Twilley, P. Digney, *Accurate Survey Connections Between Co-located Space Geodesy Techniques at Australian Fundamental Geodetic Observatories*. AUSLIG Geodesy Technical Report 3, November 2000.