

**NORTH BROKEN HILL, NSW  
(CORONA AND FOWLERS GAP 1:100 000 SHEET AREAS),  
AIRBORNE GEOPHYSICAL SURVEY, 1995/1996,  
OPERATIONS REPORT**

by

**R. C. Brodie**

**Australian Geological Survey Organisation  
Record 1999/23**

## **DEPARTMENT OF INDUSTRY, SCIENCE & RESOURCES**

Minister for Industry, Science and Resources: Senator the Hon. Nick Minchin  
Parliamentary Secretary: The Hon. Warren Entsch, MP  
Secretary: Russell Higgins

## **AUSTRALIAN GEOLOGICAL SURVEY ORGANISATION**

Executive Director: Dr Neil Williams

© Commonwealth of Australia 1999

**ISSN: 1039 – 0073**

**ISBN: 0 642 39782 1**

Bibliographic reference: Brodie, R.C., 1999. Title - North Broken Hill, NSW, (Corona and Fowlers Gap 1:100 000 Sheet areas), Airborne Geophysical Survey, 1995/1996, Operations Report. Australian Geological Survey Organisation, Record 1999/23.

This work is copyright. Apart from any fair dealings for the purposes of study, research, criticism or review, as permitted under the *Copyright Act 1968*, no part may be reproduced by any process without written permission. Copyright is the responsibility of the Executive Director, Australian Geological Survey Organisation. Inquiries should be directed to the **Information Officer, Australian Geological Survey Organisation, GPO Box 378, Canberra City, ACT, 2601.**

AGSO has tried to make the information in this product as accurate as possible. However, AGSO does not guarantee that the information is totally accurate or complete. Therefore, you should not rely solely on this information when making a commercial decision.

# CONTENTS

## SUMMARY

<b>1. SURVEY AREA AND PARAMETERS.....</b>	<b>1</b>
(i) Area Description .....	1
(ii) Survey Parameters .....	1
<b>2. LOGISTICS.....</b>	<b>1</b>
(i) Operating Base and Dates of Flying .....	1
(ii) Survey Aircraft and Field Crew .....	2
<b>3. SURVEY EQUIPMENT .....</b>	<b>2</b>
(i) Major Equipment .....	2
(ii) Navigation.....	3
(iii) Magnetometer .....	4
(iv) Gamma-ray Spectrometer .....	4
(v) Altimeter .....	5
(vi) Barometer and Thermometer .....	5
(vii) Base Station Magnetometer .....	5
(viii) Aircraft Data Acquisition .....	5
<b>4. CALIBRATION .....</b>	<b>6</b>
(i) Compensation for the Magnetic Field of the Aircraft.....	6
(ii) Gamma-ray Spectrometer Calibration .....	6
<b>5. DATA PROCESSING.....</b>	<b>7</b>
(i) Data Checking and Editing .....	7
(ii) Flight Path Recovery .....	7
(iii) Magnetic Data Processing .....	8
(iv) Gamma-ray Spectrometer Data Processing .....	9
(v) Digital Elevation Model Data Processing.....	11
(vi) Final Products .....	13
<b>6. REFERENCES .....</b>	<b>14</b>

## APPENDICES

## APPENDICES

- A. Survey Area
- B. Flying Dates and Production Kilometres Flown
- C. Real Time Differential GPS
- D. Specifications of G833 Helium Magnetometer
- E. Specifications of RMS Instruments Automatic Aeromagnetic Digital Compensator
- F. Specifications of Gamma-ray Spectrometer Components
- G. Specifications of G833 Base Station Magnetometers
- H. Aircraft Data Acquisition System
- I. Compensation Results
- J. Gamma-ray Spectrometer Test Line Location
- K. The World Geodetic System 1984 Datum
- L. Corrections to Differential GPS Navigation Data
- M. Geophysical Maps
- N. AGSO Archive Data, Grid and Magnetic Tape Format for Airborne Geophysical Data

## **SUMMARY**

The Australian Geological Survey Organisation (AGSO) flew an airborne geophysical survey of 47,920 line kilometres over the Corona and Fowlers Gap 1:100 000 map Sheet areas on the Broken Hill 1:250 000 map Sheet area.

The survey was flown as part of the Broken Hill Exploration Initiative, a National Geoscience Mapping Accord project implemented by AGSO, the New South Wales Department of Mineral Resources and the Department of Minerals and Energy South Australia.

The survey was flown along east-west flight lines spaced mainly 100 m apart (200 m in some areas) at a nominal altitude of 60 m above ground level. AGSO flew the survey over two periods; from September to December 1995 and from March to April 1996.

The total magnetic intensity, gamma-ray spectrometric and digital elevation model data which were collected during the survey, have been processed and are available for purchase, in both digital (point located data and gridded) and map form, from the Australian Geological Survey Organisation.

## 1. SURVEY AREA AND PARAMETERS

### (i) Area Description

The airborne geophysical survey covers the entire Corona and western three quarters of the Fowlers Gap 1:100 000 map Sheet areas, which lie on the Broken Hill 1:250 000 map Sheet area of far western New South Wales. The exact survey area is shown in Appendix A.

### (ii) Survey Parameters

Altitude:	60 m above ground level
Flight line direction:	East – West
Tie line direction:	North – South
Survey line spacing	
Flight line spacing:	100 and 200 m
Tie line spacing:	1000 and 2000 m
Survey distance flown	
Lines:	43,476 km
Ties:	4,444 km
Total distance:	47,920 km
Sampling interval	
Magnetics:	0.1 s (approx 7 m)
Gamma-ray spectrometrics:	1.0 s (approx 70 m)
GPS:	1.0 s (approx 70 m)
Doppler:	1.0 s (approx 70 m)
Altimeter:	1.0 s (approx 70 m)
Barometric pressure:	10.0 s (approx 700 m)
Temperature:	10.0 s (approx 700 m)

Eighty five percent of the survey area was covered at 100 m line spacing. The remaining fifteen percent, on the western margin of the area where cover over magnetic rocks is thicker, was covered at 200 m line spacing.

## 2. LOGISTICS

### (i) Operating Base and Dates of Flying

#### (a) Operating Base

The survey continued on from the Frome airborne geophysical survey (Richardson, 1996), with the same crew and equipment. Aircraft and crew were based at Broken Hill in New South Wales for the duration of the survey.

#### (b) Flying Dates

In total the survey was undertaken over a period of seven months. Three other surveys were undertaken by the AGSO aircraft during this period. Production flying commenced on 16 September and continued through until 28 September 1995 during a delay in operations on the Frome survey while landholders in the area were mustering stock. Other production flights during the Frome survey were undertaken on 11, 12 and 20 October. After completion of the Frome survey on 25 November production flying

continued through until 6 December 1995, after which a survey of the Jemalong Plains was flown and operations ceased over the Christmas break.

The survey resumed on 18 March 1996 after completing part of the Clarence Richmond airborne geophysical survey (Mitchell, 1998), which was delayed due to unsuitable ground conditions for satisfactory gamma-ray spectrometer data to be acquired. The Corona and Fowlers Gap survey was finally completed on 8 April 1996.

The first calibration flight to compensate for the magnetic field of the aircraft using an automatic aeromagnetic digital compensator was flown on 12 September 1995 during the Frome survey after an aircraft service. Further calibration flights were undertaken on 20 November 1995 after an aircraft service, upon resumption of the survey on 18 March 1996 and on 4 April 1996 after an aircraft service. Appendix B summarises flying days and production kilometres flown.

## **(ii) Survey Aircraft and Field Crew**

### **(a) Aircraft**

Aero Commander 500 S "Shrike", VH-BGE

### **(b) Field Crew**

Party Leaders:	Murray Richardson	12 September to 11 December 1995
	Ross Brodie	18 March to 8 April 1996
Technicians:	David Pownall	12 September to 31 October 1995
		18 March to 4 April 1996
	Trevor Dalziell	30 October to 11 December 1995
Operators:	Selwyn Wilcox	12 September to 11 December 1995
		18 March to 4 April 1996
	Lars Rickardsson	12 September to 11 December 1995
		18 March to 4 April 1996
Pilots:	Capt. John Biffin	(Skywest Aviation)
	Capt. Murray Terwey	(Skywest Aviation)
	Capt. Mark Bourguignon	(Skywest Aviation)

## **3. SURVEY EQUIPMENT**

### **(i) Major Equipment**

Magnetometer:	Geometrics G833 helium magnetometer
Compensator:	RMS Instruments Automatic Aeromagnetic Digital Compensator
Gamma-ray spectrometer:	Geometrics gamma-ray spectrometer consisting of a GR820 spectrum processor, and two DET1024 spectrometer crystal detectors (33.56 litres total)
Altimeter:	Collins ALT-50 radar altimeter
Barometer:	AGSO digital – Setra sensor
Thermometer:	AGSO digital – RS sensor
Navigation:	Ashtech XII "Ranger" GPS receivers

	Ashtech "Ranger" differential processing software
	Real time differential GPS link via Philips 8010 radio transceivers (1995 only)
	Fugro OmniSTAR Plus real time differential GPS base station system (1996 only)
Doppler:	Racal (Decca) doppler antenna (80561 CAD) Sperry C 14 D compass
Video:	National colour video camera (WV CL 302E) National VCR (NV 180) National LCD TV (TCL 3A) National Time Date Generator (WJ 810)
Acquisition hardware:	HP-A400 computer, HP9122 720 Kb 3.5 inch dual floppy disc drive, HP Thinkjet printer, Contura Notebook and 120 Mb portable hard disc drive
Acquisition software:	AGSO-developed HP assembler language program

## **(ii) Navigation**

### **(a) GPS Navigation System**

Real time differential global positioning system (RT-DGPS) aircraft navigation was accomplished using Ashtech XII GPS receivers.

Aircraft navigation was carried out using an Ashtech XII global positioning system (GPS). A receiver in the aircraft received range data from satellites and differential corrections every second and calculated the aircraft's current latitude and longitude coordinates in the World Geodetic System 1984 (WGS84). The range data were recorded internally in the GPS receiver every five seconds.

In 1995, one receiver was set up as a base station in the old meteorological compound about 200 m west of AGSO's field office caravan at the Broken Hill airport. In 1996 the base station was set up on the airfield. The base station and aircraft receivers internally recorded range data every five seconds.

During the 1995 portion of the survey the base station receiver calculated and transmitted differential GPS corrections to the aircraft GPS receiver via a network of strategically placed radio transceivers in real time. During the 1996 portion of the survey the a Fugro OmniSTAR Plus base station system was utilised for real time differential GPS corrections. This system uses differential corrections, supplied by Fugro Starfix Pty. Ltd., which are transmitted via an Optus satellite link.

The real time differential corrections were applied by the aircraft receiver. The receiver then calculated the aircraft's latitude and longitude coordinates in the World Geodetic System 1984 (WGS84). The position was recorded on the aircraft acquisition system every second and was also used to provide the pilot with aircraft guidance information on an LCD display. The RT-DGPS method is described in Appendix C.

The internally recorded range data were post processed using Ashtech "Ranger" software at the end of each flying day. The error in position of the post processed flight path data is approximately five metres or less.

The position of the base station GPS receiver was accurately determined by differential GPS surveying using the "Round Hill" trig site, approximately 4 km northeast of Broken Hill, as a fixed reference point.

The determined base station GPS coordinates (WGS 84) were:

1995	Longitude	:	141° 27' 57.55041" E
	Latitude	:	32° 00' 00.02422" S
	Ellipsoidal height	:	295.7040 m
1996	Longitude	:	141° 27' 59.25927" E
	Latitude	:	32° 00' 06.33025" S
	Ellipsoidal height	:	293.667 m

(b) Doppler Navigation System

Doppler navigation data were used as a secondary navigation system on the aircraft and as a back-up for the main navigation system (GPS) and to infill gaps (<5 km) in the GPS data.

(c) Video Flight Path Recording

The aircraft's flight path was recorded on a VHS video system consisting of a National colour video camera with a wide angle lens, a National VCR and a National LCD TV. This system was also used for locating start and end positions for the gamma-ray spectrometer test line.

**(iii) Magnetometer**

A Geometrics G833 helium magnetometer, with the sensor mounted in a boom attached to the rear of the aircraft, was used for the survey. The specifications of the magnetometer are summarised in Appendix D.

The recorded total magnetic field data were compensated in real time using an RMS Instruments automatic aeromagnetic digital compensator (AADC). The AADC compensates for the effects of aircraft motion and heading. The specifications of the AADC are summarised in Appendix E. Compensation procedures are described in Chapter 4.

The AADC applies a low pass filter to the total magnetic field intensity data using a second order 0.9 Hz recursive Butterworth filter. The filtered compensated total magnetic field intensity data were recorded on the aircraft acquisition system.

**(iv) Gamma-ray Spectrometer**

An Exploranium gamma-ray spectrometer, incorporating two DET1024 crystal detectors with a total volume of 33.56 litres, was used. The crystal gains were controlled by an Exploranium GR820 spectrum processor. Appendix F summarises the specifications of the gamma-ray spectrometer components.

Two hundred and fifty six channels of data, between 0.0 MeV and 3.00 MeV, were recorded every second. These data were recorded on a portable hard disc via a communications link between the HP-A400 computer acquisition system and a Contura notebook computer.

Additionally, five windows of data were recorded once a second using the following window limits:

Total count	0.410 – 3.00 MeV
Potassium	1.370 – 1.570 MeV
Uranium	1.660 – 1.860 MeV
Thorium	2.410 – 2.810 MeV
Cosmic	3.00 MeV and above

Total count, potassium, uranium and thorium window counts were used for data checking during acquisition and the cosmic counts were used for cosmic background estimation and later data processing. A cumulative 256 channel spectrum between 0.0 MeV and 3.00 MeV was also recorded every 100 s. System live time (sample time - total dead time) was output with the data for later data processing.

**(v) Altimeter**

A Collins ALT-50 radar altimeter was used to measure ground clearance. The radar altimeter display indicates ground clearance from 0-2000 feet. The manufacturer's specifications claim  $\pm 2\%$  accuracy for the ALT-50 system.

**(vi) Barometer and Thermometer**

Atmospheric temperature and pressure were measured using a digital barometer (Setra sensor) and digital thermometer (RS sensor). The analogue output sensors were integrated into the data acquisition system via an analogue to digital converter. The sensors were factory calibrated and no AGSO calibrations were performed.

**(vii) Base Station Magnetometer**

Daily variations of the Earth's magnetic field were monitored using a Geometrics G833 helium magnetometer, the specifications of which are given in Appendix G. The base station was set up in an area of shallow magnetic gradient, away from cultural influences and within telemetry range of AGSO's office caravan.

The magnetometer was connected to a laptop computer incorporating a GT100 universal counter card to calculate the magnetic field values, and a Magellan OEM GPS module to enable synchronisation of the diurnal data with aircraft data. The magnetic values were sampled and recorded every 0.1 s. These 0.1 s data were later used for diurnal corrections during data processing.

Data from the base station were also telemetered back to the AGSO's field office caravan every 5 s for real time display and recording on a laptop computer. The telemetry system used AGSO-built modems incorporating Phillips 828 UHF mobile radiotelephone transmit boards at a frequency of 471.8 MHz.

The base station system and acquisition software were developed in-house at AGSO.

**(viii) Aircraft Data Acquisition**

The aircraft acquisition program and system were run using a HP-A400 computer with data recorded on 3.5 inch floppy discs using a HP9122 720 Kb disc drive. The 1 s multichannel spectra were recorded on a portable hard disk linked to the acquisition system through a notebook computer.

This acquisition program was developed in-house at AGSO. The data were displayed in real time in the aircraft in analogue form on a HP Thinkjet printer. A schematic diagram of the aircraft's acquisition system is shown in Appendix H.

#### **4. CALIBRATION**

##### **(i) Compensation for the Magnetic Field of the Aircraft**

Compensation flights were flown in an area of low magnetic gradient prior to the start of the survey and after each aircraft service or change of aircraft alternators. The flights were flown at an altitude of 2800 m above sea level, approximately 90 km northeast of Broken Hill over an area between 142° 01' to 142° 10' E and 31° 13' to 31° 22' S.

The compensation comprises a series of rolls ( $\pm 10^\circ$ ), pitches ( $\pm 5^\circ$ ) and yaws ( $\pm 5^\circ$ ) in the four cardinal headings to enable the AADC to calculate correction coefficients needed to remove aircraft manoeuvre noise. Each manoeuvre component was of 30 s duration.

The compensation manoeuvres were repeated after calculation of the coefficients to check the compensation quality. Prior to compensation the peak-to-peak manoeuvre noise was generally 1 nT. Peak-to-peak noise during repeat manoeuvres after the compensation was 0.20 nT or less. On normal survey flights, noise levels from all sources were generally less than 0.15 nT peak-to-peak.

The AADC calculates basic statistics, which reflect the degree of merit of the compensation. These include the standard deviation of the recorded data without corrections applied, the standard deviation with the corrections applied, the improvement ratio (the ratio of the standard deviation of the recorded data without and with the corrections applied) and the vector norm (the degree of difficulty in calculating the corrections). Appendix I lists these statistics, the dates the compensations were performed and the period over which each compensation was used.

##### **(ii) Gamma-ray Spectrometer Calibration**

The GR820 spectrum processor uses a sophisticated automatic control method to maintain crystal alignment while stabilising on naturally occurring isotopes (typically potassium or thorium). During operation, the system continuously monitors and accumulates separate spectra for each crystal detector. When the confidence level for the selected stabilisation peak (potassium or thorium) is exceeded, the peak channel of this isotope is computed, compared to the correct peak location, and the gain is then corrected.

Crystal alignment checks were performed (using a small thorium source) at the start of each day prior to production flying. Adjustments were made to ensure the spectrometer stabilised on the thorium 2.62 MeV photopeak at channel 206. The resolution of the gamma-ray spectrometer system was measured using the full width at half maximum method (IAEA, 1991). The resolution of the thorium peak was between 5.4% and 5.7%.

Gamma-ray spectrometric test lines were flown at the beginning and end of each production flight. These lines were flown at survey altitude along a dirt road and lasted 100 s or approximately 7 km. The test line was located approximately 20 km northwest

of Broken Hill and is shown in Appendix J. Background estimates for the low level test lines were obtained using a full spectrum method (Minty 1992).

After each flight, statistics were calculated from data recorded between fixed reference points, observed on video, along the test line. These statistics were calculated for the total count channel, recorded in spreadsheet form and compared to the preceding flights in order to detect any irregularities. In particular, the percentage difference between the average background corrected total count channel counts for each test line and the running average of all previously flown test lines was analysed. This value did not exceed 8.0% for any test line, well inside a 15% variation, which was considered acceptable.

## **5. DATA PROCESSING**

Flight path recovery, data checking and editing, and preliminary gridding and imaging were performed at the survey base using the AGSO developed ARGUS processing system as well as the INTREPID data processing system. Final magnetic, gamma-ray spectrometric and digital elevation model data processing were carried out in Canberra using the INTREPID data processing system.

### **(i) Data Checking and Editing**

Data recorded on the aircraft acquisition system were transferred on a flight by flight basis to the hard disk of a Compaq SLT386s/20 computer. This computer was networked to a Scorpion 10/20 Sparcstation and all aircraft data were transferred to the Scorpion hard disk to be edited for missing values, noise, spikes or steps using the ARGUS and INTREPID processing systems. All the recorded data were displayed for each survey line and any errors were interactively corrected. Anomalies arising from cultural influences, such as drilling rigs, sheds, houses and fences, were usually not edited out. They were edited out if they caused severe noise or caused the magnetometer to loose lock.

### **(ii) Flight Path Recovery**

The range data, which were recorded internally every 5 s on both GPS receivers, were post-processed daily in the field using "Ranger" – an Ashtech proprietary program. "Ranger" calculates the corrected flight path (longitude, latitude and height) relative to the World Geodetic System 1984 (WGS84) reference ellipsoid.

At the end of each flying day the corrected longitude and latitude data calculated at 5 s intervals by "Ranger" were used to correct the GPS data which were recorded every 1 s on the aircraft acquisition system. As well as the standard "Ranger" corrections, other acquisition system specific corrections were applied. Position data were retained in the WGS84 coordinate system. The WGS84 is defined in Appendix K. Taking the accuracy of the navigation data into account, the WGS84 system can be considered to be the same as the Geocentric Datum of Australia (GDA) for the survey data. For a given position in the survey area, the GDA coordinate will appear to lie approximately 205 m northeast of the corresponding Australian Geodetic Datum (AGD) coordinate. That is to convert from GDA to AGD, coordinates must be moved 120 m West and 166 m South.

The full post-processing correction procedure applied to the position data is described in Appendix L and is outlined below;

- (a) Position calculation delay correction.
- (b) Fiducial synchronisation correction.
- (c) "Ranger" corrections.
- (d) Low pass filter.
- (e) Reference navigation data to position of magnetometer sensor.
- (f) Doppler infill of short gaps.

The fully corrected flight path was plotted each day to check the position of survey lines and their spacing. Navigation reflies were determined by the following criteria:

Line Spacing	Across Track Deviation	Distance along line
100 m	40 m	greater than 3 km
200 m	40 m	greater than 3 km

Where both the across track deviation and along line distance were exceeded that portion of the survey line was re flown. This occurred on 27 survey lines.

### **(iii) Magnetic Data Processing**

Compensated checked and edited magnetic data were read into an INTREPID database which included the navigation data. Diurnal variation corrections were applied. The 0.1 s data recorded from the G833 helium base station magnetometer were used for the diurnal variation correction. These 0.1 s data were low pass filtered prior to the correction being applied. The filter used removed high frequency variations with periods less than 1 minute.

The IGRF 1990 geomagnetic reference field, updated to 1 January 1996 and for an altitude of 260 m above sea level (estimated to be the mean survey altitude) was then subtracted from the data. The IGRF was calculated from the coefficients defined by the IAGA (1991). All magnetic values were adjusted by a constant so that the average residual magnetic field value was approximately 5000 nT.

The data were levelled using standard tie line levelling procedures. Luyendyk (1997) describes the procedure involved in the tie line levelling method in more detail. The steps involved in the tie line levelling were as follows.

- (a) Tie line 460 was chosen as the reference tie.
- (b) All other ties were levelled to tie line 460 using degree three piecewise polynomial adjustments.
- (c) Lines were adjusted on a flight by flight basis to minimise the differences at line/tie crossover points. Degree two piecewise polynomial adjustments were used.
- (d) Finally the lines were individually adjusted to minimise crossover differences, using degree two piecewise polynomial adjustments.

The data were micro-levelled in two passes using the technique described by Minty (1991). Filter characteristics used are described below:

Pass 1: Applied to all data.

- (a) Low pass filter in the flight line direction with a cut-off wavelength of 1500 m.
- (b) High pass filter in the tie line direction with a cut-off wavelength of 400 m.
- (c) Correction strings were low pass filtered with a cut-off wavelength of 100 m before being applied to the line data and were constrained to lie within the range  $\pm 5$  nT (99% of these corrections fell in the range  $\pm 0.5$  nT).

Pass 2: Only applied to data covering the 100 m line spacing area.

- (a) Low pass filter in the flight line direction with a cut-off wavelength of 600 m.
- (b) High pass filter in the tie line direction with a cut-off wavelength of 200 m.
- (c) Correction strings were low pass filtered with a cut-off wavelength of 100 m before being applied to the line data and were constrained to lie within the range  $\pm 12$  nT (98% of these corrections fell in the range  $\pm 2.6$  nT).

The micro-levelled data were gridded using the minimum curvature technique described by Briggs (1974), employing a 20 metre (0.75") grid cell size.

#### **(iv) Gamma-ray Spectrometer Data Processing.**

A combination of full-spectrum and 3-channel processing methods were used to correct the gamma-ray spectrometric data. The smoothed spectra were lifetime corrected, energy calibrated and background corrected. The spectra were then summed over the conventional 4-channel windows (IAEA, 1991), for subsequent stripping and height correction as described below.

The energy calibration was performed by using the positions of prominent photopeaks in the accumulated line spectrum (the sum of all individual spectrum for the line) to obtain an estimate of the base energy (energy at channel one in keV) and the gain (channel width in keV). These parameters were then used to correct each spectrum in the line by resampling each channel over its correct energy range.

The three components of background were determined as follows.

##### **(a) Aircraft and Cosmic Background**

Aircraft and cosmic spectra for the AGSO aircraft were determined from high altitude calibration flights using the procedure described by Minty and Richardson (1989).

##### **(b) Atmospheric Radon Background**

A full spectrum method (Minty, 1998) was used to remove radon background. The method is based on the assumption that the observed spectrum (after correcting for aircraft and cosmic background) is the linear sum of the spectra due to K, U, and Th in the ground and atmospheric radon. Since the shapes of these spectra can be determined through suitable calibrations, the atmospheric radon contribution to the observed spectrum can be estimated.

The energy-calibrated and background-corrected spectra were then summed over the conventional 4-channel windows recommended by the IAEA (IAEA, 1991). Stripping (channel interaction correction) to correct for Compton scattering were then applied to the K, U, and Th window count rates. Stripping ratios for the AGSO system were determined using the procedure recommended by the International Atomic Energy Agency (IAEA, 1991). The corrections were applied as follows:

$$\begin{aligned} N_{\text{TH(corrected)}} &= N_{\text{TH}} \\ N_{\text{U(corrected)}} &= N_{\text{U}} - A \times N_{\text{TH(corrected)}} \\ N_{\text{K(corrected)}} &= N_{\text{K}} - B \times N_{\text{TH}} - C \times N_{\text{U(corrected)}} \end{aligned}$$

where

$$\begin{aligned} N_{\text{TH}} &= \text{counts in the thorium channel} \\ N_{\text{U}} &= \text{counts in the uranium channel} \\ N_{\text{K}} &= \text{Counts in the potassium channel} \\ A &= 0.30987 + 0.00049 \times \text{height} \\ B &= 0.38308 + 0.00065 \times \text{height} \\ C &= 0.83815 + 0.00069 \times \text{height} \end{aligned}$$

The data were then corrected for height attenuation and reduced to a nominal flying height of 60 m. Where the aircraft attained a height of 250 m or higher above the ground gamma-ray spectrometric data have been set to undefined. Height attenuation corrections were made using the following formula:

$$N_{\text{corrected}} = N_{\text{uncorrected}} e^{-u(H-h)}$$

where

$$\begin{aligned} N_{\text{corrected}} &= \text{corrected counts} \\ N_{\text{uncorrected}} &= \text{uncorrected counts} \\ H &= \text{nominal flying height} \\ h &= \text{measured flying height} \\ u &= \text{attenuation coefficient} \end{aligned}$$

Attenuation coefficients for each channel are given below:

$$\begin{aligned} u_{\text{total count}} &= 0.00785 \\ u_{\text{potassium}} &= 0.00943 \\ u_{\text{uranium}} &= 0.01150 \\ u_{\text{thorium}} &= 0.00747 \end{aligned}$$

Before any further processing of the gamma-ray spectrometric data the associated position data were corrected for a parallax error of -9.03 m (i.e. shifted toward the front of the aircraft by 9.03 m) to account for the difference between the position of the spectrometer crystals and the position data reference point (at the magnetometer sensor).

The total count, potassium and thorium data did not require tie line levelling. Uranium data were tie line levelled in much the same way as the magnetic data. However prior to sampling the crossover points, a 5 point convolution filter with a cut-off wavelength of 350 m was passed over the data. Note that these filtered data were only used for the crossover analysis and the final point located data have not been filtered.

The steps involved in tie line levelling of uranium data were as follows:

- (a) Tie line 420 was chosen as a reference tie.
- (b) All other ties were levelled to the reference tie line using degree one piecewise polynomial adjustments.
- (c) Lines were adjusted on a flight by flight basis using degree one piecewise polynomial adjustments to minimise the differences at line/tie crossover points.
- (d) The lines were then individually adjusted to minimise crossover differences using degree one piecewise polynomial adjustments.

All gamma-ray spectrometric data were micro-levelled in using the technique described by Minty (1991). Filter characteristics are described below:

- (a) Low pass filter in the flight line direction with a cut-off wavelength of 2000 m (5000 m for uranium).
- (b) High pass filter in the tie line direction with a cut-off wavelength of 400 m (800 m for uranium).
- (c) Correction strings were low pass filtered with a cut-off wavelength of 200 m before being applied to the line data and were constrained to lie within the following ranges;
  - $\pm 300$  cps for total count (90% of adjustments were less than  $\pm 75$  cps)
  - $\pm 15$  cps for potassium (90% of adjustments were less than  $\pm 6$  cps)
  - $\pm 7.5$  cps for uranium (90% of adjustments were less than  $\pm 2.5$  cps)
  - $\pm 15$  cps for thorium (90% of adjustments were less than  $\pm 3.7$  cps)

All channels were gridded to a 20 metre (0.75") cell size using Brigg's minimum curvature technique.

**(v) Digital Elevation Model Data Processing.**

As described in Chapter 5 – Section (ii), range data recorded internally every 5 s on both GPS receivers were post-processed on a daily basis using "Ranger" - an Ashtech proprietary program. "Ranger" calculates the position of aircraft GPS receiver's antenna, including longitude, latitude and height relative to the WGS84 reference ellipsoid for each set of range data (every 5 s).

As in the case of the longitude and latitude data, the following acquisition system specific corrections, which are described in Appendix L, are applied to the height data:

- (a) Position calculation delay correction.
- (b) Fiducial synchronisation correction.

The corrected height data, which are relative to the WGS84 reference ellipsoid, are then linearly interpolated to 1 s samples (70 m) and are merged with the longitude and latitude data.

A radar altimeter provided the aircraft's ground clearance, the altimeter data being sampled every one second.

The raw ground elevation data were then calculated as the difference between the height of the aircraft above the ellipsoid and the height of the aircraft above the ground. These raw elevation data are calculated every one second (70 m) are relative to the WGS84 reference ellipsoid - the ellipsoid being a horizontal datum.

Before any further processing of the digital elevation model data the associated position data were corrected for a parallax error of -11.4 m (i.e. shifted toward the front of the aircraft by 11.4 m) to account for the difference between the position of the GPS and radar altimeter antennae and the position data reference point (at the magnetometer sensor).

Elevation data were tie line levelled in much the same way as the magnetic data. The steps involved in tie line levelling were as follows:

- (a) Tie line 420 was chosen as a reference tie.
- (b) All other ties were levelled to the reference tie line using degree three piecewise polynomial adjustments.
- (c) Lines were adjusted on a flight by flight basis using degree one piecewise polynomial adjustments to minimise the differences at line/tie crossover points.
- (d) The lines were then individually adjusted to minimise crossover differences using degree three piecewise polynomial adjustments.

Elevation data were then micro-levelled in two passes using the technique described by Minty (1991). Filter characteristics are described below:

Pass 1: Applied to all data.

- (a) Low pass filter in the flight line direction with a cut-off wavelength of 3000 m.
- (b) High pass filter in the tie line direction with a cut-off wavelength of 800 m.
- (c) Correction strings were low pass filtered with a cut-off wavelength of 200 m before being applied to the line data and were constrained to lie within the range  $\pm 6$  m (98% of these corrections fell in the range  $\pm 0.75$  m).

Pass 2: Only applied to data covering 100 m line spacing area.

- (a) Low pass filter in the flight line direction with a cut-off wavelength of 1500 m.
- (b) High pass filter in the tie line direction with a cut-off wavelength of 400 m.
- (c) Correction strings were low pass filtered with a cut-off wavelength of 200 m before being applied to the line data and were constrained to lie within the range  $\pm 8$  m (95% of these corrections fell in the range  $\pm 2.1$  m).

The next step is to convert the heights relative to the WGS84 ellipsoid to heights relative to the geoid. The geoid, which is defined as "the equipotential surface of the gravity field which best approximates mean sea level", is usually chosen as the datum to which heights plotted on maps are referred. The height of the geoid above the WGS84 ellipsoid is called the geoid - ellipsoid separation or N value.

Geoid - ellipsoid separation information for the survey area were supplied by the Australian Surveying and Land Information Group (AUSLIG) in January 1996. The set of N values were supplied as a 10 minute of arc (approximately 18 km) grid. AUSLIG also provides a program "DINTER" which uses bilinear interpolation to calculate N values on a one minute of arc (approximately 1600 metre) grid.

These values were then imported into an INTREPID database and gridded using the INTREPID software package to a cell size of 15 seconds of arc (approximately 400 m). This grid of N values was used to calculate correction strings to be subtracted from the elevation data. The correction strings were low pass filtered with a cut-off wavelength of 500 m before being applied to the point-located elevation data.

The elevation data were then corrected to account for the vertical separation between the antenna of the aircraft's GPS receiver, on the roof of the aircraft, and radar altimeter on the belly of the aircraft. This antenna separation distance of 1.675 m was subtracted from the elevation data.

The accuracy of the position located height data is expected to be better than  $\pm 2$  metres. Relative precision from point to point along a flight line is expected to be better than  $\pm 1$  metre.

A comparison was made between third order gravity station heights and the elevation data. There were 203 gravity stations within 20 m of airborne sample points. At these 203 stations the elevation data were on average 4.14 m larger than the gravity station heights. The standard deviation of the differences between the elevation data and gravity station heights was 4.24 m. The 4.14 m discrepancy in heights may be due to an inaccuracy in the trig station height used in determining the GPS base station height.

The fully corrected elevation data were gridded using using ANUDEM46 (Hutchinson, 1988, 1989) employing a 20 metre (0.75") grid cell size.

**(vi) Final Products**

**(a) Standard AGSO geophysical maps**

An AGSO standard set of geophysical maps have been produced at scales of 1:100 000 1:50 000 and 1:25 000 for the entire survey area. Profile, flight path and contour maps were produced using the INTREPID software. The standard set of maps produced are shown in Appendix M.

**(b) Digital Data**

Final processed point-located data and grids were archived in the standard AGSO ARGUS format, on exabyte magnetic tape cartridges and compact discs, in ASCII format (Appendix N).

## 6. REFERENCES

- Briggs, I.C., 1974 - Machine contouring using minimum-curvature. *Geophysics*, **39**, 39-48.
- Grasty, R. L., 1975 - Uranium measurements by airborne gamma-ray spectrometry. *Geophysics*, **40**, 503-519.
- Hutchinson, M.F., 1988. - Calculation of hydrologically sound digital elevation models. Third International Symposium on Spatial Data Handling, Sydney. *International Geographical Union, Columbus*, 117-133.
- Hutchinson, M.F., 1989. - A new procedure for gridding elevation and stream line data with automatic removal of spurious pits. *Journal of Hydrology*, **106**, 211-232.
- International Association of Geomagnetism and Aeronomy, 1991 - Division V Working Group 8. International Geomagnetic Reference Field, 1991 Revision. *Journal of Geomagnetism and Geoelectricity*, **43**, 1007-1012.
- International Atomic Energy Agency, 1991 - Airborne Gamma Ray Spectrometer Surveying. *International Atomic Energy Agency Technical Reports Series Number 323*, IAEA Vienna.
- Luyendyk, A.P.J., 1997 - Processing of airborne magnetic data. *AGSO Journal of Geology and Geophysics*, **17** (2), 31-38.
- Milligan, P. R., Morse, M. P., and Rajagopalan, S., 1992 - Pixel map preparation using the HSV colour model. *Exploration Geophysics*, **23**, 219-224.
- Minty, B. R. S., Morse, M. P., and Richardson, L. M., 1990 - Portable calibration sources for airborne gamma-ray spectrometers. *Exploration Geophysics*, **21**, 187-195.
- Minty, B. R. S., 1991 - Simple micro-levelling for aeromagnetic data. *Exploration Geophysics*, **22**, 591-592.
- Minty, B. R. S., 1992 - Airborne gamma-ray spectrometric background estimation using full spectrum analysis. *Geophysics*, **57**, 279-287.
- Minty, B. R. S., and Richardson, L. M., 1989 - Calibration of the BMR airborne gamma-ray spectrometer upward-looking detector, February 1989. *Bureau of Mineral Resources, Australia, Record 1989/8*.
- Minty, B. R. S., 1998 - Multichannel models for the estimation of radon background in airborne gamma-ray spectrometry. *Geophysics*, **63** (6), 1986-1996.
- Richardson, L. M., 1996 - Frome (Frome and Southern Callabonna 1:250 000 Sheet Areas) Airborne Geophysical Survey, 1995 - Operations Report. *Australian Geological Survey Organisation, Australia, Record 1996/20*.
- Mitchell, J. N., and Minty, B. R. S., 1998 - Clarence Richmond, Maclean, Tweed Heads and Eastern Grafton 1:250 000 Sheet Areas, Airborne Geophysical Survey, 1997 - Operations Report. *Australian Geological Survey Organisation, Australia, Record 1998/27*.

# Appendix A-1

## Survey Area

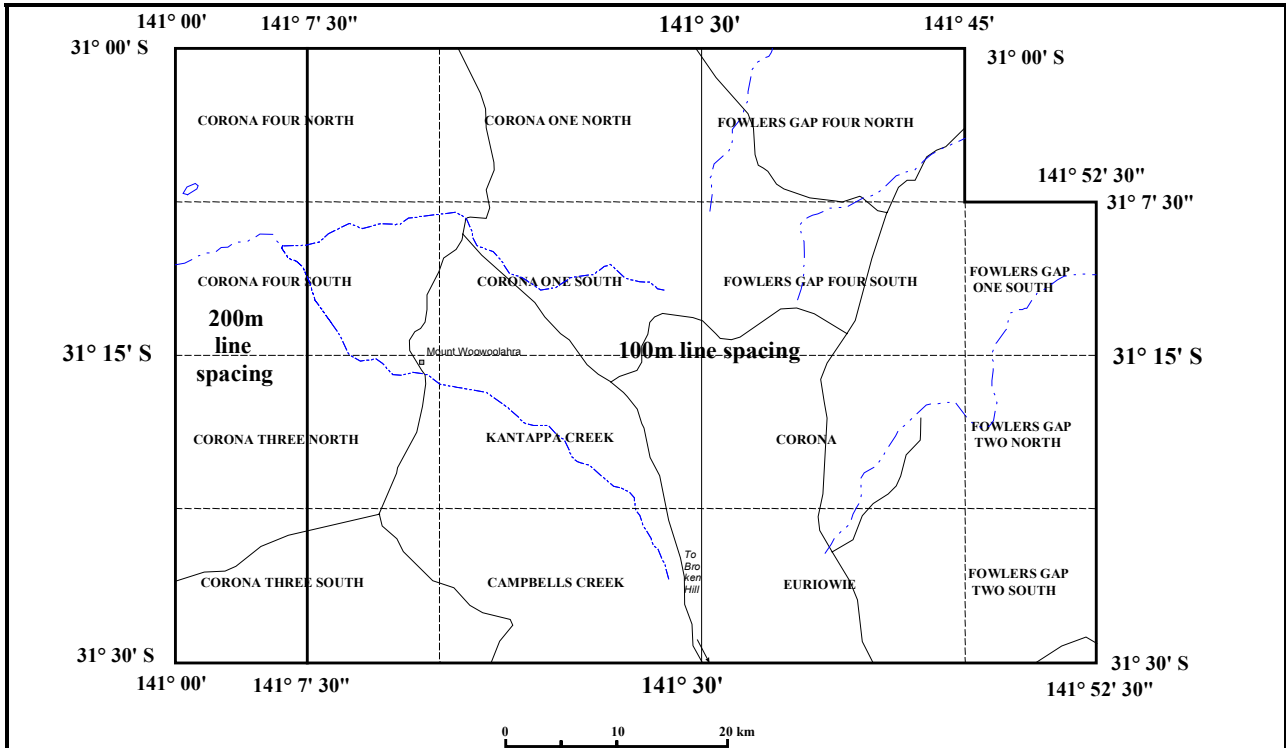

### CORONA/FOWLERS GAP NSW 1995/1996 SURVEY

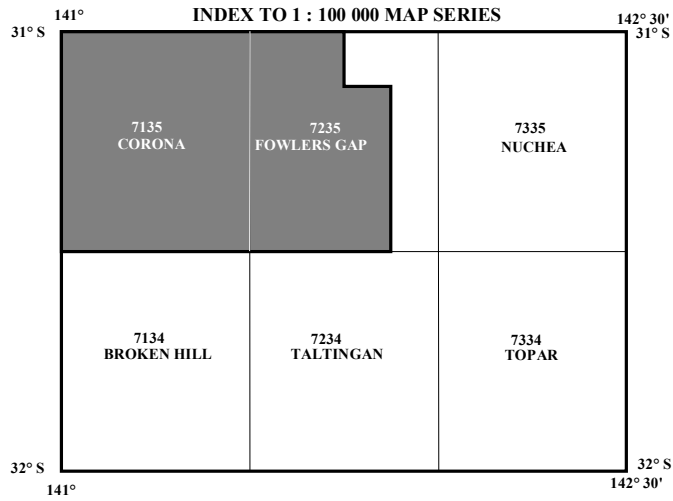

## Appendix B-1

### Flying Dates and Production Kilometres Flown

Date	Flight Number	Comments	Line / Tie Kilometres
12/09/95	390	Compensation flight (Frome and Callabonna survey) Operating on Frome and Callabonna survey	0
16/09/95	396	Operations normal	785
16/09/95	397	Operations normal	715
17/09/95	398	Operations normal	885
18/09/95	399	Operations normal	895
18/09/95	400	Operations normal	890
19/09/95	401	Operations normal	555
19/09/95	402	Operations normal	735
20/09/95	403	Operations normal	585
20/09/95	404	Operations normal	360
21/09/95	405	Operations normal	885
22/09/95	406	Operations normal	835
23/09/95	407	Operations normal	859
25/09/95	409	Operations normal	427
26/09/95	410	Operations normal	855
26/09/95	411	Operations normal	985
27/09/95	412	Operations normal	945
27/09/95	413	Operations normal	840
28/09/95	414	Operations normal	870
28/09/95	415	Operations normal Operating on Frome and Callabonna survey	935
11/10/95	429	Operations normal	305
11/10/95	430	Operations normal	505
12/10/95	432	Operations normal Operating on Frome and Callabonna survey	170
20/11/95	455	Compensation flight (Frome and Callabonna survey) Operating on Frome and Callabonna survey	0
25/11/95	467	Part of flight 466 on Frome and Callabonna survey	58
25/11/95	468	Operations normal	673
27/11/95	469	Operations normal	865
27/11/95	470	Operations normal	335
28/11/95	471	Operations normal	785
29/11/95	472	Operations normal	810
29/11/95	473	Operations normal	725
30/11/95	474	Operations normal	835
30/11/95	475	Operations normal	800
1/12/95	476	Operations normal	795
1/12/95	477	Operations normal	725
2/12/95	478	Flight abandoned due faulty navigation display	0
2/12/95	479	Operations normal	725
3/12/95	480	Operations normal	850
4/12/95	481	Operations normal	810
4/12/95	482	Operations normal	905
5/12/95	483	Operations normal	895
5/12/95	484	Operations normal	485
6/12/95	485	Reflies	0
11/12/95		Ferry Broken Hill to Parkes en-route Canberra Christmas Break and Clarence Richmond survey	0
15/03/96		Ferry Lismore to Broken Hill for resumption of survey	0
18/03/96	131	Compensation and survey line	75
19/03/96	132	Operations normal	710
19/03/96	133	Operations normal	750
20/03/96	134	Operations normal	530
21/03/96	135	Operations normal	745

## Appendix B-2

21/03/96	136	Operations normal	745
22/03/96	137	Operations normal	825
22/03/96	138	Operations normal	785
23/03/96	139	Operations normal	670
23/03/96	140	Operations normal	755
25/03/96	141	Operations normal	745
25/03/96	142	Operations normal	730
26/03/96	143	Operations normal	695
26/03/96	144	Operations normal	820
27/03/96	145	Operations normal	855
27/03/96	146	Operations normal	790
28/03/96	147	Operations normal	760
28/03/96	148	Operations normal	865
29/03/96	149	Operations normal	815
29/03/96	150	Operations normal	740
30/03/96	151	Operations normal	785
30/03/96		Ferry Broken Hill to Melbourne for aircraft service	0
3/04/96		Return ferry from Melbourne	0
4/04/96	152	Compensation	145
4/04/96	153	Operations normal	835
5/04/96	154	Operations normal	875
5/04/96	155	Operations normal	815
6/04/96	156	Operations normal	805
6/04/96	157	Operations normal	615
8/04/96	158	Operations normal	745
8/04/96	159	Reflies	0
			47922

## Appendix B-3

### SUMMARY

Total line kilometres flown	47,920
Productive flights	65
Unproductive flights	9
Abandoned flights (productive or not)	1
Total flights in survey	75
Unproductive flights consisted of:	
Aircraft ferries	4
Compensation flights	2
Navigation refly flights	2
Abandoned flights	1
Abandoned flights due to:	
Equipment failure	1

## Appendix C-1

### Real Time Differential GPS

Real time differential GPS navigation is a method used to improve navigation accuracy. Line tracking using this method is more precise than by the single GPS receiver method thus allowing a pilot to fly an aircraft at line spacings of 100 m.

The navigation equipment used for this survey consisted of two Ashtech XII GPS receivers; one in a known position in the old meteorological compound about 200 m west of AGSO's field office caravan (base) the Broken Hill airport, and the other in the aircraft. The two identical GPS receivers were configured to run in differential mode.

The base station GPS calculated satellite range corrections, which were transmitted to the aircraft by a UHF radio link. The base radio transmitter was a Philips PRM 8010 UHF radio, transmitting at 5 watts power through a UHF collinear antenna mounted about 5 meters above ground level.

The radio in the aircraft was a Philips PRM 8030 transceiver with a "voting" facility, which enables the receiver to search out and lock onto the strongest signal available. The receiving antenna in the aircraft was a ground-plane independent type, mounted on the top of the tail.

To extend the range of operation, a repeater station for the telemetry system were used incorporating a pair of Philips PRM 8010 radios. The receiving antenna for the repeater was a nine element Yagi aimed at the base transmitter, while the transmitting antenna was a collinear type mounted about 5 m above the ground. The repeater was situated at Corona trig station some 77 km north north-east of the base station transmitter and at approximately 435 m asl.

The transmission frequencies for the network were:

Tx from base station.....471.650 MHz.

Tx from Corona repeater.....494.825 MHz.

The modems used to interface between the GPS receivers and the radios at the base station and in the aircraft were AGSO designed units incorporating TCM3105 chips operating at 1200 baud.

## Appendix D-1

### Specifications – G833 Helium Magnetometer

Operating range:	20,000 to 95,000 nT
Temperature:	-20 to +50 °C
Sensitivity:	0.0032 nT/root Hz RMS
Bandwidth:	350 Hz (-3 dB point)
Loop scan rate:	1000 cycles/second
Input power:	28 V DC, 6 A max
Output signal:	At Helium gyromagnetic frequency, approximately 28.02468 Hz/nT. 3 volts peak to peak
Dimensions:	Sensor cell - 80 mm diameter x 145 mm length Scan processor - 270 x 120 x 85 mm Control panel - 48.26 cm rack mount
Weight:	Approximately 6 kg

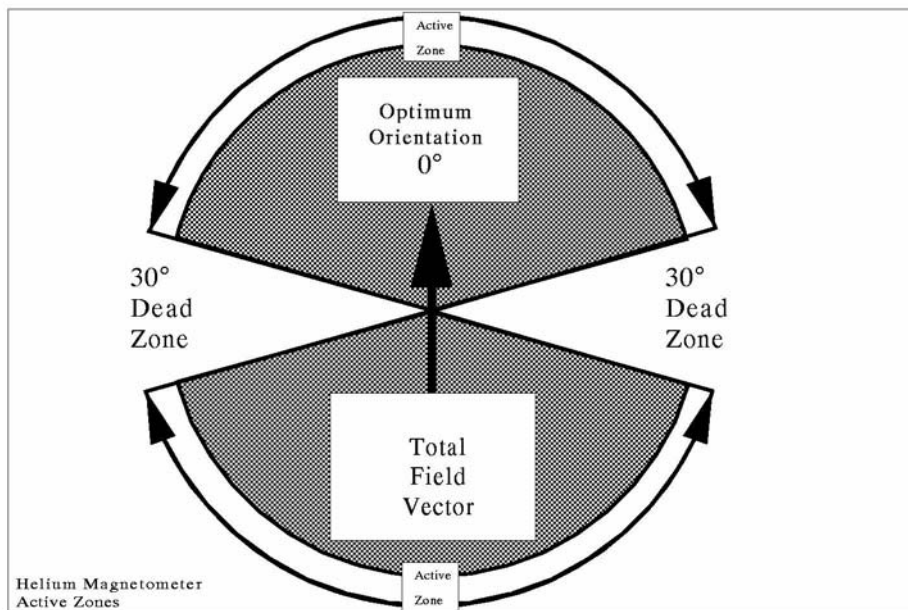

## Appendix E-1

### Specifications – RMS Instruments Automatic Aeromagnetic Digital Compensator

Inputs:	one or two high sensitivity magnetometers of optical absorption type
Input frequency range:	70 kHz – 350 kHz – Cs sensor 140 kHz – 700 kHz – K sensor 560 kHz – 2800 kHz – He sensor 850 Hz – 4260 Hz – Overhauser
Magnetic field range:	20,000 nT – 100,000 nT
Resolution:	1 pT (picotesla)
Compensation procedure:	improvement ratio 10 – 20 (typical for total field) improvement ratio 20 – 100 (typical for gradient)
Accuracy of compensation:	0.35 nT standard deviation for the entire aircraft flight envelope in the bandwidth 0 – 1 Hz typical
Data output rate:	10 Hz
System frequency response:	0 – 0.9 Hz
Internal system noise:	less than 2 pT (standard deviation in the bandwidth 0– 1 Hz)
Duration of calibration flight:	5 – 8 minutes typical
Vector magnetometer:	Develco Model 9202–02 (3-axis fluxgate)
Microcomputer:	SBC-11/21 Plus (DEC) Front End LSI–11/73(DEC) Main CPU
Keyboard:	limited alphanumeric
Display:	green fluorescent, 80 character self scan panel
Outputs	serial data communication port RS232C – max. rate 19.2 K Baud parallel output port:– 16 bit with full handshaking (DRV11–J) (optional)
Power:	28 ± 4 VDC 5A, 150 W (for single magnetometer) 7A, 196 W (for gradiometer system)
Environmental:	Operating temperature: 0°C to 50°C Storage temperature -20°C to 55°C Relative humidity 0–99%, non-condensing Altitude 0–6000 m
Physical data:	console dimensions: 483 x 178 x 440 mm console weight: 12.5 kg power supply dimensions: 225 x 180 x 220 mm power supply weight: 5.5 kg

## Appendix F-1

### Specifications – GR820 Spectrometer System

#### A. Detector Controller

- Maximum number of crystals – 16. Each crystal has individual pole–zero cancellation, semi–gaussian shaping and advanced base line restoration circuitry.
- Continuous, individual–crystal spectrum analysis ensures that optimum system stabilisation is achieved. Resolution is calculated by a sophisticated gaussian curve fitting algorithm to perform an accurate centroid analysis of the selected stabilisation peak.
- High energy cosmic pulses are accumulated in a separate channel.
- Accurate pile-up rejection for simultaneous pulses allows qualitative gamma–ray spectrum analysis almost independent of the system count rate. Special circuitry analyses for pulse pile–up and permits only detector signals from single events to be analysed. Simultaneous events in adjacent crystals are added to reduce the Compton effect.
- Residual pulse pile–up at 100,000 counts/sec are less than 2%.

#### B. Analogue to digital converter (ADC)

- 50 MHz Wilkinson ramp ADC.
- Linearity – integral – less than 0.2% ; – differential – less than 1%.
- Average system dead-time is less than 5 msec/pulse.
- Live–time channel records the actual system live–time. This data is output with the digital data which allows post correction for system dead–time to an accuracy of 0.1%.
- Number of channels – selection of 256 channels or 512 channel operation.
- Maximum number of counts/channel – 65,535 (16 bits).
- The lower threshold – manually selectable from channel 2 to channel 50 (20–500 keV).
- The upper threshold is set to 3 MeV. All pulses above 3 MeV are accumulated in the cosmic channel as a direct measure of cosmic ray activity.
- ADC offset set from the keyboard.
- The maximum input count rate is 100,000 cps.

#### C. System outputs

- Visual display – the front panel display is a 640x200 electroluminescent (EL) high contrast graphics display which allows full spectrum display, system set–up and various parameter monitoring functions. In the spectrum display mode, the region of interest and cursor may be viewed by channel number or directly in keV.
- The internal channel number to energy level (keV) conversion table compensates for non–linearity of the detector's light output.
- The front panel has a 21 button keyboard for easy operator control.
- The system's operation is fully menu driven.
- Digital outputs:
  - RS–232 port (1200 to 19200 baud).
  - IEEE-488 bus output – talk listen/talk only.
- Geometrics GR–800 output format.

## Appendix F-2

- Some system functions can be controlled remotely by an external computer via the RS–232 and the IEEE–488 digital ports.
- Analogue output:
  - 4 channels of ROI data can be selected for output on the analogue port. The outputs have 10 bit resolution (0–10V). Scaling can be set from the keyboard (100–50K counts/sec FSD) and output data may be raw or stripped using internally stored calibration constants. Analogue output wraps at FSD limits and is dead-time corrected.

### D. Miscellaneous

- Regions of interest (ROI): 8 ROIs can be selected. The upper and lower thresholds can be individually set over the entire spectrum range.
- The first 4 ROIs are available for digital and analogue output. The second 4 ROIs are available only for digital output on the RS–232 or the IEEE–488 ports.
- System resolution. Detector resolution is automatically computed for each (and summed crystals) during peak analysis and is displayed for operator monitoring when required. The summed down resolution is also output on the data stream.
- System test. At power on, a full system test of all internal handshaking is performed. Included in the testing is the lithium back-up battery, the system ram memory, display handshaking, the systems configuration (options installed), the selected detectors (checked via ADC analysis) and peripheral handshaking response.
- Configuration menus. The configuration menus allow the selection of the number of detectors in use, confidence levels for gain analysis, maximum crystal resolution levels for each detector (with operator warning if levels exceeded), output configurations for analogue and digital data and various special display/monitoring functions.
- Maintenance. A set of special menus allows the user to test and calibrate many system functions including system test, ADC offset, low level discriminator etc.
- Power: 28V – 1.25 amps

### E. Detectors

The crystals are housed in a specially designed hi–impact polystyrene cases using low background materials for minimum signal attenuation. Full thermal and internal shock protection allows the units to be directly mounted to the floor. A very low noise, high voltage power supply is housed in each pack so high voltage is not present in the connecting cables. A unique preamplifier with special processing for signal optimisation is used. The GPX–1024 has 4 crystals with a total volume of 16.78 litres

- Outputs: Individual BNC connectors output each crystal's signal separately
- Size: GPX–1024 : (73x51x30 cm)
- Weight: GPX–1024 : 84 kg
- Power: 28V @ 0.5A/crystal pack
- Temperature limitations
  - Closed pack: storage -40°C to +60°C, operation -40°C to +60°C
  - Open pack: not recommended
- Temperature gradient
  - Closed pack: -40°C to +50°C (instantaneous)
  - Open pack: a change of 1°C/hr

## Appendix G-1

### Specifications - G833 Helium Base Station Magnetometer

Operating range:	20,000 to 95,000 nT
Temperature:	-20 to +50 °C
Sensitivity:	0.0032 nT/root Hz RMS
Bandwidth:	350 Hz (-3 dB point)
Loop scan rate:	1000 cycles/second
Input power:	28 V DC, 6 A max
Output signal:	At Helium gyromagnetic frequency, approximately 28.02468 Hz/nT. 3 volts peak to peak
Dimensions:	Sensor cell - 80 mm diameter x 145 mm length Scan processor - 270 x 120 x 85 mm Control panel - 48.26 cm rack mount
Weight:	Approximately 6 kg

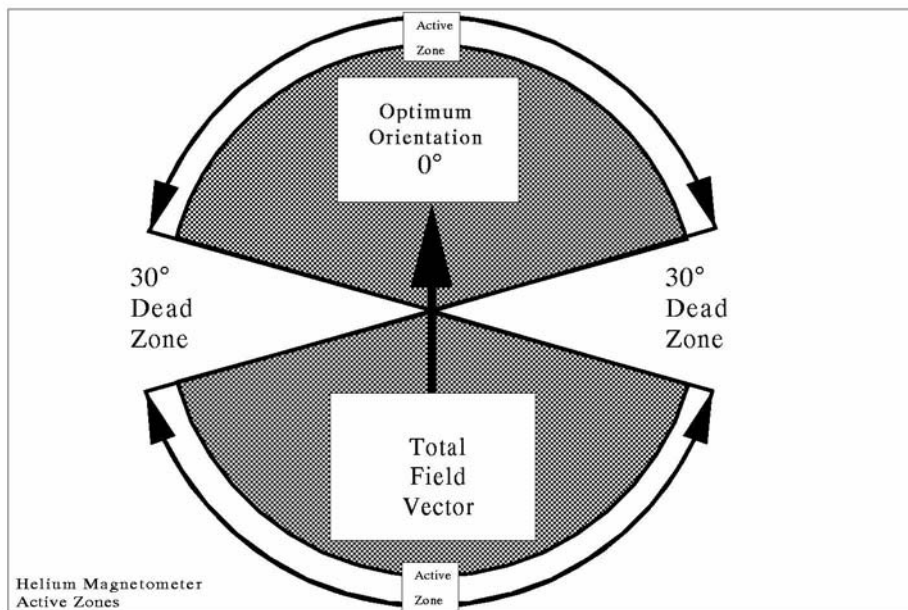

## Appendix G-2

### Specifications - Magellan OEM GPS Module

#### Operational characteristics

Position update rate:	1 s continuous (approximate)
Time to first fix:	
Warm start:	30 s (approximate) with almanac / date / time / initial position and ephemeris < 2 hours old
Cold start:	75 s 2D/3D (9 s approximate) with almanac / date / time / initial position
Autonomous start:	5 - 12 minutes typical (no almanac / ephemeris / date / time / initial position)

Position accuracy:	HDOP < 2, Cno > 47 db-Hz, 2D and with selective availability disabled
Horizontal position:	25 m RMS in 2D 30 m RMS in 3D
Vertical position:	50 m RMS

#### Electrical Characteristics:

Power:	
OEM/PS:	9 - 16 VDC 235 mA at 12 VDC typical, 250 mA max
OEM/5V:	5 VDC $\pm$ 0.2 VDC 170 mA
Interfaces:	RS232
Baud rates:	Jumper - selectable 1200,2400,4800, or 9600
Receiver type:	4 channels dedicated to tracking satellites 1 channel dedicated to tracking all other satellites

#### Firmware functions:

Timing:	Timing pulse ON/OFF UTC or GMT reference Time only mode Single satellite timing default all modes Hour, minute, second, day, month, year Status indicator Satellites in solution Signal quality
---------	--

OEM antenna:	Active Quadrifilar Helix
--------------	--------------------------

## Appendix G-3

### Specifications - GT100 Universal Counter

#### Input Characteristics

Channels A and B

Frequency Range:

DC to 100 MHz

Signal Operating Range:

+5 V to -5 V

Sensitivity:

Sinewave:

25 mV RMS DC to 20 MHz

50 mV RMS 20 MHz to 50 MHz

160 mV RMS 50 MHz to 100 MHz

Pulse:

450 mV peak-peak at 5 nsec pulse width

#### Measurement Functions:

Resolution:

$\pm \text{LSD} \pm \text{Freq} * 1.4 * \text{Trigger Error/Gate time Hz}$

Accuracy:

$\pm \text{Resolution} \pm \text{Time Base Error Hz}$

#### General:

Compatibility:

1 full size slot in any PC/XT, PC/AT or compatible, using DOS 3.0 or higher.

Compatible with any programming language.

Time pulse:

Standard 10 MHz Crystal Oscillator

Accuracy  $\pm 100$  ppm (0.01 %)

# Appendix H-1

## Aircraft Acquisition System

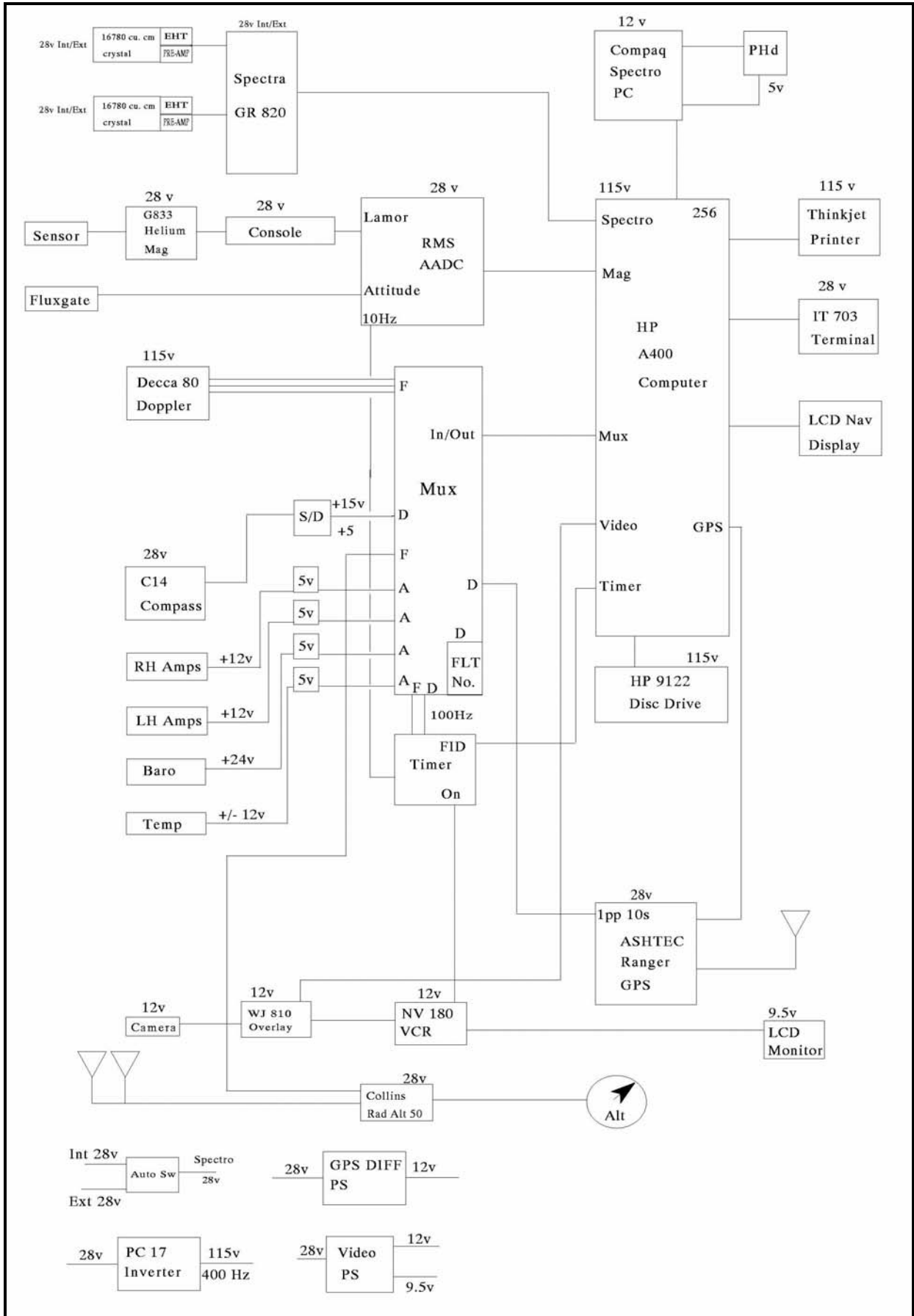

## Appendix I-1

### Compensation Results

#### Compensation 1

Date flown 12 September 1995  
Dates used 16 September to 12 October

Air conditioner off

$\sigma_u$	=	0.3898
$\sigma_c$	=	0.04028
$\lambda$	=	9.7
$v$	=	18.8

Air conditioner on

$\sigma_u$	=	0.3398
$\sigma_c$	=	0.04431
$\lambda$	=	7.7
$v$	=	18.1

#### Compensation 2

Date flown 20 November 1995  
Dates used 25 November to 6 December

Air conditioner off

$\sigma_u$	=	0.3553
$\sigma_c$	=	0.04854
$\lambda$	=	7.3
$v$	=	19.7

Air conditioner on

$\sigma_u$	=	0.4017
$\sigma_c$	=	0.05783
$\lambda$	=	7.0
$v$	=	21.0

#### Compensation 3

Date flown 18 March 1996  
Dates used 19 to 30 March

Air conditioner off

$\sigma_u$	=	0.6504
$\sigma_c$	=	0.03469
$\lambda$	=	18.6
$v$	=	23.2

Air conditioner on

$\sigma_u$	=	0.7887
$\sigma_c$	=	0.03435
$\lambda$	=	23.0
$v$	=	24.5

#### Compensation 4

Date flown 4 April 1996

## Appendix I-2

Dates used		4 to 8 April
Air conditioner off	$\sigma_u$	= 0.3978
	$\sigma_c$	= 0.03528
	$\lambda$	= 11.3
	$v$	= 22.5
Air conditioner on	$\sigma_u$	= 0.4103
	$\sigma_c$	= 0.07197
	$\lambda$	= 5.7
	$v$	= 23.4

$\sigma_u$  = standard deviation of data recorded during manoeuvres

$\sigma_c$  = standard deviation of data recorded during manoeuvres after compensation corrections have been applied

$\lambda$  = improvement ratio =  $\sigma_u / \sigma_c$

$v$  = vector norm, a measure of the degree of difficulty in calculating the coefficients

# Appendix J-1

## Gamma-ray Spectrometer Test Line Location

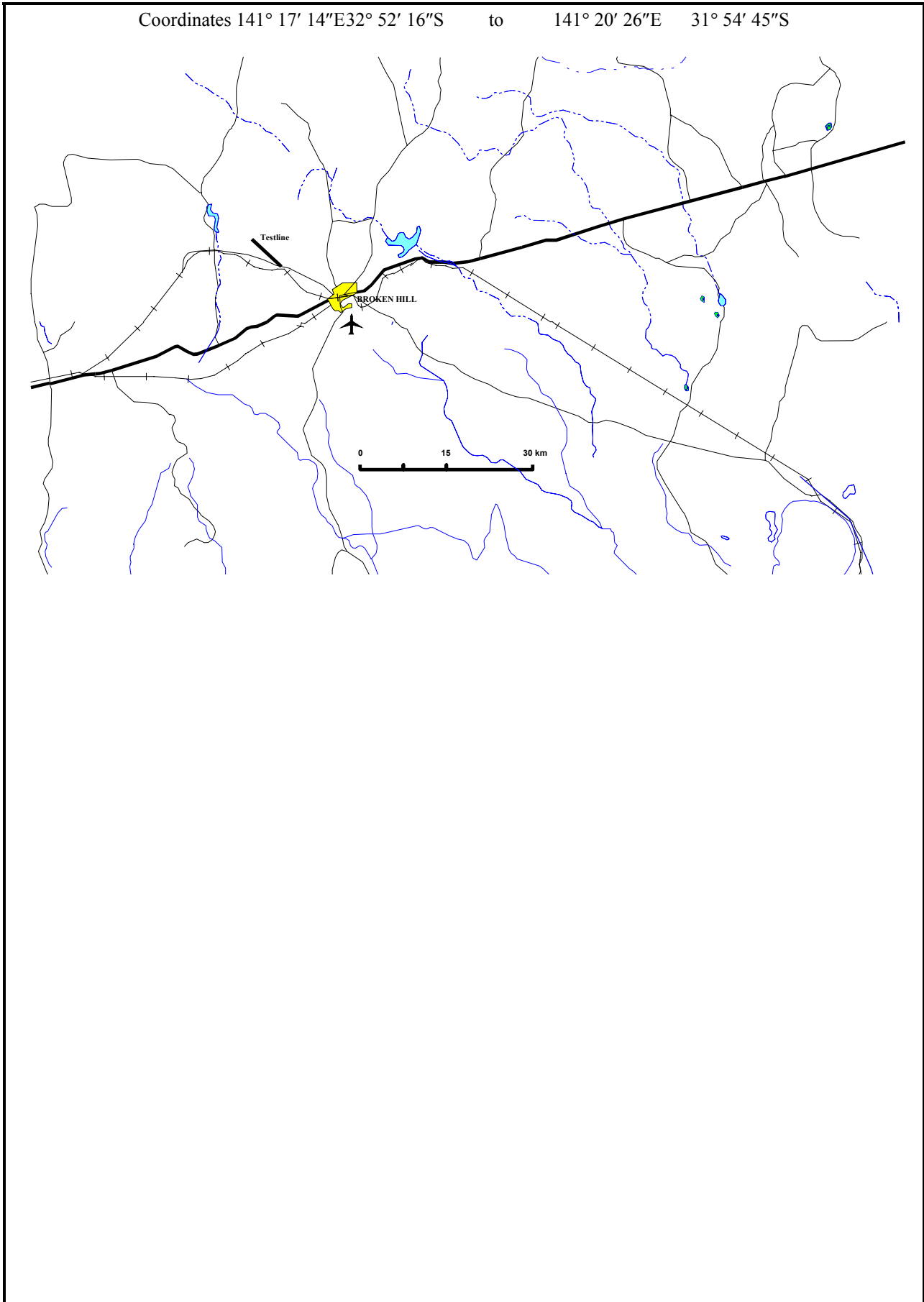

## Appendix K-1

### The World Geodetic System 1984 Datum

For geophysical surveys the real shape of the earth has to be considered. An ellipsoid of revolution around the earth's north-south axis approximates the earth's shape. This figure is called the spheroid. The mean sea level equipotential surface describing the shape of the earth is known as the geoid.

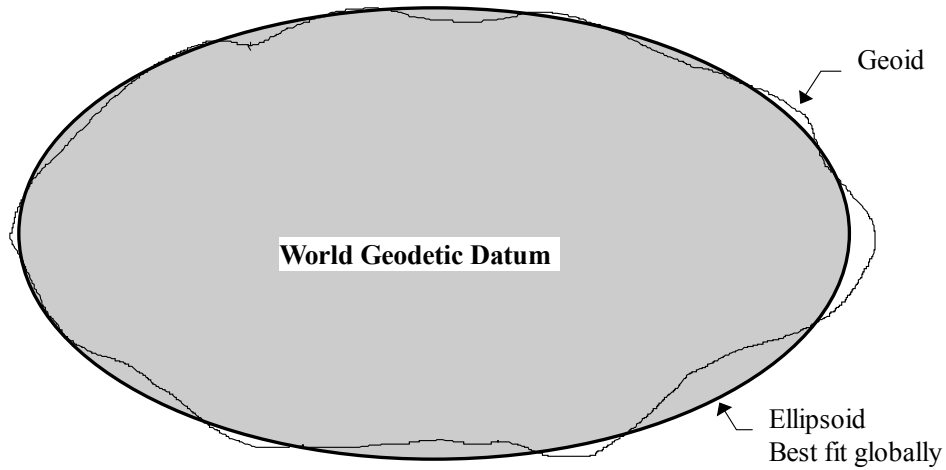

Calculated positions from the GPS are in the World Geodetic System 1984 (WGS84). The WGS84 datum is a global geocentric reference datum that has as its origin at the Earth's centre of mass.

This geocentric datum comprises a spheroid (also known as an ellipsoid) oriented and located in such a manner as to "best-fit" the geoid over the entire earth.

The WGS84 datum is defined by a semi-major axis (a) and flattening (f) of the selected ellipsoid.

a	=	6378137 m
f	=	1/298.2572

## Appendix L-1

### Corrections to Differential GPS Navigation Data

(a) Position calculation delay correction

A correction due to the finite time taken for the GPS system to calculate a position and transfer the information to the acquisition system. A delay of 0.6 s has been determined for calculations using up to eight satellites by flying clover leaf patterns over a reference point. This value is considered to be representative and was used for all delay corrections.

(b) Fiducial synchronisation correction

A correction due to the time lag between when a GPS position is available to the acquisition system and when the next fiducial is available to pair the position with.

(c) "Ranger" corrections

Using the range data which are recorded internally on the aircraft and base GPS receivers every 5 s, "Ranger" calculates the correct positions at 1 s intervals along the flight path. These corrected positions are utilised to correct the raw aircraft position data recorded every second.

Discontinuities (steps) and spikes sometimes occur in the raw aircraft GPS data. These may also be manifested as steps in the correction set.

When such steps in the raw aircraft GPS data occur between successive correction values, the corrections are linearly interpolated to the step boundary using corrections from the appropriate side of the step.

If multiple steps in the raw GPS data occur between successive correction values it is impossible to interpolate corrections over this interval, in which case the intervening GPS data are set to undefined.

(d) Low Pass filter

The problem described in (c) can lead to small steps in the data where the original steps were too small to detect so were not corrected. A low pass 11 point Fuller filter with a cut-off wavelength of 300 m was passed over the navigation data. The terrain data are not filtered.

(e) Infilling "Ranger" data

Data gaps can appear in the "Ranger" data and not in the raw aircraft data. To infill these gaps the difference between the raw aircraft data and the "Ranger" data are calculated at each point for which both exist. It is these differences that are actually infilled, therefore preserving the shape of the aircraft's flight path over the gap in the "Ranger" data whilst still moving the navigation data to the absolute locations defined by the "Ranger" data. The maximum gap that will be infilled by this method is 10 s (700 m).

(f) Reference navigation data to position of magnetometer sensor

The calculated GPS positions refer to the position of the GPS receiver's antenna. Since the magnetometer is the most position-sensitive instrument, all position data are shifted 11.4 m towards the rear of the aircraft to correspond with the position of the magnetometer sensor. In the processing of the gamma-ray and digital elevation model data parallax corrections are made to account for this shift.

(g) Generation of terrain data

The terrain data is generated by subtracting radar altimeter clearance data from the "Ranger" ellipsoidal height data. The terrain data are linearly interpolated to match the 5 s sampling interval of the "Ranger" corrected navigation data.

## **Appendix L-2**

(h) Doppler infill of gaps

Whenever gaps (<5 km) in the GPS data occurred they were infilled with data generated from the doppler navigation system. Gaps in the GPS data greater than 5 km were reflowed.

(i) Barometric infill of height data gaps

Whenever gaps less than 5 km in the GPS height data occur, these gaps are infilled with height data calculated using the recorded barometric and temperature data. Gaps greater than 5 km require the line to be reflowed or an infill line flown.

**Appendix M-1**  
**Geophysical Maps**

Name	Type	Interval or Scale	Reference Number
------	------	-------------------	------------------

1:100 000 scale

Corona	TMI Contours	5 nT	22-2/H54-15/1-1
	Total Count Contours	100 cps	22-2/H54-15/2-1
	Flight line System		22-2/H54-15/3-1
	DEM Contours	5 m	22-2/H54-15/19-1
Fowlers Gap	TMI Contours	10 nT	22-2/H54-15/1-2
	Total Count Contours	100 cps	22-2/H54-15/2-2
	Flight line System		22-2/H54-15/3-2
	DEM Contours	5 m	22-2/H54-15/19-2

1:50 000 scale

Corona One	TMI Contours	2 nT	22-3/H54-15/1-1/1
	Total Count Contours	50 cps	22-3/H54-15/2-1/1
Corona Two	TMI Contours	5 nT	22-3/H54-15/1-1/2
	Total Count Contours	50 cps	22-3/H54-15/2-1/2
Corona Three	TMI Contours	5 nT	22-3/H54-15/1-1/3
	Total Count Contours	25 cps	22-3/H54-15/2-1/3
Corona Four	TMI Contours	1 nT	22-3/H54-15/1-1/4
	Total Count Contours	25 cps	22-3/H54-15/2-1/4
Fowlers Gap One	TMI Contours	2 nT	22-3/H54-15/1-2/1
	Total Count Contours	50 cps	22-3/H54-15/2-2/1
Fowlers Gap Two	TMI Contours	5 nT	22-3/H54-15/1-2/2
	Total Count Contours	50 cps	22-3/H54-15/2-2/2
Fowlers Gap Three	TMI Contours	5 nT	22-3/H54-15/1-2/3
	Total Count Contours	75 cps	22-3/H54-15/2-2/3
Fowlers Gap Four	TMI Contours	5 nT	22-3/H54-15/1-2/4
	Total Count Contours	50 cps	22-3/H54-15/2-2/4

## Appendix M-2

Name	Type	Interval or Scale	Reference Number
<u>1:25 000 scale</u>			
Corona Four North	TMI Contours	1 nT	22-4/H54-15/1-1/4-N
	Total Count Contours	25 cps	22-4/H54-15/2-1/4-N
	Flight line System		22-4/H54-15/3-1/4-N
	TMI Profiles	NA (AGC)	22-4/H54-15/4-1/4-N
Corona One North	TMI Contours	2 nT	22-4/H54-15/1-1/1-N
	Total Count Contours	20 cps	22-4/H54-15/2-1/1-N
	Flight line System		22-4/H54-15/3-1/1-N
	TMI Profiles	NA (AGC)	22-4/H54-15/4-1/1-N
Corona Four South	TMI Contours	1 nT	22-4/H54-15/1-1/4-S
	Total Count Contours	25 cps	22-4/H54-15/2-1/4-S
	Flight line System		22-4/H54-15/3-1/4-S
	TMI Profiles	NA (AGC)	22-4/H54-15/4-1/4-S
Corona One South	TMI Contours	2 nT	22-4/H54-15/1-1/1-S
	Total Count Contours	50 cps	22-4/H54-15/2-1/1-S
	Flight line System		22-4/H54-15/3-1/1-S
	TMI Profiles	NA (AGC)	22-4/H54-15/4-1/1-S
Corona Three North	TMI Contours	2 nT	22-4/H54-15/1-1/3-N
	Total Count Contours	25 cps	22-4/H54-15/2-1/3-N
	Flight line System		22-4/H54-15/3-1/3-N
	TMI Profiles	20 nT/cm	22-4/H54-15/4-1/3-N
Kantappa Creek	TMI Contours	5 nT	22-4/H54-15/1-1/2-N
	Total Count Contours	50 cps	22-4/H54-15/2-1/2-N
	Flight line System		22-4/H54-15/3-1/2-N
	TMI Profiles	50 nT/cm	22-4/H54-15/4-1/2-N
Corona Three South	TMI Contours	2 nT	22-4/H54-15/1-1/3-S
	Total Count Contours	25 cps	22-4/H54-15/2-1/3-S
	Flight line System		22-4/H54-15/3-1/3-S
	TMI Profiles	20 nT/cm	22-4/H54-15/4-1/3-S
Campbells Creek	TMI Contours	5 nT	22-4/H54-15/1-1/2-S
	Total Count Contours	50 cps	22-4/H54-15/2-1/2-S
	Flight line System		22-4/H54-15/3-1/2-S
	TMI Profiles	100 nT/cm	22-4/H54-15/4-1/2-S

### Appendix M-3

Name	Type	Interval or Scale	Reference Number
<u>1:25 000 scale</u>			
Fowlers Gap Four North	TMI Contours	2 nT	22-4/H54-15/1-2/4-N
	Total Count Contours	50 cps	22-4/H54-15/2-2/4-N
	Flight line System		22-4/H54-15/3-2/4-N
	TMI Profiles	NA (AGC)	22-4/H54-15/4-2/4-N
Fowlers Gap One North	TMI Contours	No Map	22-4/H54-15/1-2/1-N
	Total Count Contours	No Map	22-4/H54-15/2-2/1-N
	Flight line System	No Map	22-4/H54-15/3-2/1-N
	TMI Profiles	No Map	22-4/H54-15/4-2/1-N
Fowlers Gap Four South	TMI Contours	2 nT	22-4/H54-15/1-2/4-S
	Total Count Contours	50 cps	22-4/H54-15/2-2/4-S
	Flight line System		22-4/H54-15/3-2/4-S
	TMI Profiles	NA (AGC)	22-4/H54-15/4-2/4-S
Fowlers Gap One South	TMI Contours	2 nT	22-4/H54-15/1-2/1-S
	Total Count Contours	25 cps	22-4/H54-15/2-2/1-S
	Flight line System		22-4/H54-15/3-2/1-S
	TMI Profiles	NA (AGC)	22-4/H54-15/4-2/1-S
Corona	TMI Contours	5 nT	22-4/H54-15/1-2/3-N
	Total Count Contours	50 cps	22-4/H54-15/2-2/3-N
	Flight line System		22-4/H54-15/3-2/3-N
	TMI Profiles	100 nT/cm	22-4/H54-15/4-2/3-N
Fowlers Gap Two North	TMI Contours	5 nT	22-4/H54-15/1-2/2-N
	Total Count Contours	25 cps	22-4/H54-15/2-2/2-N
	Flight line System		22-4/H54-15/3-2/2-N
	TMI Profiles	50 nT/cm	22-4/H54-15/4-2/2-N
Euriowie	TMI Contours	5 nT	22-4/H54-15/1-2/3-S
	Total Count Contours	50 cps	22-4/H54-15/2-2/3-S
	Flight line System		22-4/H54-15/3-2/3-S
	TMI Profiles	100 nT/cm	22-4/H54-15/4-2/3-S
Fowlers Gap Two South	TMI Contours	5 nT	22-4/H54-15/1-2/2-S
	Total Count Contours	25 cps	22-4/H54-15/2-2/2-S
	Flight line System		22-4/H54-15/3-2/2-S
	TMI Profiles	50 nT/cm	22-4/H54-15/4-2/2-S

## Appendix N-1

### AGSO Archive Data, Grid and Magnetic Tape Format for Airborne Geophysical Data

#### CONTENTS

<b>1. THE AGSO SEQUENTIAL FILE STRUCTURE .....</b>	<b>2</b>
(i) Introduction .....	2
(ii) General File Structure .....	2
(iii) Channels and Samples.....	2
(iv) Segment Directory Record (SDR).....	2
(v) Data Record (DAR).....	3
(vi) No Data Value .....	3
(vii) Standard Data Channels .....	3
<b>2. PHYSICAL FORMAT OF STORAGE MEDIA.....</b>	<b>7</b>
(i) General .....	7
(ii) Physical Parameters of Media .....	7
(iii) Tape Structure .....	7
(iv) Physical Records and Blocks .....	7
<b>3. GRID FILE FORMAT.....</b>	<b>7</b>
(i) Header Record.....	7
(ii) Data Records .....	7

#### TABLES

## Appendix N-2

### 1. THE AGSO SEQUENTIAL FILE STRUCTURE

#### (i) Introduction

This appendix describes the general sequential file structure used by AGSO to store airborne geophysical data. For the purpose of this survey ten data chains are involved for each line and tie. They are:

- channel 4 edition 1 (corrected GPS navigation data)
- channel 4 edition 2 (corrected magnetic data)
- channel 4 edition 3 (corrected spectrometric data)
- channel 4 edition 4 (corrected digital elevation model data)
- channel 5 edition 1 (doppler navigation data)
- channel 6 edition 1 (raw spectrometric window data)
- channel 8 edition 1 (raw magnetic data)
- channel 10 edition 1 (raw multi-channel spectrometric data - 100 s )
- channel 14 edition 1 (pressure, temperature, cosmic data)
- channel 16 edition 1 (raw GPS navigation data)

#### (ii) General File Structure

The information pertaining to each traverse (line or tie) is held on the file as a separate entity called a segment. Segments are separated from each other by industry standard EOF records. The end of the file is indicated by two or more consecutive EOF records. Each segment consists of two types of records. Both types are 5120 characters long.

Segment Directory Record (SDR):	the first record on each segment; defines the data content of the segment.
Data Records (DAR's):	hold the measured data values.

#### (iii) Channels and Samples

Data are recorded at regular intervals in time along a traverse. The data recorded at one instant of time are held as any ordered set or sub-set. Each set is held logically distinct and referred to as a channel. The data records in a segment hold all the information for one channel in the form of a data chain, then all the data for the next channel and so on for as many channels as the segment holds.

Each channel is uniquely defined by a channel number and an edition number. The measurement(s) taken for a channel at a given time is called a sample. Samples are held within each channel in increasing order of fiducial (time).

In defining channels the channel number can be used to define the sample format and the edition type of the data. For example, within AGSO, samples with format (longitude, latitude, value, value....) have a channel number of 4 with edition 2 for magnetic data and edition 3 for gamma-ray spectrometric data.

#### (iv) Segment Directory Record (SDR)

Lines and ties are uniquely identified as follows:

Project number:	a unique number to identify the survey
Group number:	a unique number within a survey for each flight made. That is, several

### Appendix N-3

lines may be recorded on one flight (group). AGSO convention is for group numbers to lie between 001 and 999 inclusive.

Segment numbers: a unique number within a survey for a line or tie. AGSO convention is for ordinary line numbers to lie between 1000 and 9999 inclusive and tie line numbers between 100 and 999 inclusive.

The segment directory record identifies the data segment at Project, Group and Segment level and defines the data channels, their structure and the location of their data chains in the segment. Each SDR consists of one or more 10 word blocks. The first, the Segment Identification Block (SIB), identifies the segment and gives the number of data channels held in the segment.

For this survey the number of data channels is nine as mentioned in the introduction. Subsequent blocks, one for each data channel, define the data channels and their location within the segment. These are called Channel Identification Blocks (CIB's). A typical SDR is shown in Figure 1 and its exact format given in Table 1. All unused words in the SDR are set to zero.

The last word in the record in the past has been used as check sum and represents the sum of all the other words in the record. The check sum word is no longer used and is set to zero.

The overall record format is 2I9, 509I10, I12.

#### (v) **Data Record (DAR)**

These each contain 512 values. The first two are fiducials giving the fiducial range of the samples contained in the record. The next 508 represent data values, the second last is always zero (to maintain compatibility with our random access file format) and the last is a record check sum representing the sum of all other values in the record.

If a record is the last one in a data chain for a given channel all unused values are set to zero, with the next channel commencing at the start of the next data record. The N data records in a segment are numbered from 2 to N+1, the SDR being regarded as record one in a segment, with records for a given channel following each other sequentially. The data record addresses in the channel identification block of the SDR refer to this sequential numbering of the data records. A typical segment is shown in Figure 1 and the exact format of a data record given in Table 2.

The overall format of each data record is: 2I9, 509I10, I12.

#### (vi) **No Data Value**

For a variety of reasons it is sometimes necessary to flag a data value to indicate it is to be ignored. This is achieved by replacing the data word in question by the value 536870912. If a gap exists in a data chain each word of every sample involved must be replaced by 536870912, the so-called missing value. Thus a 1:1 correspondence is maintained between the fiducials encompassed by a data chain and its samples.

#### (vii) **Standard Data Channels**

The standard AGSO data channels are:

channel 4 edition 1 (corrected GPS navigation data)

## Appendix N-4

channel 4 edition 2 (corrected magnetic data)  
channel 4 edition 3 (corrected spectrometric data)  
channel 4 edition 4 (corrected digital elevation model data)  
channel 5 edition 1 (doppler navigation data)  
channel 6 edition 1 (raw spectrometric window data)  
channel 8 edition 1 (raw magnetic data)  
channel 10 edition 1 (raw multi-channel spectrometric data - 100 s)  
channel 14 edition 1 (pressure, temperature, cosmic data)  
channel 16 edition 1 (raw GPS navigation data)

### **C4 E1 - Corrected GPS Navigation Data**

channel number = 4  
edition number = 1  
sample size = 2 words  
word 1 = longitude (degrees) \* 1 000 000  
word 2 = latitude (degrees) \* 1 000 000

### **C4 E2 - Corrected Total Magnetic Intensity Data**

channel number = 4  
edition number = 2  
sample size = 4 words  
word 1 and word 2 as for C4 E1  
word 3 = final non micro-levelled TMI (nT) \* 1000  
word 4 = final micro-levelled TMI (nT) \* 1000

### **C4 E3 - Corrected Gamma-ray Spectrometer Data**

channel number = 4  
edition number = 3  
sample size = 7 words  
word 1 = parallax corrected longitude (degrees) \* 1 000 000  
word 2 = parallax corrected latitude (degrees) \* 1 000 000  
word 3 = final total count (counts/sec) \* 1000  
word 4 = final potassium (counts/sec) \* 1000  
word 5 = final uranium (counts/sec) \* 1000  
word 6 = final thorium (counts/sec) \* 1000  
word 7 = radar altimeter (m above ground level)



## Appendix N-6

### C14 E1 - Pressure, Temperature and Cosmic Data

Channel number = 14  
Edition number = 1  
Sample size = 7 words  
word 1 = pressure in (millibars) \* 10  
word 2 = temperature in (degrees Celsius) \* 10  
word 3 - 6 = not used  
word 7 = cosmic channel (counts) \* 1000

### C16 E1 - Raw GPS Navigation Data

Channel number = 16  
Edition number = 1  
Sample size = 4 words  
word 1 = longitude (degrees) \* 1 000 000  
word 2 = latitude (degrees) \* 1 000 000  
word 3 = GPS time (seconds) \* 1000.  
GPS time is recorded in seconds from midnight the previous Sunday  
word 4 = Lag time. Time difference between time when a position is calculated and time until the next fiducial is generated by the data acquisition system. (hundredths of a second)

## Appendix N-7

### 2. PHYSICAL FORMAT OF STORAGE MEDIA

#### (i) General

Each exabyte magnetic tape or CD-ROM consists of a sequence of segments, each segment consisting of one or more physical records. Segments are to be separated by one EOF marker. The end of all information on the media must be flagged by two or more consecutive EOF markers. Industry standard EOF records apply. Records are to be fixed length and each block is to contain one record.

#### (ii) Physical Parameters of Media

- (a) Exabyte Tapes are 8 mm wide, computer grade standard data cartridge.
- (b) CD-ROM are 74 minute (640 Mb) standard media.
- (c) Each media have an external label identifying the airborne survey, character code, recording density, date data written.

#### (iii) Tape Structure

- (a) Written in ASCII.
- (b) No multi-tape files.

#### (iv) Physical Records and Blocks

- (a) Fixed length records of 5120 characters.
- (b) One record per block.

### 3. GRID FILE FORMAT

#### (i) Header Record

The first record on the file defines the content of the grid, including:

- (a) Origin in latitude and longitude.
- (b) Grid cell size.
- (c) Number of rows and columns in the grid.
- (d) Storage mode, i.e. whether the data is stored row by row or column by column. In general the data is stored by row.
- (e) The exact header record format is in Table 3.

#### (ii) Data Records

Each data record contains 320 values in E16.10 format. No location data is held in the data records – the location of a grid point is determined by its sequence within the file. The data for the grid may be sequenced in row or column order (i.e. row by row or column by column respectively). Each row or column is written on consecutive records and begins at the start of a new record. If the rows/columns do not contain a multiple of 320 values the last record for each row/column is padded with zeros. Any point in the grid which is undefined is set to -9999.0.

## **Appendix N-8**

In ROW mode, rows are sequenced from north to south and within each row values are ordered from west to east.

In COLUMN mode, columns are sequenced from west to east and within each column values are ordered from north to south.

## Appendix N-9

Table 1

### Segment Directory Record Format

#### 1. Segment Identification Block

Word	Content And Use	Format
1	Project identification	I9
2	Group identification	I9
3	Segment identification	I10
4	Number of channels on segment	I10
5	Date code – yymmdd	I10
6	Fiducial factor – (fiducial size in seconds)	I10
7	Time of day at fiducial zero in seconds	I10
8	Bearing in degrees (0 – 359) measured east of north	I10
9	Altitude in metres above sea level	I10
10	Ground clearance in m	I10

#### 2. Channel Identification Block (for the Nth channel)

Word	Content And Use	Format
1	Channel code	I10
2	Edition numbers	I10
3	Fiducial interval between samples	I10
4	Number of data values (words) per sample	I10
5	Address of first data record for channel	I10
6	Address of last sample in data chain	I10
7	Fiducial of first sample in data chain	I10
8	Fiducial of last sample in data chain	I10
9	Unused – set to zero	I10
10	Unused – set to zero	I10

## Appendix N-10

**Table 2**

### Data Record Format

<b>Word</b>	<b>Content And Use</b>	<b>Format</b>
1	Fiducial at first data sample in record	I9
2	Fiducial at last data sample in record	I9
3	First word of first sample	I10
4	Second word of first sample	I10
.		
.		
.		
.		
.		
.		
.	First word of second sample	I10
.	Second word of second sample	I10
.		
.		
.	Etc	
511	Always unused – set to zero	I10
512	Always unused – set to zero	I12

- NOTE:
1. A data sample can be of any length greater than zero.
  2. Each record contains an integral number of samples. This may lead to several unused words at the end of the record which are set to zero.
    - i.e. If a sample is 7 words long 72 samples will fit in a data record and words 507–510 will be set to zero.

## Appendix N-11

Table 3

Grid Header Record Format

Character Position	Field Length	Fortran Format	Content
1-60	60	6A10	Grid Identification
61-170	10	11A10	Facts defining data acquisition/processing
171-180	10	A10	x,y units defining grid, Usually degrees.
181-192	12	E12.6	x origin of surface. Bottom left hand corner.
193-204	12	E12.6	y origin of surface. Bottom left hand corner.
205-214	10	A10	Type of z data in grid (e.g. TMI).
215-216	2	A2	Blanks.
217-228	12	I12	Number of data records per column or row.
229-240	12	E12.6	Grid increment in the x direction
241-252	12	E12.6	Grid increment in the y direction
253-262	10	A10	Time when original surface created (hh.mm.ss).
263-286	24	2A10,A4	Filter used on original z data.
287-310	12	2E12.6	x,y co-ordinate of the bottom left hand corner of the grid. Same as x,y origin.
311-320	10	A10	Date of creation of surface (dd/mm/yy).
321-344	24	2A10,A4	Blanks.
345-368	12	2E12.6	x,y co-ordinate of top right hand corner of grid. NOTE: these values are too large by one grid increment for tapes created prior to 01/06/85.
369-373	5	I5	Number of rows in the grid.
374-378	5	I5	Number of columns in the grid.
379-382	4	A4	Blanks.
383-388	6	A6	Defines if the grid is stored in column mode (COLUMN) or row mode (ROW).
389-5120			Blank filled.