

**HANN RIVER – MOUNT MULGRAVE, QLD
AIRBORNE GEOPHYSICAL SURVEY, 1991
OPERATIONS REPORT**

by

M. Bacchin

**Australian Geological Survey Organisation
Record 1997/11**

DEPARTMENT OF PRIMARY INDUSTRIES AND ENERGY

Minister for Resources and Energy: Senator The Hon. Warwick Parer
Secretary: Paul Barratt

AUSTRALIAN GEOLOGICAL SURVEY ORGANISATION

Executive Director: Dr Neil Williams

© Commonwealth of Australia

ISSN: 1039 – 0073

ISBN: 0 642 25017 0

This work is copyright. Apart from any fair dealings for the purposes of study, research, criticism or review, as permitted under the Copyright Act, no part may be reproduced by any process without written permission. Copyright is the responsibility of the Executive Director, Australian Geological Survey Organisation. Inquiries should be directed to the **Information Officer, Australian Geological Survey Organisation, GPO Box 378, Canberra City, ACT, 2601.**

AGSO has endeavoured to use techniques and equipment to achieve results and information as accurately as possible. However such equipment and techniques are not necessarily perfect. AGSO has not and does not make any warranty, statement or representation about the accuracy or completeness of any information contained in this document. **USERS SHOULD NOT RELY SOLELY ON THIS INFORMATION WHEN CONSIDERING ISSUES WHICH MAY HAVE COMMERCIAL IMPLICATIONS.**

CONTENTS

SUMMARY

1. SURVEY AREA AND PARAMETERS.....	1
(i) Area Description.....	1
(ii) Survey Parameters	1
2. LOGISTICS.....	1
(i) Operating Base and Dates of Flying.....	1
(ii) Survey Aircraft and Field Crew.....	2
3. SURVEY EQUIPMENT	2
(i) Major Equipment.....	2
(ii) Navigation	3
(iii) Magnetometer.....	4
(iv) Gamma-ray Spectrometer	4
(v) Altimeter.....	4
(vi) Barometer and Thermometer.....	4
(vii) Base Station Magnetometer.....	5
(viii) Aircraft Data Acquisition	5
4. CALIBRATION	5
(i) Compensation for the Magnetic Field of the Aircraft	5
(ii) Gamma-ray Spectrometer Calibration.....	5
5. DATA PROCESSING.....	6
(i) Data Checking and Editing.....	6
(ii) Flight Path Recovery	7
(iii) Magnetic Data Processing	7
(iv) Gamma-ray Spectrometer Data Processing	9
(v) Digital Elevation Model Data Processing.....	12
(vi) Final Products.....	14
6. REFERENCES	16
APPENDICES	

APPENDICES

- A. Survey Area
- B. Specifications of G833 Helium Magnetometer
- C. Specifications of RMS Instruments Automatic Aeromagnetic Digital Compensator
- D. Specifications of Gamma-ray Spectrometer Components
- E. Specifications of G866 Base Station Magnetometer
- F. Aircraft Data Acquisition System
- G. Compensation Results
- H. Gamma-ray Spectrometer Test Line Location
- I. The Australian Geodetic Datum
- J. Corrections to Differential GPS Navigation Data
- K. Location of sub-areas with extra micro-levelling applied
- L. Geophysical Maps
- M. AGSO Archive Data, Grid and Magnetic Tape Format for Airborne Geophysical Data

SUMMARY

The Australian Geological Survey Organisation (AGSO) flew an airborne geophysical survey of 68181 line km covering the Hann River 1:250 000 map Sheet area with an extension east onto the Cooktown 1:250 000 Sheet area, and the 1:100 000 Sheet area of Mount Mulgrave with an extension east onto the Maytown 1:100 000 Sheet area.

This survey, which formed part of the National Geoscience Mapping Accord, was flown along east – west flight lines 400 metres apart at an altitude of 100 metres above ground level. The survey was flown in the period of June to October 1991.

The total magnetic intensity, gamma-ray spectrometric and digital elevation model data collected during the survey, have been processed and are available for purchase. These data are sold as digital point located data, grids and hardcopy maps, by the Australian Geological Survey Organisation. Colour and greyscale pixel image maps are also available.

1. SURVEY AREA AND PARAMETERS

(i) Area Description

The Hann River – Mount Mulgrave airborne survey covered the entire 1:250 000 topographic map Sheet area of Hann River extending east onto the adjoining 1:250 000 Sheet area of Cooktown to longitude 144° 06' E between latitudes 15° 00' S and 16° 00' S, and the entire 1:100 000 Sheet area of Mount Mulgrave. The survey on Mount Mulgrave extended east onto the Maytown 1:100 000 Sheet area to longitude 144° 10' E between latitudes 16° 00' S and 16° 30' S and west onto the Highbury 1:100 000 Sheet area to longitude 143° 25' E between latitudes 16° 00' S and 16° 05' S. The Mount Mulgrave Sheet area is the north eastern 1:100 000 sheet of the Walsh 1:250 000 Sheet area adjoining Hann River to the south. The exact survey areas are shown in Appendix A.

(ii) Survey Parameters

Altitude:	100 m nominal terrain clearance
Flight line direction:	East – West
Tie line direction:	North – South
Survey line spacing	
Flight line spacing:	400 metres
Tie line spacing:	4000 metres
Survey distance flown	
Lines:	61810 km
Ties:	6371 km
Total distance:	68181 km
Sampling interval	
Magnetics:	0.1 seconds (approx 7 metres)
Gamma–ray spectrometrics:	1.0 seconds (approx 70 metres)
GPS:	1.0 seconds (approx 70 metres)
Doppler:	1.0 seconds (approx 70 metres)
Altimeter:	1.0 seconds (approx 70 metres)
Barometric pressure:	10.0 seconds (approx 700 metres)
Temperature:	10.0 seconds (approx 700 metres)
Accumulated 256 channel spectra:	100.0 seconds (approx 7000 metres)

2. LOGISTICS

(i) Operating Base and Dates of Flying

(a) Operating Base

Aircraft and crew were based at Cooktown in Queensland for the duration of the survey from 12 June to 31 October 1991.

(b) Flying Dates

Calibration flights for the Automatic Aeromagnetic Digital Compensator (used to compensate for the magnetic field of the aircraft) were flown at the start of the survey, after aircraft services and modifications and as required after the magnetometer system was altered.

Production flying commenced on 21 June and continued through to 31 October. The survey required a longer time for completion than expected as a considerable loss in

production flying occurred through geophysical equipment problems, in particular the magnetometer and through very high magnetic diurnal activity restricting the days on which survey flying could be undertaken.

(ii) Survey Aircraft and Field Crew

(a) Aircraft

Aero Commander 500 S "Shrike", VH-BGE

(b) Field Crew

Party Leaders:	Mario Bacchin	14 June to 17 September
	Ross Franklin	17 September to 31 October
Manager:	Ken Horsfall	17 June to 8 July
Technicians:	Phillip Doolan	12 June to 8 August
	Trevor Dalziell	8 August to 31 October
Operators:	Selwyn Wilcox	12 June to 8 August
		30 September to 31 October
	Lars Rickardsson	12 June to 31 October
Pilots (Skywest Aviation):	Capt. Howard Quick	14 June to 8 August
		16 August to 31 October
	Capt. Robert Courtenay	14 June to 31 October

3. SURVEY EQUIPMENT

(i) Major Equipment

Magnetometer:	Geometrics G833 helium magnetometer
Compensator:	RMS Instruments Automatic Aeromagnetic Digital Compensator
Gamma-ray spectrometer:	Geometrics gamma-ray spectrometer consisting of GR900 interface, two DET1024 spectrometer crystal detectors (33.56 l total) and Norland IT-5410 Analog-To-Digital converter
Altimeter:	Collins ALT-50 radar altimeter
Barometer:	AGSO digital – Setra sensor
Thermometer:	AGSO digital – RS sensor
Navigation:	Ashtech XII "Ranger" GPS receivers and Ashtech "Ranger" differential processing software
Doppler:	Racal (Decca) doppler antenna (80561 CAD) Sperry C 14 D compass
Video:	National colour video camera (WV CL 302E) National VCR (NV 180) National LCD TV (TCL 3A)

National Time Date Generator (WJ 810)

Acquisition hardware: HP-A400 computer, HP9122 720 Kb 3.5 inch dual floppy disc drive and HP Thinkjet printer

Acquisition software: AGSO-developed HP assembler language program

(ii) Navigation

(a) GPS Navigation System

Aircraft navigation was carried out using an Ashtech XII global positioning system (GPS) receiver. The receiver in the aircraft received range data from satellites every second and calculated the current latitude and longitude coordinates in the World Geodetic System 1984 (WGS84) of the aircraft. The range data were recorded internally in the GPS receiver every ten seconds.

The calculated position of the aircraft was recorded on the aircraft acquisition system every second and was used to provide the pilot with aircraft guidance information on an LCD display.

To enable differential GPS post flight processing, a second GPS receiver was set up in AGSO's field office caravan as a GPS base station and internally recorded range data every ten seconds. The data were post processed using Ashtech 'Ranger' software at the end of each flying day. The error in position of the post processed flight path data is approximately 5-10 metres.

The position of the base station GPS receiver was accurately determined by differential GPS surveying using as a fixed reference point the Marton trig station QGS 1275 (PM 92347) located near the Cooktown airport.

The coordinates in WGS 84 for the reference point are:

Longitude	:145° 10' 37.1557" E
Latitude	: 15° 27' 01.9051" S
Ellipsoidal height	:123.792 metres

The determined base station GPS coordinates (WGS 84) were:

Longitude	:145° 11' 07.820713" E
Latitude	: 15° 26' 52.535257" S
Ellipsoidal height	:129.6757 m (this height used until 2 September)
	:133.7557 m (this height used from 2 September after antenna raised by 4.08 metres)

(b) Doppler Navigation System

Doppler navigation data were used as a secondary navigation system on the aircraft and as a back-up for the main navigation system (GPS), infilling gaps less than 10 km in the GPS data.

(c) Video Flight Path Recording

The aircraft's flight path was recorded on a VHS video system consisting of a National colour video camera with a wide angle lens, a National VCR and a National LCD TV. This

system was also used for locating start and end fiducial values on the gamma-ray spectrometer test lines.

(iii) Magnetometer

A Geometrics G833 helium magnetometer, with the sensor mounted in a boom attached to the rear of the aircraft, was used for the survey. The specifications of the magnetometer are summarised in Appendix B.

The recorded total magnetic field data were compensated in real time using an RMS Instruments automatic aeromagnetic digital compensator (AADC). The AADC compensates for the effects of aircraft motion and heading. The specifications of the AADC are summarised in Appendix C. Compensation procedures are described in Chapter 4.

The AADC applies a low pass filter to the total magnetic field intensity data using a second order 0.9 Hz recursive Butterworth filter. The filtered compensated total magnetic field intensity data were recorded on the aircraft acquisition system.

(iv) Gamma-ray Spectrometer

A Geometrics gamma-ray spectrometer, incorporating two DET1024 crystal detectors with a total volume of 33.56 litres, was used. The crystal gains and temperatures were controlled by a Geometrics GR900 Detector Interface console. Analog to digital conversion was achieved through a Norland IT-5410 Analog-To-Digital converter. Appendix D summarises the specifications of the gamma-ray spectrometer components.

Five channels of data were recorded once a second using the following window limits:

total count	0.40-3.00 MeV
potassium	1.35-1.57 MeV
uranium	1.63-1.89 MeV
thorium	2.42-2.82 MeV
cosmic	3.00-6.00 MeV

A cumulative 256 channel spectrum between 0.0 MeV and 3.0 MeV was recorded every 100 seconds. Total system dead-time was reduced by electronically suppressing counts in the 0.0 MeV - 0.3 MeV energy range before these signals reached the analogue to digital converter. This reduced the system dead-time to 13.95 microseconds/pulse. Gamma-rays in the 0.0 MeV – 0.3 MeV energy range are not very diagnostic in airborne geophysical surveying.

(v) Altimeter

A Collins ALT-50 radar altimeter was used to measure ground clearance. The radar altimeter display indicates ground clearance from 0-2000 feet. The manufacturer's specifications claim a +/-2% accuracy for the ALT-50 system.

(vi) Barometer and Thermometer

Atmospheric temperature and pressure were measured using a digital barometer (Setra sensor) and digital thermometer (RS sensor). Although both of these units were built by the AGSO, the sensors were factory calibrated and no AGSO calibrations were performed.

(vii) Base Station Magnetometer

Daily variations of the Earth's magnetic field were monitored using a Geometrics G866 proton precession base station magnetometer, the specifications of which are given in Appendix E. The base station was set up in an area of shallow magnetic gradient, on an AGSO "first order repeat magnetic site", away from cultural influences and within telemetry range of AGSO's office caravan. Data from the base station were telemetered back to the AGSO's field office caravan for display and recording on an Amstrad PC512 lap-top computer. The telemetry system used AGSO-built modems incorporating Phillips 828 UHF mobile radiotelephone transmit boards at a frequency of 471.8 MHz.

Throughout the survey, base station data were recorded every twenty seconds during production flights.

(viii) Aircraft Data Acquisition

The aircraft acquisition program and system were run using a HP-A400 computer with data recorded on 3.5 inch floppy discs using a HP9122 720 Kb disc drive.

The acquisition program was developed in-house at AGSO. The data are displayed in real time in the aircraft in analogue form on a HP Thinkjet printer. A schematic diagram of the aircraft's acquisition system is shown in Appendix F.

4. CALIBRATION

(i) Compensation for the Magnetic Field of the Aircraft

Compensation flights were flown prior to the start of the survey and after aircraft services and modifications either to the aircraft or to the Helium magnetometer system. These flights were conducted over magnetically quiet zones 50 km offshore east of Cooktown at an altitude of 1800 metres above sea level.

The compensation comprises a series of rolls($\pm 10^\circ$), pitches($\pm 5^\circ$) and yaws($\pm 5^\circ$) in the four cardinal headings to enable the AADC to calculate correction coefficients needed to remove aircraft manoeuvre noise. Each manoeuvre component was of 20 seconds duration.

The compensation manoeuvres were repeated after calculation of the coefficients to check the compensation quality. Peak-to-peak noise during repeat manoeuvres and after the final compensation was 0.30 nT or less. On normal survey flights, noise levels from all sources were generally less than 0.20 nT peak-to-peak.

The AADC calculates basic statistics which reflect the degree of merit of the compensation. These include the standard deviation of the recorded data without corrections applied, the standard deviation with the corrections applied, the improvement ratio (the ratio of the standard deviation of the recorded data without and with the corrections applied) and the vector norm (the degree of difficulty in calculating the corrections). Examples of these statistics are given for some of the compensations in Appendix G.

(ii) Gamma-ray Spectrometer Calibration

Crystal alignment checks were performed (using a small thorium source) on 16 June, 10 July (no source used), 5 and 16 September, and 17 October 1991. The resolution of the gamma-ray spectrometer system was measured using the full width at half maximum method (IAEA, 1991). Adjustments were made such that the resolution of the thorium (2.62 MeV)

photopeak was 6% or better. Gamma-ray spectrometer channels were positioned such that the thorium photopeak was centred within one channel (± 12 keV) of channel 223.

Gamma-ray spectrometric test lines were flown at the beginning and end of each production flight. These lines were flown at survey altitude along the Peninsula Development road 12 km north-west of Laura with data recorded for 100 seconds or approximately 6.5 km. The location of the test line used for the Hann River – Mount Mulgrave survey is shown in Appendix H.

Although background corrections for gamma-ray spectrometrics are calculated using a full spectrum method (Minty, 1992) at AGSO, Canberra, background estimation lines were flown as a means of data checking. Background lines, of 300 seconds duration, were flown at 915 metres above ground level at the start and end of each flight.

After each flight, statistics were calculated from data recorded between fixed reference points, observed on video, along the test line and for background lines. These statistics were recorded in spreadsheet form and compared with the preceding flights in order to detect any irregularities. In particular, the difference between the average in the total count channel on the first test line and the last test line of each flight was analysed. This value was generally well within 20% variation which would be considered acceptable.

5. DATA PROCESSING

Flight path recovery, data checking and editing, and preliminary gridding and imaging were performed at the survey base. Final magnetic, gamma-ray spectrometric and digital elevation model data processing were carried out in Canberra using the Geophysical Mapping Section's airborne data processing system, ARGUS.

The data processing was divided into the following three tasks:

- (a) Data located on the Hann River 1:250 000 Sheet area were processed as one block.
- (b) Data located on the Mount Mulgrave 1:100 000 Sheet area were processed as one block.
- (c) The gridded data for the Mount Mulgrave block were adjusted via low order polynomial (degree three or less) warping such that they were levelled to the gridded data for the Hann River block. The point-located data for the Mount Mulgrave block were then adjusted via low order polynomial corrections such that they were consistent with the adjusted gridded data for these sheets. Thus the point-located data for both blocks were levelled to each other.

(i) Data Checking and Editing

Data recorded on the aircraft acquisition system were transferred on a flight by flight basis to a hard disk on a Compaq 386 personal computer and edited for missing values, noise, spikes or steps using AGSO-developed software. All the recorded data were displayed for each survey line and any errors were interactively corrected. Anomalies arising from cultural influences, such as sheds, houses and fences, were usually not edited out.

(ii) Flight Path Recovery

Range data which were recorded internally every ten seconds on both GPS receivers were post-processed daily in the field using "Ranger" - an Ashtech proprietary program. "Ranger" calculates the corrected flight path (longitude, latitude and height) relative to the WGS84 reference ellipsoid.

At the end of each flying day the corrected longitude and latitude data calculated at ten second intervals by "Ranger" were used to correct the GPS data recorded every one second on the aircraft acquisition system. As well as the standard "Ranger" corrections, other acquisition system specific corrections were applied. Position data were converted from the WGS84 coordinate system to the Australian Geodetic Datum 1984 (AGD84) coordinate system which is defined in Appendix I. The full correction procedure is described in Appendix J and is outlined below:

- (a) Position calculation delay correction.
- (b) Fiducial synchronisation correction.
- (c) "Ranger" corrections.
- (d) Low pass filter.
- (e) Coordinate system conversion.
- (f) Reference navigation data to position of magnetometer sensor.
- (g) Doppler infill of gaps.

The fully corrected flight path was plotted each day to check the position of survey lines and their spacing. For the survey line spacing of 400 metres, navigation reflies were determined by the following criteria:

Across Track Deviation	Distance along line	GPS Data Gap
200 metres	greater than 5 km	greater than 10 km

Whenever the across track deviation and along line distance or the GPS data gap were exceeded, the survey line was reflight or an infill line flown to rectify the problem. These criteria were exceeded on five survey lines.

(iii) Magnetic Data Processing

Raw magnetic data were merged with the navigation data, and diurnal variation corrections were removed. For the Hann River data the IGRF 1990 geomagnetic reference field, updated to 1991.67 at an altitude of 300 metres above sea level, which was estimated to be the mean survey altitude, was then subtracted from the data. For the Mount Mulgrave data the IGRF updated to 1991.83 at an altitude of 300 metres above sea level was subtracted from the data.

The IGRF was calculated from the coefficients defined by the IAGA (1991). All magnetic values were adjusted by a constant so that the average residual magnetic field value was approximately 5000 nT.

The data were levelled using standard tie line levelling procedures. The steps involved in the tie line levelling were as follows:

Hann River block:

- (a) Tie line 320 was chosen as a reference tie.
- (b) All other ties were levelled to tie line 320 using degree three polynomial adjustments.
- (c) Lines were adjusted on a flight by flight basis using degree three polynomial adjustments to minimise the differences at line/tie crossover points.
- (d) Ties were then adjusted using degree three polynomial adjustments to minimise the crossover differences.
- (e) Finally the lines were again individually adjusted using degree one polynomial adjustments to minimise crossover differences.

The data were micro-levelled using the technique described by Minty (1991). This process of micro-levelling was applied twice to the entire Hann River Sheet area and a third time to three sub-areas within the sheet. See Appendix K for location of these sub-areas. Filter characteristics were different for each application of the micro-levelling and were as follows:

On the first application to the entire Hann River survey area:

- (a) Low pass filter in the flight line direction with a cut-off wavelength of 8000 metres.
- (b) High pass filter in the tie line direction with a cut-off wavelength of 1600 metres.
- (c) Correction strings were low pass filtered with a cut-off wavelength of 1000 metres before being applied to the line data and were constrained to fall within the range +/- 10 nT.

On the second application of micro-levelling only the three sub-areas were adjusted using the following filter characteristics:

- (a) Low pass filter in the flight line direction with a cut-off wavelength of 8000 metres.
- (b) High pass filter in the tie line direction with a cut-off wavelength of 5000 metres.
- (c) Correction strings were low pass filtered with a cut-off wavelength of 1000 metres before being applied to the line data and were constrained to fall within the range +/- 1.5 nT.

On the third application of micro-levelling to the entire Hann River survey area the filter characteristics were as follows:

- (a) Low pass filter in the flight line direction with a cut-off wavelength of 3000 metres.
- (b) High pass filter in the tie line direction with a cut-off wavelength of 1600 metres.

- (c) Correction strings were low pass filtered with a cut-off wavelength of 1000 metres before being applied to the line data and were constrained to fall within the range ± 1.5 nT.

Mount Mulgrave block:

- (a) Tie line 210 was chosen as a reference tie.
- (b) All other ties were levelled to tie line 210 using degree three polynomial adjustments.
- (c) Lines were adjusted on a flight by flight basis using degree three polynomial adjustments to minimise the differences at line/tie crossover points.
- (d) Ties were then adjusted using degree three polynomial adjustments to minimise crossover differences.
- (e) Finally the lines were individually adjusted using degree one polynomial adjustments to minimise crossover differences.

The data were micro-levelled using the technique described by Minty (1991). Filter characteristics used for the Mount Mulgrave block were as follows:

- (a) Low pass filter in the flight line direction with a cut-off wavelength of 8000 metres.
- (b) High pass filter in the tie line direction with a cut-off wavelength of 1600 metres.
- (c) Correction strings were low pass filtered with a cut-off wavelength of 2500 metres before being applied to the line data and constrained to fall in the range ± 10 nT.

The micro-levelled data from both survey areas were gridded as individual grids using an ARGUS gridding program implementation of the minimum curvature technique described by Briggs (1974), with a 3 second (90 metre) grid cell size.

After the levelling and merging of the two survey areas as described in the beginning of this chapter the complete data set was levelled as one grid using the same gridding software and the same grid cell size as the individual grids.

(iv) Gamma-ray Spectrometer Data Processing.

Raw gamma-ray spectrometric and altimeter data were merged with the navigation data to create a located raw gamma-ray spectrometric dataset. Background estimates for each of the four recording windows were removed. These estimates were determined as follows:

- (a) Aircraft and Cosmic Background
Minty and Richardson (1989) derived aircraft and cosmic spectra for the AGSO aircraft from high altitude calibration flights.
- (b) Atmospheric Radon Background
Full spectrum analysis (Minty, 1992) was used to calculate the radon contribution to the background in the uranium window.
- (c) Total Background

The total background in the uranium window is the sum of the aircraft, cosmic and radon background. The total count and potassium window backgrounds were estimated directly from the uranium background since they are linearly dependent (Grasty, 1975). The thorium window was considered to be unaffected by atmospheric radon, so total thorium background was estimated from the aircraft and cosmic backgrounds.

Channel interaction corrections (stripping) to correct for Compton scattering were then applied to the data. Stripping ratios for the AGSO system were determined by Minty and others (1990) using portable calibration sources. The corrections were applied as follows:

$$\begin{aligned} N_{\text{TH(corrected)}} &= N_{\text{TH}} \\ N_{\text{U(corrected)}} &= N_{\text{U}} - A \times N_{\text{TH(corrected)}} \\ N_{\text{K(corrected)}} &= N_{\text{K}} - B \times N_{\text{TH}} - C \times N_{\text{U(corrected)}} \end{aligned}$$

where

$$\begin{aligned} N_{\text{TH}} &= \text{counts in the thorium channel} \\ N_{\text{U}} &= \text{counts in the uranium} \\ N_{\text{K}} &= \text{counts in the potassium channel} \\ A &= 0.506 \\ B &= 0.521 \\ C &= 0.902 \end{aligned}$$

The data were next corrected for height attenuation and reduced to a nominal flying height of 100 metres. Where the aircraft attained a height of 300 metres or higher above the ground gamma-ray spectrometric data have been set to undefined. Height attenuation corrections were made using the following formula:

$$N_{\text{corrected}} = N_{\text{uncorrected}} e^{-u(H-h)}$$

where

$$\begin{aligned} N_{\text{corrected}} &= \text{corrected counts} \\ N_{\text{uncorrected}} &= \text{uncorrected counts} \\ H &= \text{nominal flying height} \\ h &= \text{measured flying height} \\ u &= \text{attenuation coefficient} \end{aligned}$$

Attenuation coefficients for each channel are given below

$$\begin{aligned} u_{\text{total count}} &= 0.00656 \\ u_{\text{potassium}} &= 0.00755 \\ u_{\text{uranium}} &= 0.00557 \\ u_{\text{thorium}} &= 0.00557 \end{aligned}$$

Hann River block:

Total count, potassium, and thorium channels were not levelled using standard tie line levelling procedures but were only micro-levelled using the technique described by Minty (1991). The process of micro-levelling was applied once to the potassium and thorium data. Whereas the total count data were micro-levelled with one set of filter parameters applied to the entire Hann River survey area and a different set of filter parameters applied over two sub-areas within the survey area. The filter parameters applied over the entire Hann River survey area were as follows:

- (a) Low pass filter in the flight line direction with a cut-off wavelength of 20.0 km.
- (b) High pass filter in the tie line direction with a cut-off wavelength of 1600 metres.
- (c) Correction strings were low pass filtered with a cut-off wavelength of 1000 metres for total count data and 250 metres for potassium and thorium data.

The two sub-areas for which the micro-levelling was applied twice had the following filter parameters:

- (a) Low pass filter in the flight line direction with a cut-off wavelength of 5000 metres.
- (b) High pass filter in the tie line direction with a cut-off wavelength of 1600 metres.
- (c) Correction strings were low pass filtered with a cut-off wavelength of 500 metres.

This second application of micro-levelling was applied only to the total count data. See Appendix K for location of the sub-areas.

The uranium channel data were levelled using standard tie line levelling procedures. However prior to sampling the crossover points, a low pass filter with a cut-off wavelength of 1000 metres was applied to the data. These filtered data were only used for the crossover analysis and the final data have not been filtered. The steps involved in tie line levelling were as follows:

- (a) Tie line 320 was chosen as a reference tie.
- (b) All other ties were levelled to tie line 320 using degree three polynomial adjustments.
- (c) Lines were adjusted on a flight by flight basis using degree three polynomial adjustments to minimise the differences at line/tie crossover points.
- (d) Ties were then adjusted using degree three polynomial adjustments to minimise crossover differences.
- (e) Finally the lines were individually adjusted using degree one polynomial adjustments to minimise crossover differences.

The data were micro-levelled using the same technique as the total count, potassium and thorium data. The entire Hann River survey area was micro-levelled with the same set of filter characteristics as those used for the potassium and thorium data. A second set of filter

parameters was applied to a sub–area. See Appendix K for location of this sub–area. The filter characteristics for this second set were as follows:

- (a) Low pass filter in the flight line direction with a cut-off wavelength of 5000 metres.
- (b) High pass filter in the tie line direction with a cut-off wavelength of 1600 metres.
- (c) Correction strings were low pass filtered with a cut-off wavelength of 250 metres.

Mount Mulgrave block:

Total count, potassium, uranium, and thorium channels were not levelled using standard tie line levelling procedures but were only micro–levelled using the technique described by Minty (1991). The process of micro–levelling was applied once to the thorium data. The total count, potassium, and uranium channels were micro–levelled with the same set of filter parameters applied to the entire Mount Mulgrave survey area and a different set over a sub–area. See Appendix K for the sub–area location. The filter parameters applied over the entire Mount Mulgrave survey area to all four channels were as follows:

- (a) Low pass filter in the flight line direction with a cut-off wavelength of 20.0 km.
- (b) High pass filter in the tie line direction with a cut-off wavelength of 1600 metres.
- (c) Correction strings were low pass filtered with a cut-off wavelength of 250 metres.

The sub–area for which the micro–levelling was applied twice had the following filter parameters:

- (a) Low pass filter in the flight line direction with a cut-off wavelength of 5000 metres.
- (b) High pass filter in the tie line direction with a cut-off wavelength of 1600 metres.
- (c) Correction strings were low pass filtered with a cut-off wavelength of 250 metres.

This second application of micro–levelling was applied only to the total count, potassium and uranium channel data.

The four channels of micro–levelled data from both survey areas were gridded as individual grids for each survey area using an ARGUS gridding program implementation of the minimum curvature technique described by Briggs (1974), with a 3 second (90 metre) grid cell size.

After the levelling and merging of the two survey areas as described in the beginning of this chapter the complete data sets were levelled as one survey area for each channel using the same gridding software and the same grid cell size as the individual grids.

(v) Digital Elevation Model Data Processing

The processing of the digital elevation model data was undertaken by Richard Almond as part of the Cape York Peninsula Land Use Strategy program. This description of the processing has been extracted from the report by Hone and Almond (1995).

Hann River block:

Post processing of range data collected by the aircraft and base GPS receivers by "Ranger" - an Ashtech proprietary program supplied by the makers of the GPS receivers used by the AGSO survey of Hann River; generates heights relative to the WGS84 ellipsoid, as well as horizontal locations.

The following acquisition system specific corrections, which are described in Appendix J, were applied to the height data:

- (a) Position calculation delay correction.
- (b) Fiducial synchronisation correction.
- (c) Coordinate system conversion.

The corrected height data, which are relative to the AGD84 reference ellipsoid, were then linearly interpolated to one second samples (70 metres) and merged with the longitude and latitude data.

At this stage, considerable editing of the height data was done to remove spurious data.

A radar altimeter provided the aircraft's ground clearance, the altimeter data being sampled every one second.

The raw ground elevation data were then calculated as the difference between the height of the aircraft above the ellipsoid and the height of the aircraft above the ground. These raw elevation data calculated every one second (70 m along the ground) are relative to the AGD84 reference ellipsoid - the ellipsoid being a horizontal datum.

The next step was to convert the heights relative to the AGD84 ellipsoid to heights relative to the geoid. The geoid, which is defined as "the equipotential surface of the gravity field which best approximates mean sea level", is usually chosen as the datum to which heights plotted on maps are referred. The height of the geoid above the AGD84 ellipsoid is called the geoid-ellipsoid separation or N value.

Geoid-ellipsoid separation information for the Hann River Sheet area were supplied by the Australian Surveying and Land Information Group (AUSLIG). The set of N values were supplied as a 10 minute of arc (approximately 18 km) grid. AUSLIG also provides a program "DINTER" which uses bilinear interpolation to calculate N values on a one minute of arc (approximately 1 800 metre) grid. These values were then regrided. to a cell size of 3 seconds of arc (approximately 80 metres). This grid of N values was then used to calculate correction strings to be subtracted from the elevation data. The correction strings were low pass filtered with a cut-off wavelength of 1 000 metres before being applied to the point-located elevation data.

The elevation data were then corrected to account for the vertical separation between the antenna of the aircraft's GPS receiver, on the roof of the aircraft, and radar altimeter on the belly of the aircraft. This antenna separation distance of 1.675 metres was also subtracted from the elevation data.

The elevation data were levelled using tie line information and then micro-levelled.

The steps involved in the tie line levelling were as follows:

- (a) Tie line 240 was chosen as a reference tie.
- (b) All other ties were levelled to tie line 240 using degree three polynomial adjustments.
- (c) Lines were adjusted to the ties on a flight basis using degree three polynomials.
- (d) Ties were then adjusted to minimise crossover differences using degree one polynomial adjustments.
- (e) Finally the lines were adjusted individually to minimise crossover differences, using degree one polynomial adjustments.

Tie line levelling is of a heuristic nature, and gridding and viewing is conducted during the process to ensure the best parameters are chosen.

In the micro-levelling the process described by Minty (1991) was used with the following filters:

- (a) Low pass filter in the flight line direction with a cut-off wavelength of 4 000 metres.
- (b) High pass filter in the tie line direction with a cut-off wavelength of 3 200 metres.
- (c) Correction strings were low pass filtered with a cut-off wavelength of 1 000 metres before being applied to the position located data.

The accuracy of the position located height data is expected to be better than +/- 10 metres. Relative precision from point to point along a flight line is expected to be better than +/- 5 metres.

The micro-levelled data gridded using Briggs (1974) minimum curvature technique with a 3 second (90 metre) grid cell size.

(vi) Final Products

- (a) Standard AGSO geophysical maps

An AGSO standard set of geophysical maps have been produced at scales of 1:250 000 and 1:100 000 for the Hann River survey area and at 1:100 000 scale for the Mount Mulgrave survey area. Flight path, profiles and contour maps were produced using ARGUS programs. The standard set of maps produced are shown in Appendix L.

- (b) Digital Data

Final processed point-located data and grids were archived in the standard AGSO ARGUS format, on nine track magnetic tape (6250 bpi) in ASCII format (Appendix M).

- (c) Pixel Image Maps

Additional to the standard AGSO geophysical maps listed in Appendix L, pixel image maps have been compiled using the method described by Milligan and others (1992). The following pixel image maps have been released:

- (a) Greyscale 1:250 000 scale image of the first vertical derivative of the total magnetic intensity reduced to the pole with easterly illumination covering the Hann River and Mount Mulgrave survey areas.
- (b) Colour 1:250 000 scale image of total magnetic intensity reduced to the pole with illumination from the east covering the Hann River and Mount Mulgrave survey areas.
- (c) Colour 1:250 000 scale image of gamma-ray potassium, uranium and thorium colour composite covering the Hann River and Mount Mulgrave survey areas.
- (d) Colour 1:250 000 scale image of digital elevation model with northwest illumination covering the Hann River survey area.

6. References

Briggs, I.C., 1974 - Machine contouring using minimum-curvature. *Geophysics*, **39**, 39-48.

Grasty, R. L., 1975 - Uranium measurements by airborne gamma-ray spectrometry. *Geophysics*, **40**, 503-519.

Hone, I. G., Almond, R., 1995 - Airborne Geophysical Data for Cape York Peninsula. *A report for the Natural Resources Analysis Program on Cape York Peninsula Land Use Strategy*.

International Association of Geomagnetism and Aeronomy, 1991 - Division V Working Group 8. International Geomagnetic Reference Field, 1991 Revision. *Journal of Geomagnetism and Geoelectricity*, **43**, 1007-1012.

International Atomic Energy Agency, 1991 - Airborne Gamma Ray Spectrometer Surveying. *International Atomic Energy Agency Technical Reports Series Number 323*, IAEA Vienna.

Milligan, P. R., Morse, M. P., and Rajagopalan, S., 1992 - Pixel map preparation using the HSV colour model. *Exploration Geophysics*, **23**, 219-224.

Minty, B. R. S., Morse, M. P., and Richardson, L. M., 1990 - Portable calibration sources for airborne gamma-ray spectrometers. *Exploration Geophysics*, **21**, 187-195.

Minty, B. R. S., 1991 - Simple micro-levelling for aeromagnetic data. *Exploration Geophysics*, **22**, 591-592.

Minty, B. R. S., 1992 - Airborne gamma-ray spectrometric background estimation using full spectrum analysis. *Geophysics*, **57**, 279-287.

Minty, B. R. S., and Richardson, L. M., 1989 - Calibration of the BMR airborne gamma-ray spectrometer upward-looking detector, February 1989. *Bureau of Mineral Resources, Australia, Record 1989/8*.

APPENDIX A-1-
HANN RIVER

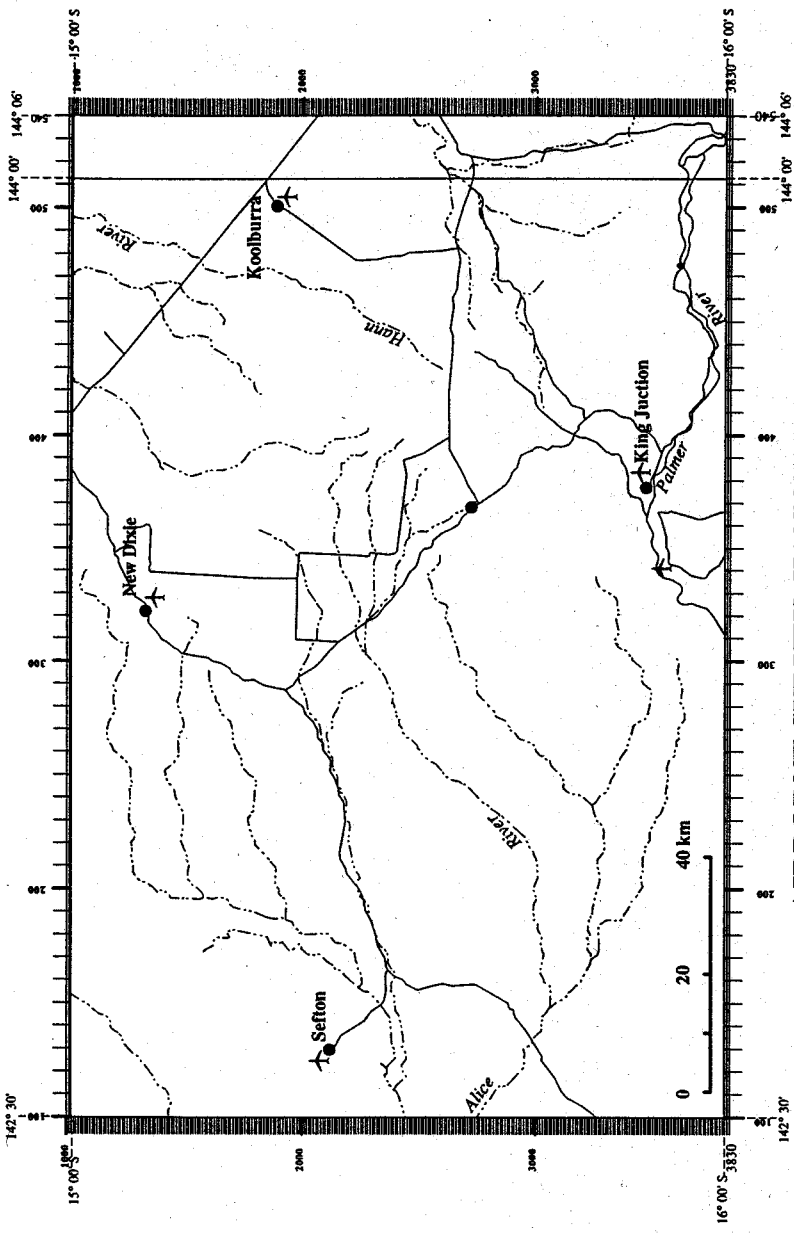

AIRBORNE SURVEY, HANN RIVER, QLD,
1991 P570

INDEX TO 1:250 000 MAP SERIES

HOLROYD	EBAGOOLA	CAPE MELVILLE
RUTLAND PLAINS	HANN RIVER	COOKTOWN
GALLERAITH	WALSH	MOSSMAN

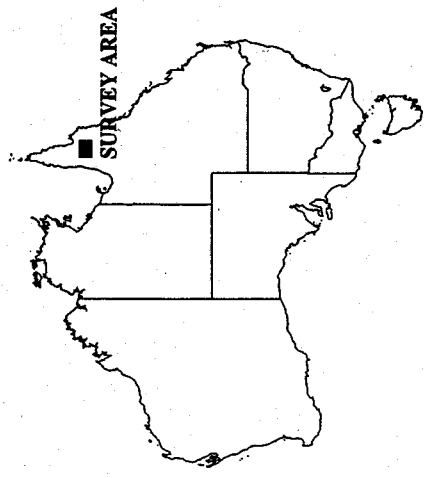

APPENDIX A-2- MOUNT MULGRAVE

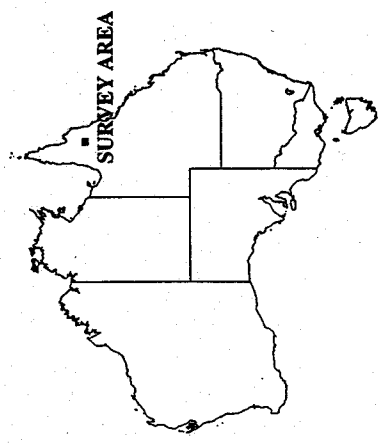
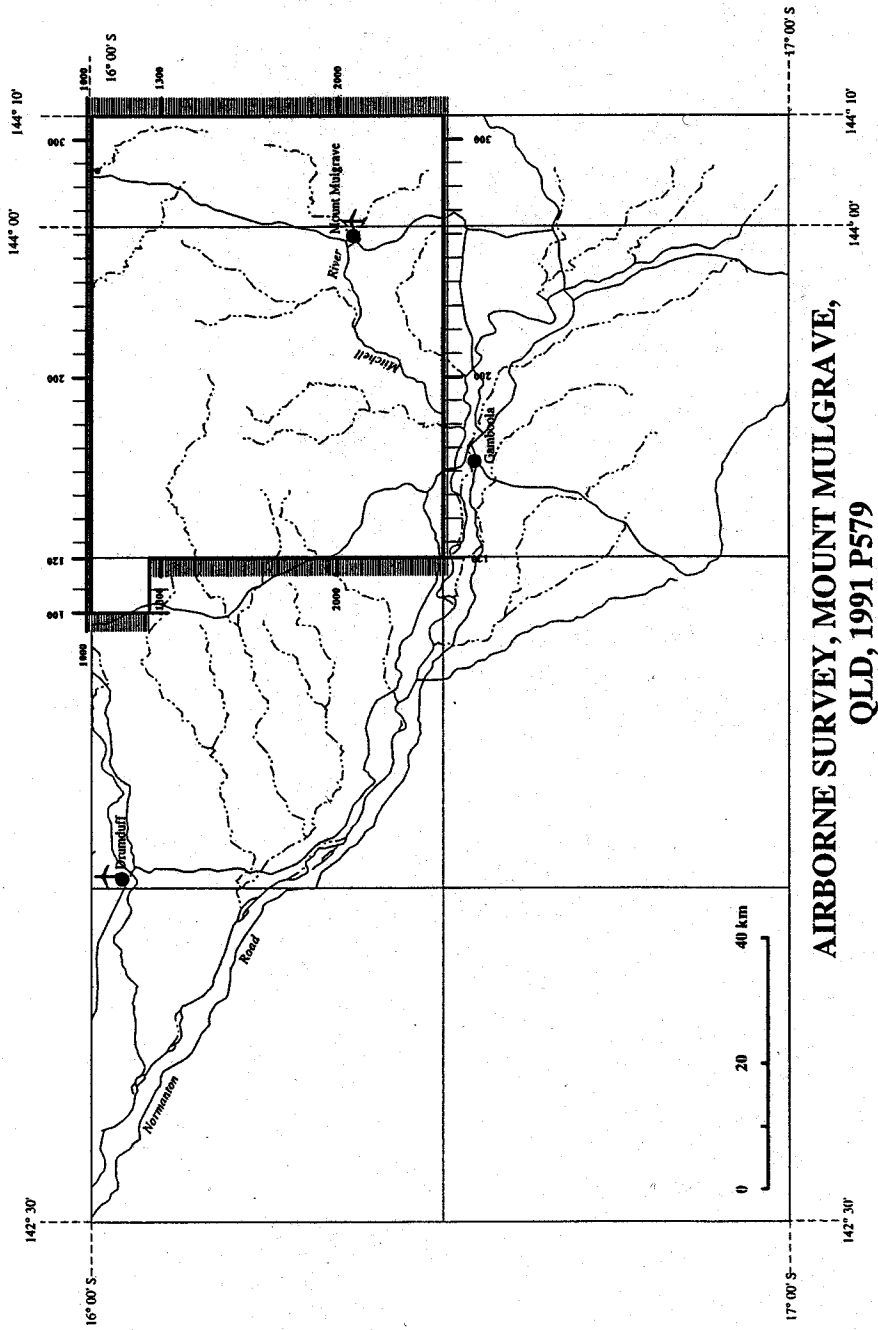

INDEX TO 1:250 000 MAP SERIES

RUTLAND PLAINS	HANN RIVER	COOKTOWN	
GALBRAITH	WALSH	MOSSMAN	
NORMANTON	RED RIVER	ATHERTON	

APPENDIX B

SPECIFICATIONS - G833 HELIUM MAGNETOMETER

Operating Range:	20,000 to 95,000 nT
Temperature:	-20 to +50 C
Sensitivity:	0.0032 nT/root Hz RMS
Bandwidth:	350 Hz (-3dB point)
Loop scan rate:	1000 cycles/second
Input power:	28 V DC, 6 A max.
Output signal:	At He gyromagnetic frequency, approximately 28.02468 Hz/nT. Three volts peak to peak
Dimensions:	Sensor cell - 80 mm diameter x 145 mm length Scan processor - 270 x 120 x 85 mm Control panel - 19 inch rack mount
Weight:	approximately 6 kg.

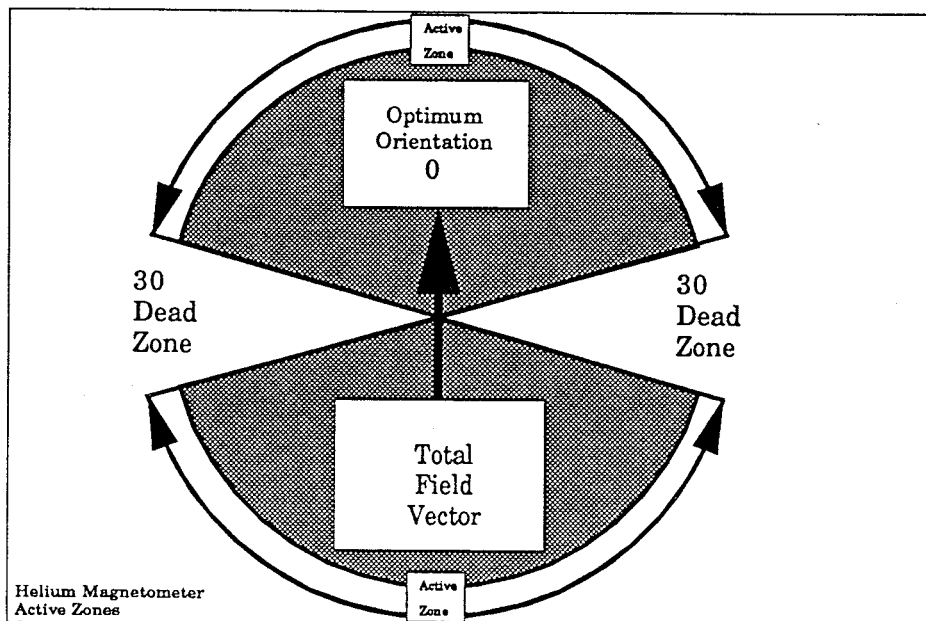

APPENDIX C-1

Specifications – RMS Instruments Automatic Aeromagnetic Digital Compensator

INPUTS:	one or two high sensitivity magnetometers of optical absorption type.
INPUT FREQUENCY RANGE:	70 kHz – 350 kHz – Cs sensor 140 kHz – 700 kHz – K sensor 560 kHz – 2800 kHz – He sensor 850 Hz – 4260 Hz – Overhauser
MAGNETIC FIELD RANGE:	20,000 – 100,000 nT
RESOLUTION:	1 pT (picotesla)
COMPENSATION PROCEDURE:	improvement ratio 10 – 20 (typical for total field) improvement ratio 20 – 100 (typical for gradient)
ACCURACY OF COMPENSATION:	0.035 nT standard deviation for the entire aircraft flight envelope in the bandwidth 0 – 1 Hz typical
DATA OUTPUT RATE:	10 Hz
SYSTEM FREQUENCY RESPONSE:	0 – 0.9 Hz
INTERNAL SYSTEM NOISE:	less than 2 pT (standard deviation in the bandwidth 0 – 1 Hz)
DURATION OF CALIBRATION FLIGHT MANOEUVRES:	5 – 8 minutes typical
VECTOR MAGNETOMETER:	Develco Model 9202-02 (3-axis fluxgate)
MICROCOMPUTER:	SBC-11/21 Plus (DEC) Front End LSI-11/73 (DEC) Main CPU
KEYBOARD:	limited alphanumeric
DISPLAY:	green fluorescent, 80 character self scan panel
OUTPUTS:	serial data communication port: RS232C – max. rate 19.2 K Baud parallel output port: 16 bit with full handshaking (DRV11-J) (optional)

APPENDIX C-2

Specifications – RMS Instruments Automatic Aeromagnetic Digital Compensator

POWER: 28 +/- 4 VDC, 5A, 150 W (for single magnetometer) 7A, 196 W (for gradiometer system)

ENVIRONMENTAL:

OPERATING TEMPERATURE: 0 to 50 degrees C

STORAGE TEMPERATURE: -20 to 55 degrees C

RELATIVE HUMIDITY: 0 – 99%, non–condensing

ALTITUDE: 0 – 6000 metres

PHYSICAL DATA:

console dimensions: 483 x 178 x 440 mm
console weight: 12.5 kg
power supply dimensions: 225 x 180 x 220 mm
power supply weight: 5.5 kg

APPENDIX D-1

SPECIFICATIONS – GR900 DETECTOR INTERFACE CONSOLE

PMT Capacity:	A maximum of 12 downward-looking and 3 upward-looking photomultiplier tubes (PMT) may be accommodated.
H. V. Power Supply	Common supply of 1400 V for all PMT anodes with an individual PMT cathode adjustment range from 0 to +400 volts.
Gain Range:	Adjustable over 16/1 range by varying PMT cathode voltage.
Resolution:	The PMT gain can be adjusted and reset to within $\pm 0.2\%$, ie. the resolution of the gain control is ± 0.2 volts.
Output Current:	250 microamps @ 1400 volts max. available for each PMT.
PMT Regulation:	Each PMT voltage is stable to $\pm 0.01\%$.
Operating Temperature:	0° C to +50° C ambient.
Mixer Amplifiers:	Input capability up to 12 PMT's, or 50.4 l downward-looking and 3 PMT's or 12.6 l upward-looking.
Mixer Gain:	Input equals output (gain = 1). With a 95 ohm load. 0.5 volt = 1 MeV. 5.0 volt max output into 95 ohm load.
Temperature Control:	+20°C to +60°C internal DET package temperature in 10°C steps.
Temperature Regulation:	$\pm 1^{\circ}\text{C}$ for ambient temperature range from -20°C to +45°C.
Power Requirements:	Console: ± 15 V, 100 mA Xtal Heater: 28 V, 0.75 amp/Xtal Note: Additional ± 20 mA required for each PMT
Console Size and Weight:	8.9 cm x 48.3 cm x 38 cm deep 7.9 kg

APPENDIX D-2

SPECIFICATIONS – DET1024 SPECTROMETER CRYSTAL DETECTOR

Crystal Type:	NaI – slab form – 10.1 cm thick, 40.6 cm wide and 40.6 cm long
Volume:	16,780 cu cm
System Resolution:	Equal to or less than 10% FWHM at 662 KeV. Held within 0.5% of starting value over 12 hours of continuous operation.
Peak Shift:	Held within +/- 1% over 12 hours of continuous operation. Split window peak setting by front panel meter.
Gain Controls:	Individual controls for each PMT on Detector Interface (see GR-900 Detector Interface specification)
High Voltage Power Supply	1200V DC held within +/- 1% over 24 hours of continuous operation. (Supplied by GR-900)
Temperature:	Operating: Internal temperature automatically regulated to +/- 1°C over the range +10°C to +50°C by the GR-900.
Storage:	-20°C to +65°C
Power:	22 to 32V DC. 20 watts average, 150 watts peak (supplied by GR-900). Provision for separate standby overnight power supply.
Dimensions and Weight:	Crystal Detector package – 18.1 cm x 53.7 cm x 64.1 cm 77.3 kg

APPENDIX D-3

SPECIFICATIONS – NORLAND IT-5410 ANALOG-TO-DIGITAL CONVERTER

A. ADC INPUT

Polarity:	0–10V unipolar or positive first bipolar
Full scale input:	8 volts
Rise time:	0.1 to 10 microseconds
Fall time:	0.1 to 10 microseconds
Impedance:	1000 ohms
Duration:	0.5 microseconds minimum
Coupling:	DC (BLR OFF) or AC (BLR ON)

B. PERFORMANCE

Conversion Clock Rate:

50 MHz (IT-5410/50), 8192 channel resolution

100 MHz (IT-5410/100), 8192 channel resolution

200 MHz (IT-5410/200), 8192 channel resolution

Conversion Time per event:

Signal rise time + 1.2 microseconds + Logic + (Y x N) nSec

where Y = 20 for 50 MHz

10 for 100 MHz

5 for 200 MHz

and N = channel number

ACD Linearity

1. Integral: +/- .075 over upper 99% of full scale range

2. Differential: +/- .075 over upper 99% of full scale range

ACD Stability

Long Term: Less than .01% zero level and conversion gain shift for 24 hour period at constant temperature and line voltage

Temperature: Less than .005% of full scale /C

Peak Shift: Less than 0.04% of full scale for count rates up to 20 kHz

Channel Profile: Typically better than 90%

C. CONTROLS

Baseline Restorer (BLR):

Switchable AC passive.

Coincidence (COINC):

Prompt (delayed jumper selectable).

Zero:

0–100% range control for selecting zero energy intercept level by 22 turn potentiometer.

Lower Level Discriminator (LLD):

10 turn potentiometer control for 0–100% discrimination of lower level input signal.

Upper Level Discriminator (ULD):

22 turn potentiometer control for 5–125% discrimination of upper level input signal.

SPECIFICATIONS – NORLAND IT-5410 ANALOG-TO-DIGITAL CONVERTER

Gain:

Miniature LED indicators activated by momentary toggle switch selects conversion gain setting. Ranges available for 8 volt input

APPENDIX D-4

	signal are: 256, 512, 1024, 2048, 4096, 8192 channels.
Offset:	Function: Offsets spectrum digitally by value indicated on miniature LED. Offsets are toggle selectable in 256 channel increments throughout the 8192 channel range.
Dead Time Meter:	Indicates % of dead time of ADC for converting an input pulse. Range is 0–100%.
SCA:	Single channel analyser output available on ADC rear panel. 50 pin connector and BNC connector and BNC connector on rear panel of IT-5400 mainframe.

D. MECHANICAL

- (1) Single width NIM – standard configuration.
- (2) 50 pin connector on rear panel provides all significant I/O signals.
- (3) Compatible with all NIM standard bins and power supplies per TID-20893 (Rev. 3) which provide = 6V output.

APPENDIX E-1

SPECIFICATIONS - G866 BASE STATION MAGNETOMETER

Display: Six-digit, seven segment, numeric display of magnetic field with 0.1 nT resolution. Same display used to set or view time-of-day and date, signal strength, battery voltage, and variables.

Resolution: Varies from 0.1 to 1 nT depending on sample interval. 1 nT for 0.5 to 0.9 second, 0.5 nT for 1.0 to 1.7 seconds, 0.2 nT for 1.4 to 2.9 seconds, and 0.1 nT for 3.0 or more seconds.

Accuracy: 0.5 nT.

Controls: Pressure-sensitive keyboard to control operation and to select variables. All control clock settings are stored in non-volatile memory, powered by lithium battery.

Clock: Julian clock with stability of 5 seconds per month at room temperature and 5 seconds per day over a temperature range of -20 to +50 degrees Celsius.

Tuning: Push-button tuning from keyboard. Current tuning value displayed on request. Tuning range is from 20,000 to 90,000 nT.

Gradient Tolerance: Tolerates gradients to 5000 nT/metre. When high gradients reduce signal quality, a partial reading is maintained at a resolution consistent with implied accuracy.

Sample Interval: Push-button selection of sample interval from 0.5 to 999.9 seconds. Resolution of 0.1 seconds.

Manual Read: Readings may be initiated by a front panel push-button.

External Cycling: Can be initiated by external cycling device.

Recorder: Electrosensitive recorder producing permanent records insensitive to heat, cold, sunlight or age. Chart width approximately 10 cm with the following formats available.

Narrow: Approximately one half of chart is an analog representation of every reading formed from closely connected dots in two overlapping scales. Remainder of chart is a numerical listing of periodic reading (eg., every ninth reading) and time.

Wide Analog: The printed table may be deleted and the analog scale expanded when a high resolution analog chart is the preferred format (eg., in magnetic search).

Variable "Chart Speed": Simulates changes in chart speed by varying time-axis spaces between plotted readings.

APPENDIX E-2

SPECIFICATIONS - G866 BASE STATION MAGNETOMETER

Recorder Scale: Four, push-button selected scales of 10/100, 20/200, 50/500 or 100/1000 nT full scale. The analog records are dual range, as though there were two overlapping pens recording at different scale factors. The scales overlap by 20% with hysteresis so that there is no jitter at the scale edges.

Event Mark: A front panel push button or external input will cause an extra mark to be added for identification of special events.

Paper Feed: Advances paper rapidly for loading and unloading paper. Also causes the printer to annotate the record with sensitivity, scale factors, sample interval and date.

Special Functions: Internal switch, accessible by hinging up the front panel, allows selection of variations in operation:

- (a) Vary "chart speed" (see recorder).
- (b) Narrow chart (see recorder).
- (c) Wide analog chart (see recorder).
- (d) Power conservation. Display will automatically shut off 7 seconds after a reading has been taken, or two minutes after a key has been depressed.
- (e) 3-point running average (smooths data by taking running average).
- (f) 5-point running average (smooths data by taking running average).
- (g) 7-point running average (smooths data by taking running average).
- (h) Control disable (disable all front panel controls which might be used to modify the stored parameters, prevents operator errors), saves power.

Outputs: (1) BCD character serial output of time, day and field readings for use with external digital recorder. (Also outputs suitable handshaking signals for interfacing.) and (2) RS-232-C compatible ASCII output of time, day, and field reading: followed by a carriage return and line feed at three selectable baud rates (110, 300, 9600). This output is for an external printer or computer-based acquisition system.

APPENDIX F - AIRCRAFT ACQUISITION SYSTEM

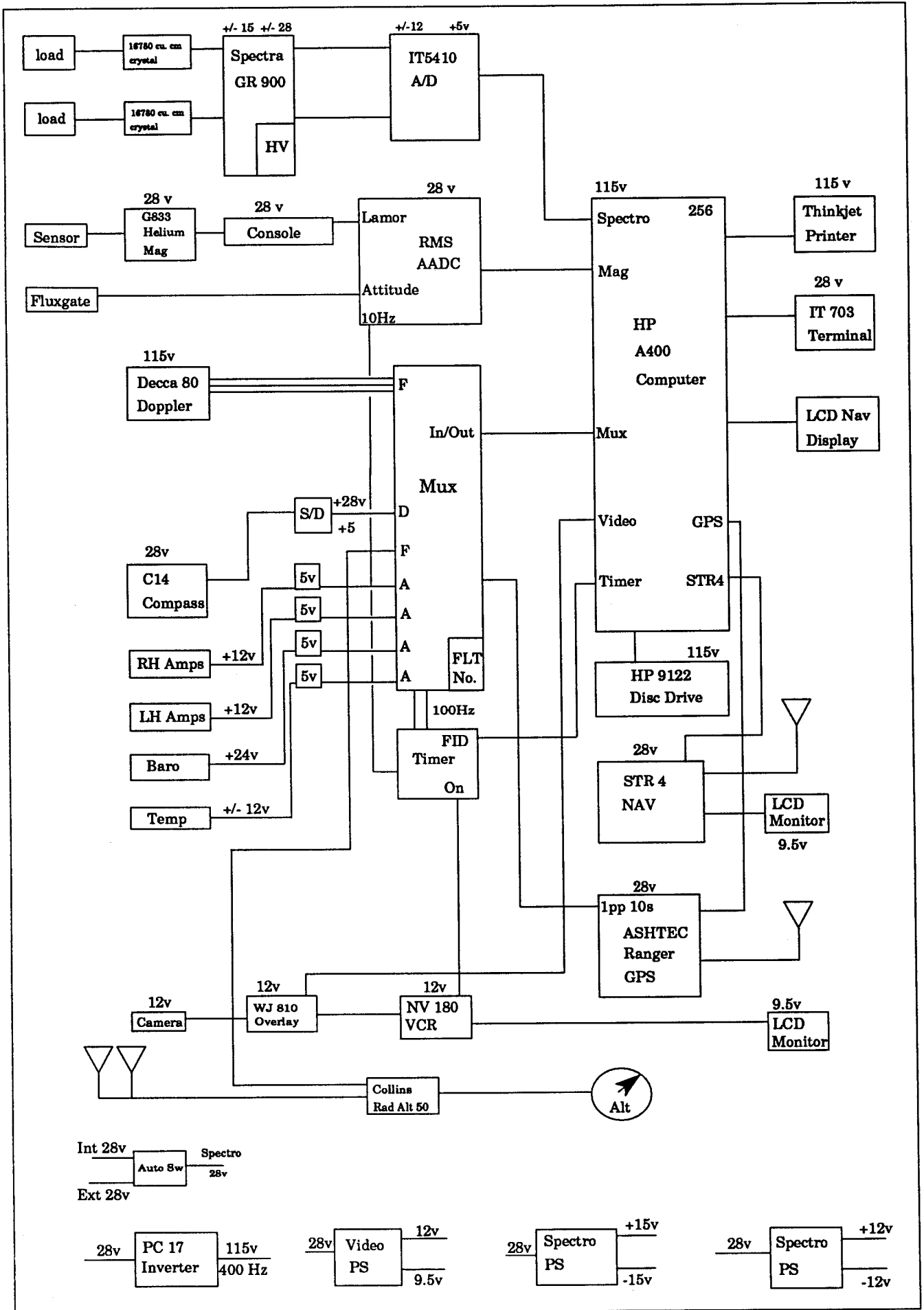

APPENDIX G-1

Compensation Results

- COMPENSATION 1. Date flown: 19 June 1991
 Dates used: 19 June to 3 July 1991
- SDU = 0.4100
SDC = 0.05666
IR = 7.2
VN = 10.9
- COMPENSATION 2. Date flown: 3 July 1991
 Dates used: 3 July – 26 July 1991
- SDU = 0.4366
SDC = 0.05771
IR = 7.6
VN = 10.9
- COMPENSATION 3. Date flown: 26 July 1991
 Dates used: 26 July 1991
- SDU = 0.3905
SDC = 0.05768
IR = 6.7
VN = 11.0
- COMPENSATION 4. Date flown: 27 July 1991
 Dates used: 27 July – 8 August 1991
- SDU = 0.3978
SDC = 0.05823
IR = 6.8
VN = 10.0
- COMPENSATION 5. Date flown: 8 August 1991 (after wing tips fitted)
 Dates used: 8 August – 23 August 1991
- SDU = 0.4255
SDC = 0.05173
IR = 8.2
VN = 10.7

APPENDIX G-2

Compensation Results

COMPENSATION 6. Date flown: 23 August 1991
(after aircraft service and mag components changed)
Dates used: 23 August – 3 September 1991

SDU = 0.5609
SDC = 0.04538
IR = 12.4
VN = 10.9

COMPENSATION 7. Date flown: 3 September 1991
(after mag components changed)
Dates used: 3 September – 10 September 1991

SDU = 0.5340
SDC = 0.04483
IR = 11.9
VN = 10.7

COMPENSATION 8. Date flown: 10 September 1991
(after mag components changed)
Dates used: 10 September – 12 September 1991

SDU = 0.4239
SDC = 0.04268
IR = 9.9
VN = 11.2

COMPENSATION 9. Date flown: 12 September 1991
(after mag components changed)
Dates used: 12 September – 14 September 1991

SDU = 0.4596
SDC = 0.03826
IR = 12.0
VN = 11.2

COMPENSATION 10. Date flown: 14 September 1991
Dates used: 14 September – 25 September 1991

SDU = 0.4489
SDC = 0.03674
IR = 12.2
VN = 11.1

APPENDIX G-3

Compensation Results

COMPENSATION 11. Date flown: 25 September 1991
Dates used: 25 September – 31 October 1991

SDU = 0.3540
SDC = 0.003600
IR = 9.8
VN = 10.5

For all compensations the air conditioner was operating.

SDU = Standard deviation of the data recorded during manoeuvres.

SDC = Standard deviation of the data recorded during manoeuvres after compensation corrections have been applied.

IR = Improvement ratio = SDU / SDC

VN = Vector Norm, a measure of the degree of difficulty in calculating the coefficients.

APPENDIX H

Gamma-ray Spectrometer Test Line Location

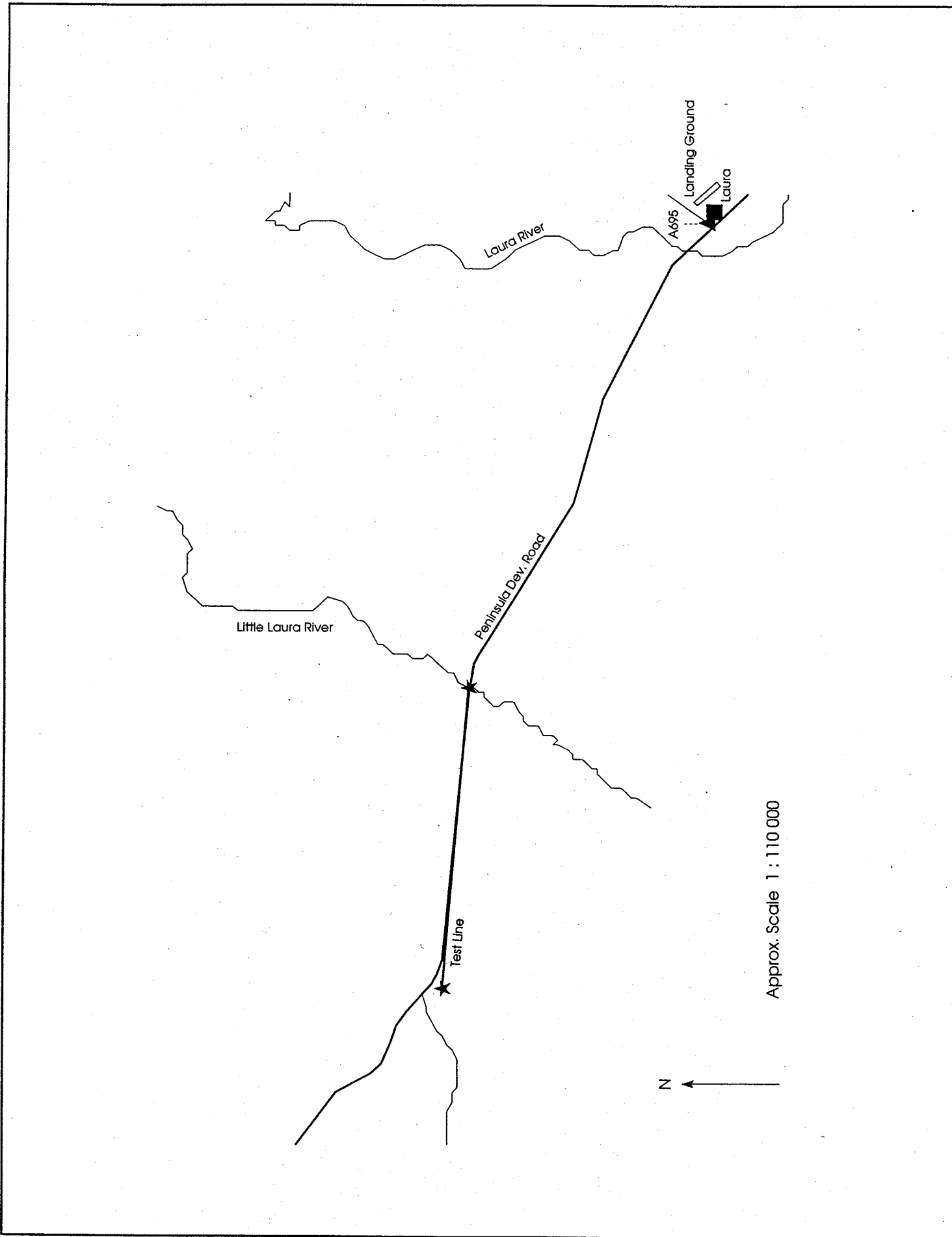

APPENDIX I

The Australian Geodetic Datum

For geophysical surveys the real shape of the earth has to be considered. An ellipsoid of revolution around the earth's north-south axis approximates the earth's shape. This figure is called the spheroid. The mean sea level equipotential surface describing the shape of the earth is known as the geoid.

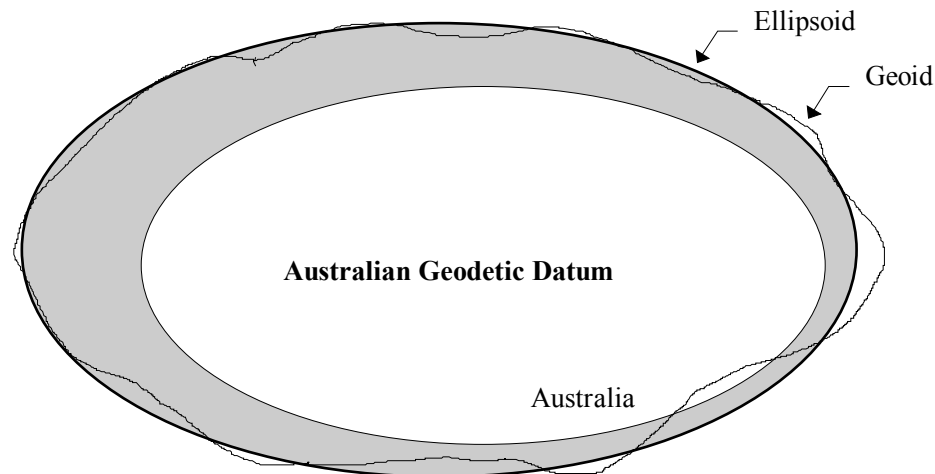

Calculated positions from the GPS are in the World Geodetic System 1984 (WGS84). During processing these positions are converted to the local reference datum, AGD84 or Australian Geodetic Datum 1984.

This non-geocentric datum comprises the Australian National Spheroid (ANS) oriented and located in such a manner as to "best-fit" the geoid over the Australian continent.

The Australian geodetic datum is defined by a semi-major axis (a) and flattening (f) of the selected ellipsoid and the geodetic coordinates of the origin or fundamental station. The origin is referred to as the Johnston Origin. For AGD84:

a	=	6378160 m
f	=	1/298.25
latitude	=	25° 56' 54.5515" S
longitude	=	133° 12' 30.0771" E
height	=	571.2 metres above ellipsoid

For an ideal local datum the geoid-spheroid separation over a region should be small and uniform. At the time of the AGD84 adjustment it was assumed that the geoid and the spheroid coincided at Johnston.

APPENDIX J

Corrections to Differential GPS Navigation Data

(a) Position calculation delay correction

A correction due to the finite time taken for the GPS system to calculate a position and transfer the information to the acquisition system. A delay of 0.6 seconds has been determined for calculations using up to eight satellites by flying clover leaf patterns over a reference point. This value is considered to be representative and was used for all delay corrections.

(b) Fiducial synchronisation correction

A correction due to the time lag between when a GPS position is available to the acquisition system and when the next fiducial is available to pair the position with.

(c) "Ranger" corrections

Using the range data which are recorded internally on both GPS receivers every five seconds, "Ranger" calculates the correct positions at five second intervals along the flight path. These corrected positions are utilised when correcting the aircraft raw position data which are recorded every second.

Discontinuities (steps) sometimes occur in raw GPS data. These are also manifested as steps in the correction set.

When such steps in the raw GPS data occur between successive correction values, the corrections are linearly interpolated to the step boundary using corrections from the appropriate side of the step.

If multiple steps in the raw GPS data occur between successive correction values it is impossible to interpolate corrections over this interval, in which case the intervening GPS data are set to undefined.

(d) Low pass filter

The problem described in (c) can lead to small steps in the data where the original steps were too small to detect so were not corrected. A low pass 11 point convolution filter with a cut-off wavelength of 300 metres was passed over the data.

(e) Coordinate system conversion

GPS data were converted from the WGS 84 geodetic coordinate system to the AGD 84 geodetic coordinate system.

(f) Reference navigation data to position of magnetometer sensor

The calculated GPS positions refer to the position of the GPS receiver's antenna. Since the magnetometer is the most position sensitive instrument, all position data is shifted 11.4 meters toward the rear of the aircraft to correspond with the position of the magnetometer's sensor.

(g) Doppler infill of gaps

Whenever gaps less than ten kilometres in length occurred in the GPS longitude and latitude data they were infilled with data generated from the doppler navigation system. Gaps in the GPS data greater than ten kilometres were reflowed.

APPENDIX K

LOCATION OF SUB-AREAS WITH EXTRA MICRO-LEVELLING APPLIED

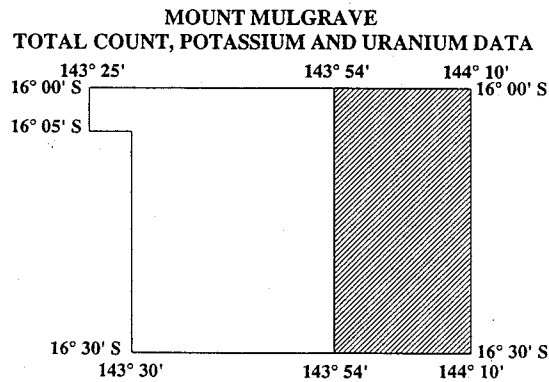
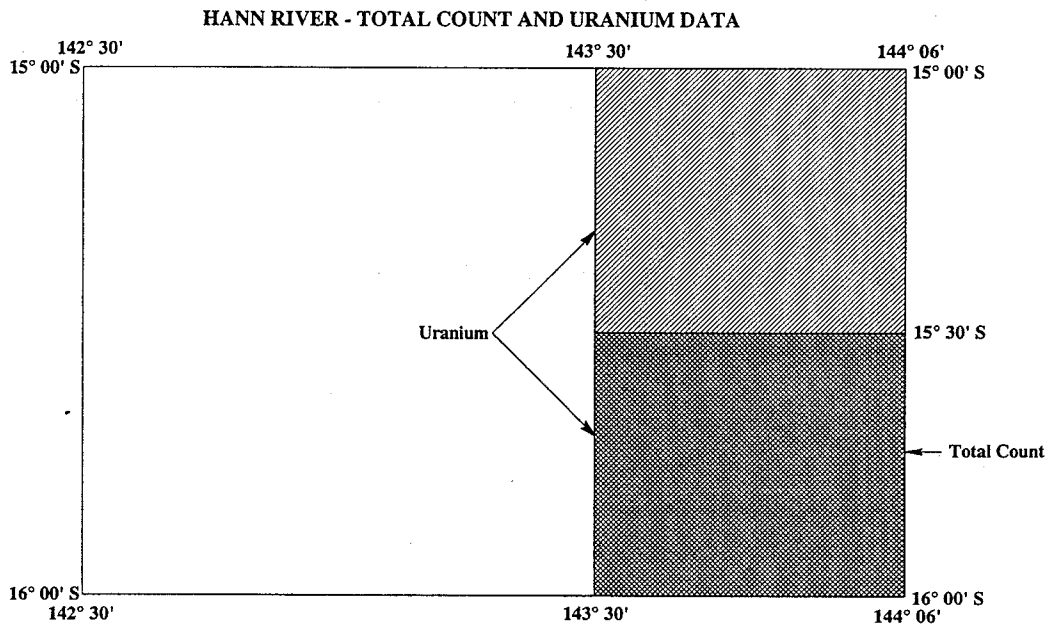
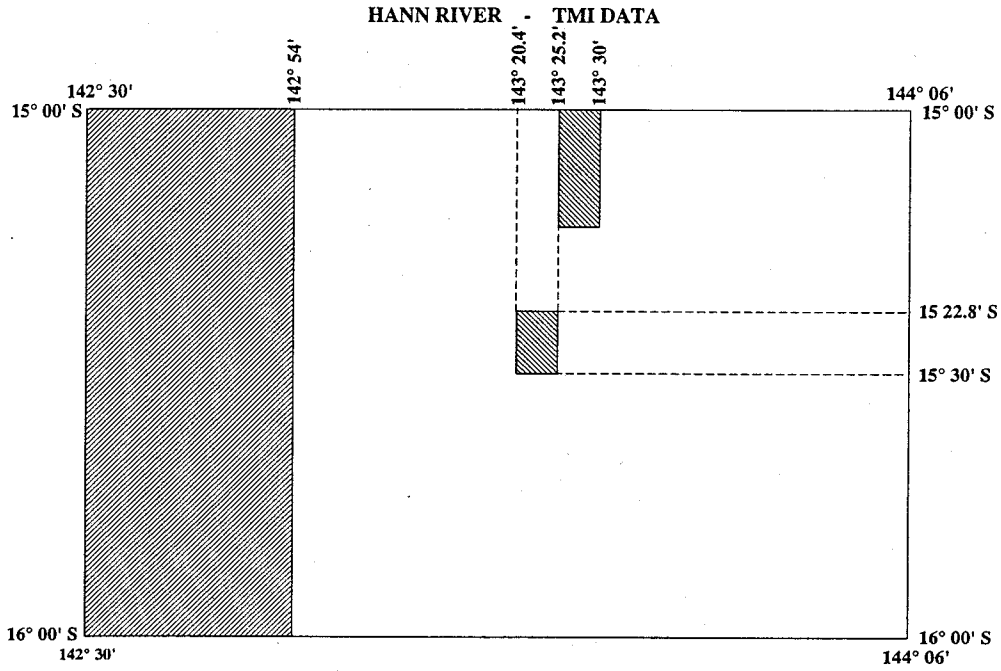

APPENDIX L-1

Geophysical Maps

Name	Type	Contour Interval/ Vertical Scale	Reference Number
HANN RIVER SURVEY AREA			
1:250 000 scale			
Hann River	TMI Contours	5 nT	22-1/D54-16/1
"	TC Contours	250 cps	22-1/D54-16/2
"	Flight Path		22-1/D54-16/3
1:100 000 scale			
Crosbie Creek	TMI Contours	2 nT	22-2/D54-16/1-1
"	TC Contours	50 cps	22-2/D54-16/2-1
"	Flight Path		22-2/D54-16/3-1
"	TMI Profiles	150 nT/cm	22-2/D54-16/4-1
Dixie	TMI Contours	2 nT	22-2/D54-16/1-2
"	TC Contours	100 cps	22-2/D54-16/2-2
"	Flight Path		22-2/D54-16/3-2
"	TMI Profiles	150 nT/cm	22-2/D54-16/4-2
Kalinga	TMI Contours	2 nT	22-2/D54-16/1-3
"	TC Contours	50 cps	22-2/D54-16/2-3
"	Flight Path		22-2/D54-16/3-3
"	TMI Profiles	50 nT/cm	22-2/D54-16/4-3
Peters Lagoon	TMI Contours	2 nT	22-2/D54-16/1-4
"	TC Contours	50 cps	22-2/D54-16/2-4
"	Flight Path		22-2/D54-16/3-4
"	TMI Profiles	25 nT/cm	22-2/D54-16/4-4
Strathleven	TMI Contours	2 nT	22-2/D54-16/1-5
"	TC Contours	50 cps	22-2/D54-16/2-5
"	Flight Path		22-2/D54-16/3-5
"	TMI Profiles	50 nT/cm	22-2/D54-16/4-5
Jedda Creek	TMI Contours	2 nT	22-2/D54-16/1-6
"	TC Contours	100 cps	22-2/D54-16/2-6
"	Flight Path		22-2/D54-16/3-6
"	TMI Profiles	125 nT/cm	22-2/D54-16/4-6

APPENDIX K

LOCATION OF SUB-AREAS WITH EXTRA MICRO-LEVELLING APPLIED

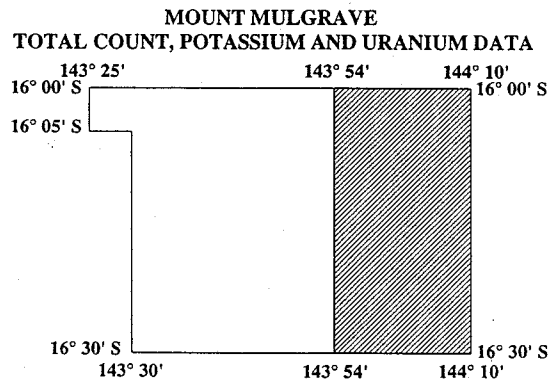
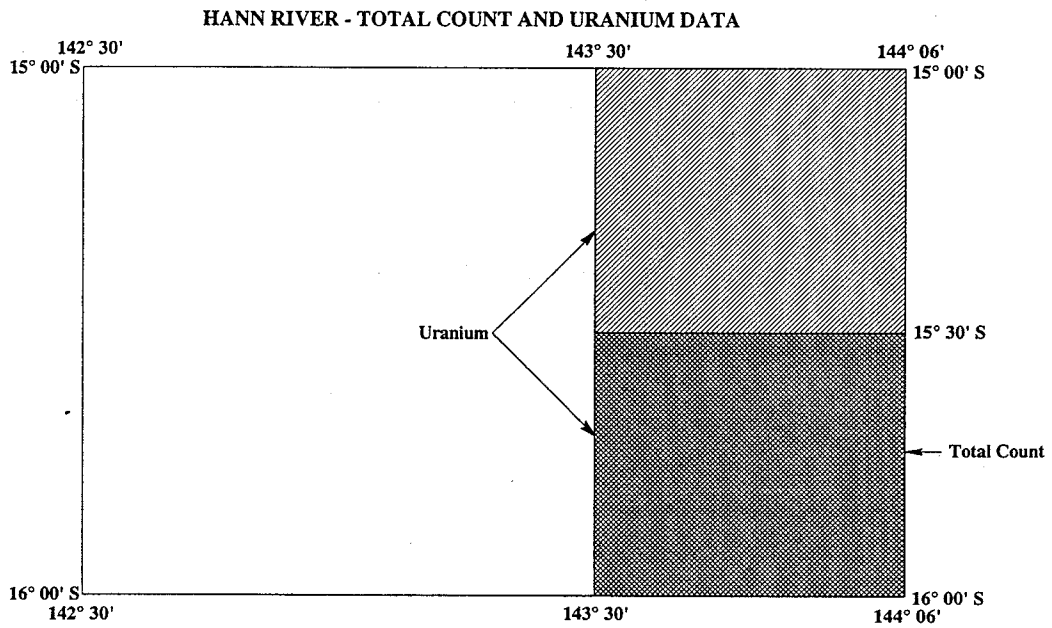
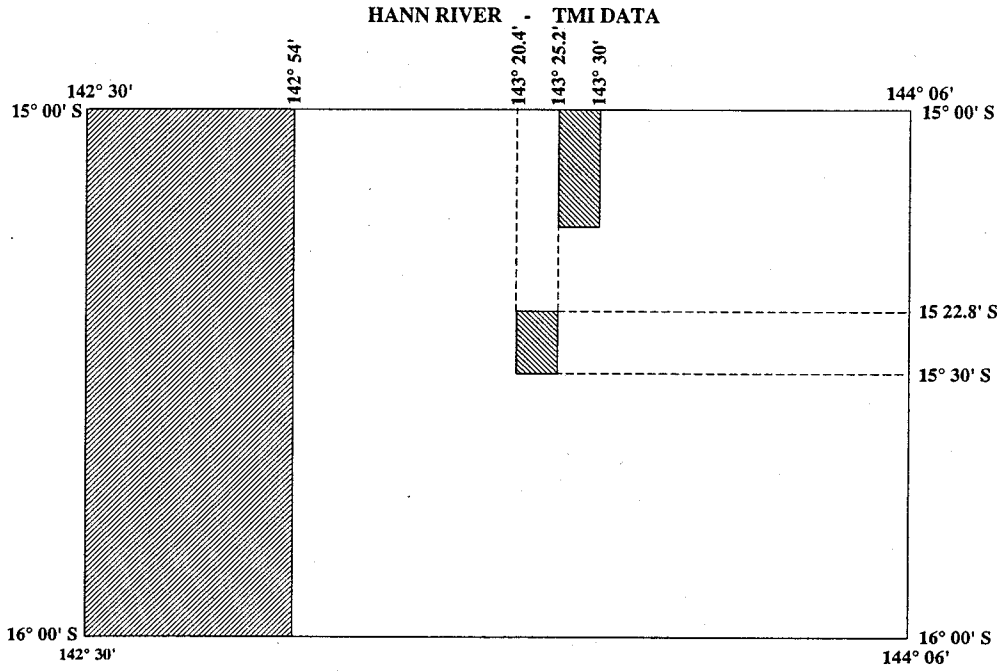

APPENDIX L-2

Geophysical Maps

Name	Type	Contour Interval/ Vertical Scale	Reference Number
------	------	-------------------------------------	---------------------

MOUNT MULGRAVE SURVEY AREA

1:100 000

Mt. Mulgrave	TMI Contours	2 nT	22-2/E54-04/1-3
"	TC Contours	100 cps	22-2/E54-04/2-3
"	Flight Path		22-2/E54-04/3-3
"	TMI Profiles	125 nT/cm	22-2/E54-04/4-3
Maytown	TMI Contours	2 nT	22-2/E55-01/1-1
"	TC Contours	100 cps	22-2/E55-01/2-1
"	Flight Path		22-2/E55-01/3-1
"	TMI Profiles	150 nT/cm	22-2/E55-01/4-1

APPENDIX M-1

AGSO ARCHIVE DATA, GRID AND MAGNETIC TAPE FORMAT FOR AIRBORNE GEOPHYSICAL DATA

CONTENTS

1. THE AGSO SEQUENTIAL FILE STRUCTURE
 - 1.1 INTRODUCTION
 - 1.2 GENERAL FILE STRUCTURE
 - 1.3 CHANNELS AND SAMPLES
 - 1.4 SEGMENT DIRECTORY RECORD
 - 1.5 DATA RECORD
 - 1.6 NO DATA VALUE
 - 1.7 STANDARD DATA CHANNELS

2. PHYSICAL FORMAT FOR MAGNETIC TAPES
 - 2.1 GENERAL
 - 2.2 PHYSICAL PARAMETERS OF TAPE
 - 2.3 TAPE STRUCTURE
 - 2.4 PHYSICAL RECORDS AND BLOCKS

3. GRID FILE FORMAT
 - 3.1 HEADER RECORD
 - 3.2 DATA RECORDS

TABLES

FIGURES

APPENDIX M-2

AGSO ARCHIVE DATA, GRID AND MAGNETIC TAPE FORMAT FOR AIRBORNE GEOPHYSICAL DATA

1. THE AGSO SEQUENTIAL FILE STRUCTURE

1.1 INTRODUCTION

This appendix describes the general sequential file structure used by AGSO to store airborne geophysical data. For the purpose of this survey ten data chains are involved for each line and tie. They are:

- channel 4 edition 1 (processed navigation)
- channel 4 edition 2 (processed magnetics)
- channel 4 edition 3 (processed gamma-ray spectrometrics)
- channel 4 edition 4 (processed digital elevation model)
- channel 5 edition 1 (doppler)
- channel 6 edition 1 (raw gamma-ray spectrometrics)
- channel 8 edition 1 (raw magnetics)
- channel 10 edition 1 (multi-channel spectra)
- channel 14 edition 1 (pressure,temperature,cosmic data)
- channel 16 edition 1 (raw navigation)

1.2 GENERAL FILE STRUCTURE

The information pertaining to each traverse (line or tie) is held on the file as a separate entity called a segment. Segments are separated from each other by industry standard EOF records. The end of the file is indicated by two or more consecutive EOF records. Each segment consists of two types of records. Both types are 5120 characters long.

1. Segment Directory Record (SDR) : the first record on each segment. It defines the data content of the segment.
2. Data Records (DAR's) : hold the measured data values. The general structure is shown in Figure 1.

1.3 CHANNELS AND SAMPLES

Data are recorded at regular intervals in time along a traverse. The data recorded at one instant of time are held as any ordered set or sub-set. Each set is held logically distinct and referred to as a channel. The data records in a segment hold all the information for one channel in the form of a data chain, then all the data for the next channel and so on for as many channels as the segment holds.

Each channel is uniquely defined by a channel number and an edition number. The measurement(s) taken for a channel at a given time is called a sample. Samples are held within each channel in increasing order of fiducial (time).

In defining channels the channel number can be used to define the sample format and the edition type of the data. For example, within AGSO, samples with format (longitude, latitude,

APPENDIX M-3

AGSO ARCHIVE DATA, GRID AND MAGNETIC TAPE FORMAT FOR AIRBORNE GEOPHYSICAL DATA

value, value...) have a channel number of 4 with edition 2 for magnetics and edition 3 for radiometrics.

1.4 SEGMENT DIRECTORY RECORD (SDR)

Lines and ties are uniquely identified as follows :

1. Project number: a unique number to identify the survey.
2. Group number : a unique number within a survey for each flight made. That is, several lines may be recorded on one flight (group). AGSO convention is for group numbers to lie between 001 and 999 inclusive.
3. Segment numbers : a unique number within a survey for a line or tie. AGSO convention is for ordinary line numbers to lie between 1000 and 9999 inclusive and tie line numbers between 100 and 999 inclusive.

The segment directory record identifies the data segment at Project, Group and Segment level and defines the data channels, their structure and the location of their data chains in the segment. Each SDR consists of one or more 10 word blocks. The first, the Segment Identification Block (SIB), identifies the segment and gives the number of data channels held in the segment.

For this survey the number of data channels is nine as mentioned in the introduction. Subsequent blocks, one for each data channel, define the data channels and their location within the segment. These are called Channel Identification Blocks (CIB's). A typical SDR is shown in Figure 1 and its exact format given in Table 1. All unused words in the SDR are set to zero.

The last word in the record in the past has been used as check sum and represents the sum of all the other words in the record. The check sum word is no longer used and is set to zero.

The overall record format is 2I9, 509I10, I12.

1.5 DATA RECORD (DAR)

These each contain 512 values. The first two are fiducials giving the fiducial range of the samples contained in the record. The next 508 represent data values, the second last is always zero (to maintain compatibility with our random access file format) and the last is a record check sum representing the sum of all other values in the record.

If a record is the last one in a data chain for a given channel all unused values are set to zero, with the next channel commencing at the start of the next data record. The N data records in a segment are numbered from 2 to N+1, the SDR being regarded as record one in a segment, with records for a given channel following each other sequentially. The data record addresses in the channel identification block of the SDR refer to this sequential numbering of

APPENDIX M-4

AGSO ARCHIVE DATA, GRID AND MAGNETIC TAPE FORMAT FOR AIRBORNE GEOPHYSICAL DATA

the data records. A typical segment is shown in Figure 1 and the exact format of a data record given in Table 2.

The overall format of each data record is : 2I9, 509I10, I12.

1.6 NO DATA VALUE

For a variety of reasons it is sometimes necessary to flag a data value to indicate it is to be ignored. This is achieved by replacing the data word in question by the value 536870912. If a gap exists in a data chain each word of every sample involved must be replaced by 536870912, the so-called missing value. Thus a 1:1 correspondence is maintained between the fiducials encompassed by a data chain and its samples.

1.7 STANDARD DATA CHANNELS

The standard AGSO data channels are :

- channel 4 edition 1 (processed navigation)
- channel 4 edition 2 (processed magnetics)
- channel 4 edition 3 (processed gamma-ray spectrometrics)
- channel 4 edition 4 (processed digital elevation model)
- channel 5 edition 1 (doppler)
- channel 6 edition 1 (raw gamma-ray spectrometrics)
- channel 8 edition 1 (raw magnetics)
- channel 10 edition 1 (multi-channel spectra)
- channel 14 edition 1 (pressure,temperature,cosmic data)
- channel 16 edition 1 (raw navigation)

C4 E1 - Navigation

Channel number = 4

Edition number = 1

Sample size = 2 words

word 1 = Longitude in degrees * 1 000 000

word 2 = Latitude in degrees * 1 000 000

APPENDIX M-5

AGSO ARCHIVE DATA, GRID AND MAGNETIC TAPE FORMAT FOR AIRBORNE GEOPHYSICAL DATA

C4 E2 - Corrected Total Magnetic Intensity

Channel number = 4

Edition number = 2

Sample size = 4 words

word 1 and word 2 as for C4 E1

word 3 = final (non micro-levelled) TMI (nT) * 1000

word 4 = final micro-levelled TMI (nT) * 1000

C4 E3 - Corrected gamma-ray spectrometer Data

Channel number = 4

Edition number = 3

Sample size = 7 words

word 1 and word 2 as for C4 E1

word 3 = final Total Count (counts/sec) * 1000

word 4 = final Potassium (counts/sec) * 1000

word 5 = final Uranium (counts/sec) * 1000

word 6 = final Thorium (counts/sec) * 1000

word 7 = Altitude in metres above ground level

C4 E4 - Corrected Digital Elevation Model Data

Channel number = 4

Edition number = 2

Sample size = 4 words

word 1 and word 2 as for C4 E1

word 3 = Aircraft Elevation (metres above sea level) * 1000

word 4 = final Terrain Elevation (metres above sea level) * 1000

C5 E1 - Doppler navigation data

Channel number = 5

Edition number = 1

Sample size = 2 words

word 1 = doppler along track (km)

word 2 = doppler across track (m)

APPENDIX M-6

AGSO ARCHIVE DATA, GRID AND MAGNETIC TAPE FORMAT FOR AIRBORNE GEOPHYSICAL DATA

C6 E1 - Raw gamma-ray spectrometer data.

Channel number = 6

Edition number = 1

Sample size = 5 words

word 1 = Total count (counts/sec) * 1000

word 2 = Potassium (counts/sec) * 1000

word 3 = Uranium (counts/sec) * 1000

word 4 = Thorium (counts/sec) * 1000

word 5 = Altitude in metres above ground level

C8 E1 - Raw Magnetics

Channel number = 8

Edition number = 1

Sample size = 1 word

word 1 = TMI * 1000

C10 E1 - Multi-channel spectra

Channel number = 10

Edition number = 1

Sample size = 290 words

word 1 = start fiducial for spectra

word 2 = integration time for spectra (seconds)

word 3 - 34 = define energy range of spectra, fiducials etc.

Some control words yet to be defined.

word 35 = counts in channel 0 (* 1000)

word 36 = counts in channel 1 (* 1000)

word 290 = counts in channel 255 (* 1000)

C14 E1 - Pressure and Temperature

Channel number = 14

Edition number = 1

Sample size = 7 words

word 1 = pressure in millibars * 10

word 2 = temperature in degrees celsius * 10

word 3 - 6 = no longer used

word 7 = cosmic channel (counts) * 1000

APPENDIX M-7

AGSO ARCHIVE DATA, GRID AND MAGNETIC TAPE FORMAT FOR AIRBORNE GEOPHYSICAL DATA

C16 E1 - Raw GPS data

Channel number = 16

Edition number = 1

Sample size = 4 words

word 1 = Longitude in degrees * 1 000 000

word 2 = Latitude in degrees * 1 000 000

word 3 = GPS time in seconds * 1000.

GPS time is recorded in seconds from midnight the previous Sunday

word 4 = Lag time. Time difference between time when a position is calculated and time until the next fiducial is generated by the data acquisition system. (hundredths of a second)

2. PHYSICAL FORMAT FOR MAGNETIC TAPES

2.1 GENERAL

Each magnetic tape (MT) consists of a sequence of segments each segment consisting of one or more physical records. Segments are to be separated by one EOF markers. The end of all information on a tape must be flagged by two or more consecutive EOF markers. Industry standard EOF records apply. Records are to be fixed length and each block is to contain one record.

2.2 PHYSICAL PARAMETERS OF TAPES

- a. Tapes are 12.7 mm (0.5 inch) wide, 9 track industry standard magnetic tapes.
- b. Each tape has an external label identifying the airborne survey, character code, recording density, date tape written and the reel number in the set.

2.3 TAPE STRUCTURE

- a. 9 track
- b. Written in ASCII
- c. Recording density of 6250 bpi
- d. International Standards Organisation end-of-block markers (EOB)
- e. International Standards Organisation end-of-file markers (EOF)
- f. No multi-tape files
- g. Multi-file tapes can be expected. Files will not span tapes.
- h. Last file on each tape shall end with at least two EOF's.

APPENDIX M-8

AGSO ARCHIVE DATA, GRID AND MAGNETIC TAPE FORMAT FOR AIRBORNE GEOPHYSICAL DATA

2.4 PHYSICAL RECORDS AND BLOCKS

- a. Fixed length records of 5120 characters
- b. One record per block

3. GRID FILE FORMAT

3.1 HEADER RECORD

The first record on the file defines the content of the grid, including:

- a. Origin in latitude and longitude.
- b. Grid cell size.
- c. Number of rows and columns in the grid.
- d. Storage mode, i.e. whether the data is stored row by row or column by column. In general the data is stored by row.
- e. The exact header record format is in Table 3.

3.2 DATA RECORDS

Each data record contains 320 values in E16.10 format. No location data is held in the data records - the location of a grid point is determined by its sequence within the file. The data for the grid may be sequenced in row or column order (i.e. row by row or column by column respectively). Each row or column is written on consecutive records and begins at the start of a new record. If the rows/columns do not contain a multiple of 320 values the last record for each row/column is padded with zeros. Any point in the grid which is undefined is set to -9999.0.

In ROW mode, rows are sequenced from north to south and within each row values are ordered from west to east.

In COLUMN mode, columns are sequenced from west to east and within each column values are ordered from north to south.

APPENDIX M-9

AGSO ARCHIVE DATA, GRID AND MAGNETIC TAPE FORMAT FOR AIRBORNE GEOPHYSICAL DATA

TABLE 1

SEGMENT DIRECTORY RECORD FORMAT

1. SEGMENT IDENTIFICATION BLOCK

WORD	CONTENT AND USE	FORMAT
1	PROJECT IDENTIFICATION	I9
2	GROUP IDENTIFICATION	I9
3	SEGMENT IDENTIFICATION	I10
4	NUMBER OF CHANNELS ON SEGMENT	I10
5	DATE CODE - YYMMDD	I10
6	FIDUCIAL FACTOR - (fiducial size in seconds)	I10
7	TIME OF DAY AT FIDUCIAL ZERO IN SECONDS	I10
8	BEARING IN DEGREES (0-359) MEASURED EAST OF NORTH	I10
9	ALTITUDE IN METRES ABOVE SEA LEVEL	I10
10	GROUND CLEARANCE IN METRES	I10

2. CHANNEL IDENTIFICATION BLOCK (for the Nth channel)

WORD	CONTENT AND USE	FORMAT
1	CHANNEL CODE	I10
2	EDITION NUMBERS	I10
3	FIDUCIAL INTERVAL BETWEEN SAMPLES	I10
4	NUMBER OF DATA VALUES (WORDS) PER SAMPLE	I10
5	ADDRESS OF FIRST DATA RECORD FOR CHANNEL	I10
6	ADDRESS OF LAST SAMPLE IN DATA CHAIN	I10
7	FIDUCIAL OF FIRST SAMPLE IN DATA CHAIN	I10
8	FIDUCIAL OF LAST SAMPLE IN DATA CHAIN	I10
9	UNUSED - SET TO ZERO	I10
10	UNUSED - SET TO ZERO	I10

APPENDIX M-10

AGSO ARCHIVE DATA, GRID AND MAGNETIC TAPE FORMAT
FOR AIRBORNE GEOPHYSICAL DATA

TABLE 2

DATA RECORD FORMAT

WORD	CONTENT AND USE	FORMAT
1	FIDUCIAL AT FIRST DATA SAMPLE IN RECORD	I9
2	FIDUCIAL AT LAST DATA SAMPLE IN RECORD	I9
3	FIRST WORD OF FIRST SAMPLE	I10
4	SECOND WORD OF FIRST SAMPLE	I10
	FIRST WORD OF SECOND SAMPLE	I10
	SECOND WORD OF SECOND SAMPLE	I10
	ETC	
511	ALWAYS UNUSED - SET TO ZERO	I10
512	ALWAYS UNUSED - SET TO ZERO	I12

- NOTE:
1. A data sample can be of any length greater than zero.
 2. Each record contains an integral number of samples. This may lead to several unused words at the end of the record which are set to zero.

i.e. If a sample is 7 words long 72 samples will fit in a data record and words 507-510 will be set to zero.

APPENDIX M-11

AGSO ARCHIVE DATA, GRID AND MAGNETIC TAPE FORMAT
FOR AIRBORNE GEOPHYSICAL DATA

TABLE 3

GRID HEADER RECORD FORMAT

CHARACTER POSITION	FIELD LENGTH	FORTRAN FORMAT	CONTENT
1-60	60	6A10	Grid Identification
61-170	10	11A10	Facts defining data acquisition/processing
171-180	10	A10	x,y units defining grid, Usually degrees.
181-192	12	E12.6	x origin of surface. Bottom left hand corner.
193-204	12	E12.6	y origin of surface. Bottom left hand corner.
205-214	10	A10	Type of z data in grid (e.g. TMI).
215-216	2	A2	Blanks.
217-228	12	I12	Number of data records per column or row.
229-240	12	E12.6	Grid increment in the x direction
241-252	12	E12.6	Grid increment in the y direction
253-262	10	A10	Time when original surface created (hh.mm.ss).
263-286	24	2A10,A4	Filter used on original z data.
287-310	12	2E12.6	x,y co-ordinate of the bottom left hand corner of the grid. Same as x,y origin.
311-320	10	A10	Date of creation of surface (dd/mm/yy).
321-344	24	2A10,A4	Blanks.
345-368	12	2E12.6	x,y co-ordinate of top right hand corner of grid. NOTE: these values are too large by one grid increment for tapes created prior to 01/06/85.
369-373	4	I5	Number of rows in the grid.
374-378	5	I5	Number of columns in the grid.
379-382	4	A4	Blanks.
383-388	6	A6	Defines if the grid is stored in column mode (COLUMN) or row mode (ROW).
389-5120			Blank filled.